



MMD Brake Pressure Switch

Service Category Service Department

Section Function Group 364

Technician Skill Level A

Market North America

Applicability

Mack

Model Years	Models
2024	MD6, MD7

Introduction

Mack trucks has determined that certain 2024 model year MD6 and MD7 trucks were built with incorrect Park Brake air pressure sensor. Please follow the instructions below to replace the Park Brake air pressure sensor.

Production Change Information

This bulletin applies to vehicles built within the specified production changes below.

Brand	Engine	Emission Level	Starting Build Date	Ending Build Date
Mack	CU7	EM-USA21	09-November-2023	29-November-2023

Warranty Information

This repair is covered by an authorized Service Program. Reimbursement is obtained through the normal claim handling process.		
Claim Type (used only when uploading from the Dealer Bus. Sys.)		B
Main Labor Code	Description	Hours
3646-03-02-59	Pressure Switch, Park Brake, Replacement	0.8
Causal Part	20489116	
SCC Authorization Code	S3878	
Expiration Date	January 31, 2025	

MMD Brake Pressure Switch

Parts Information

Part Numbers	Part Names	Quantity
20489116	Switch	1



*The **incorrect** part has a yellow stripe on it.



*The **correct** part has no yellow stripe on it.

Calibration Information

N/A

Repair Procedure

Please refer to Impact procedure **3646-03-02-59 Pressure Switch, Park brake, Replacement**

1. Park the vehicle on level surface.
2. Apply the parking brake.
3. Place the gear level in neutral.
4. Install the wheel chocks.

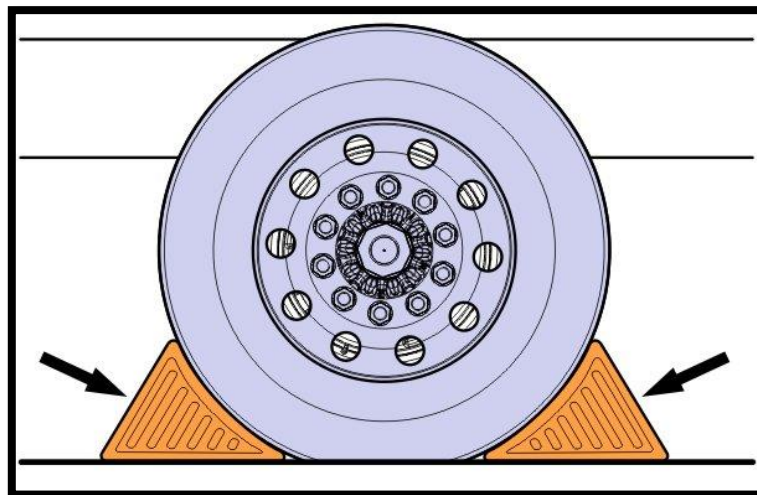

5. Disconnect the cable from the negative terminal.

MMD Brake Pressure Switch

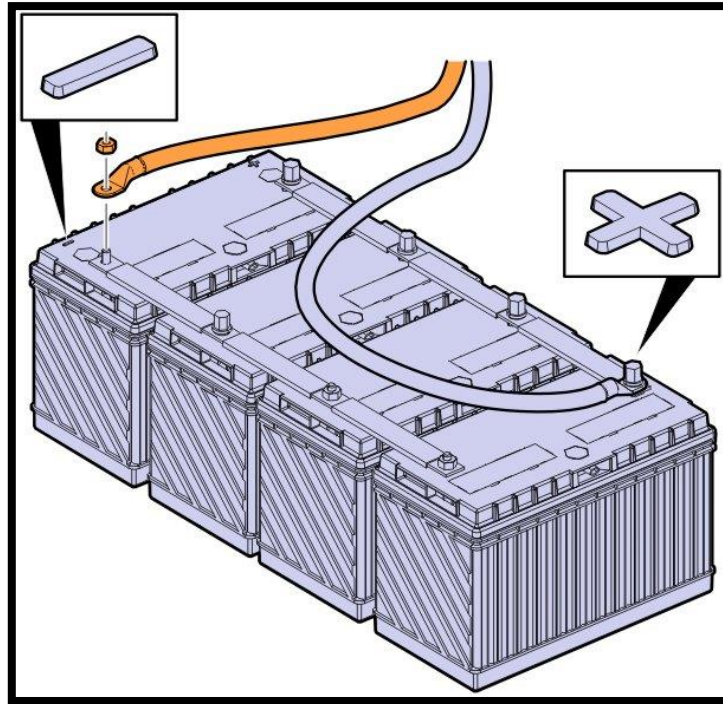

6. Drain the compressed air tanks.

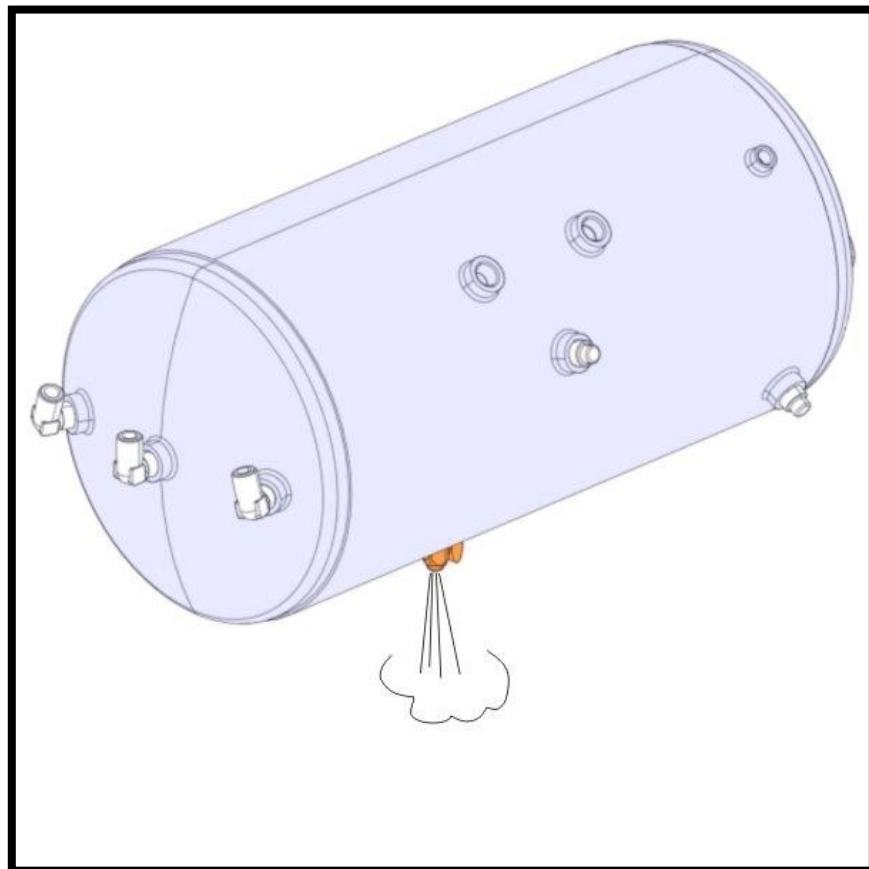

7. Remove the screws.

MMD Brake Pressure Switch

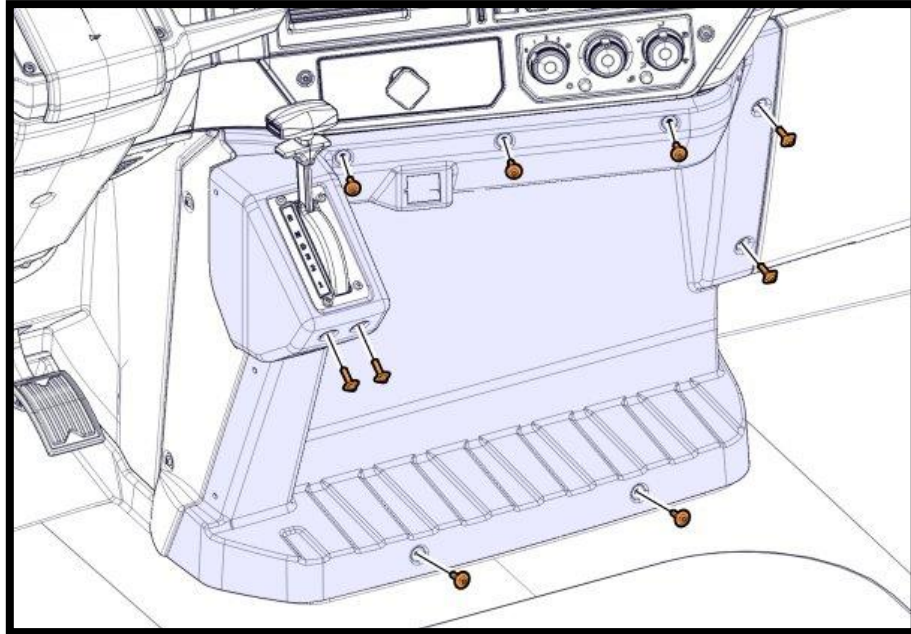

8. Remove the panel.

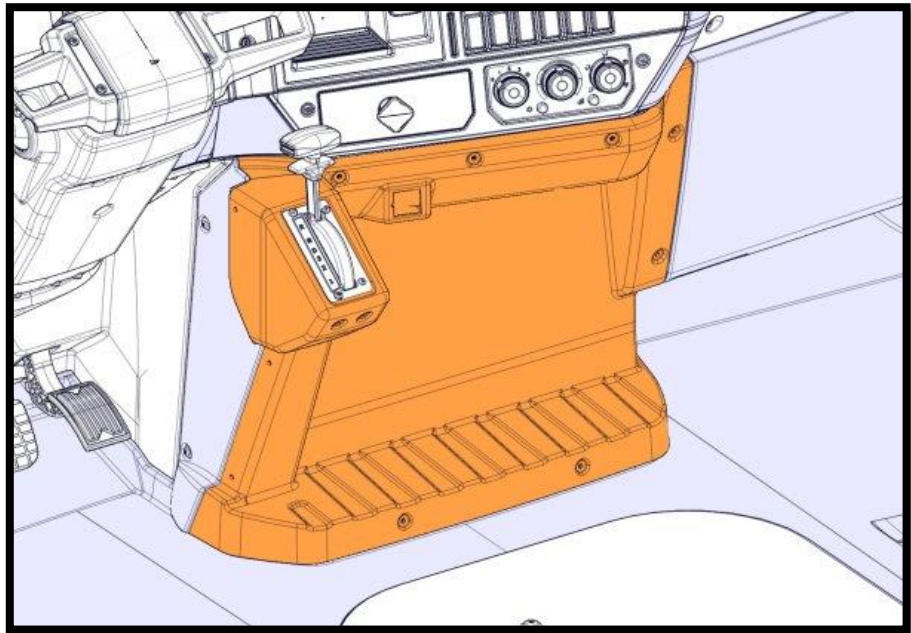

9. Remove the screws.

MMD Brake Pressure Switch

10. Remove the front panel cover.

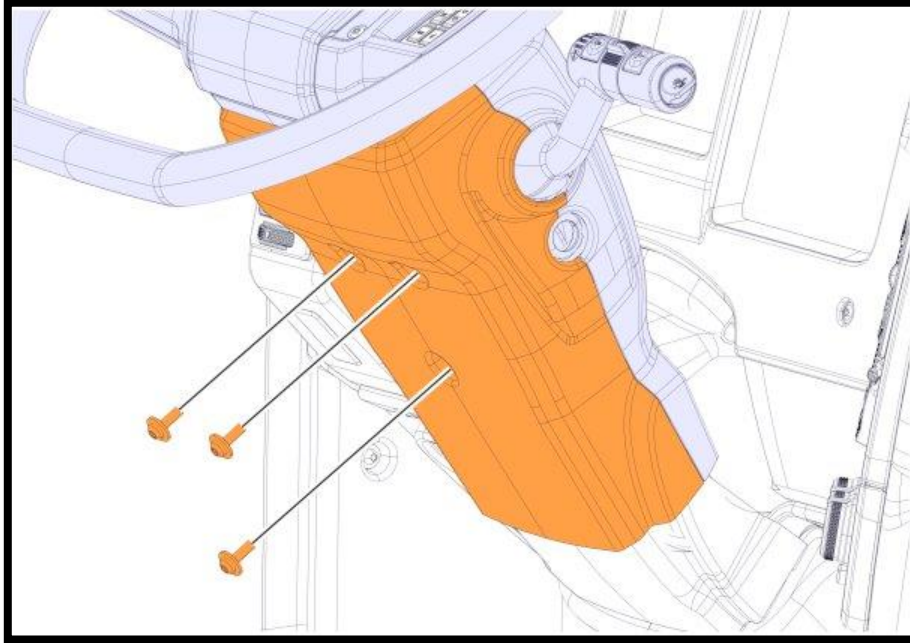

11. Remove the screws.

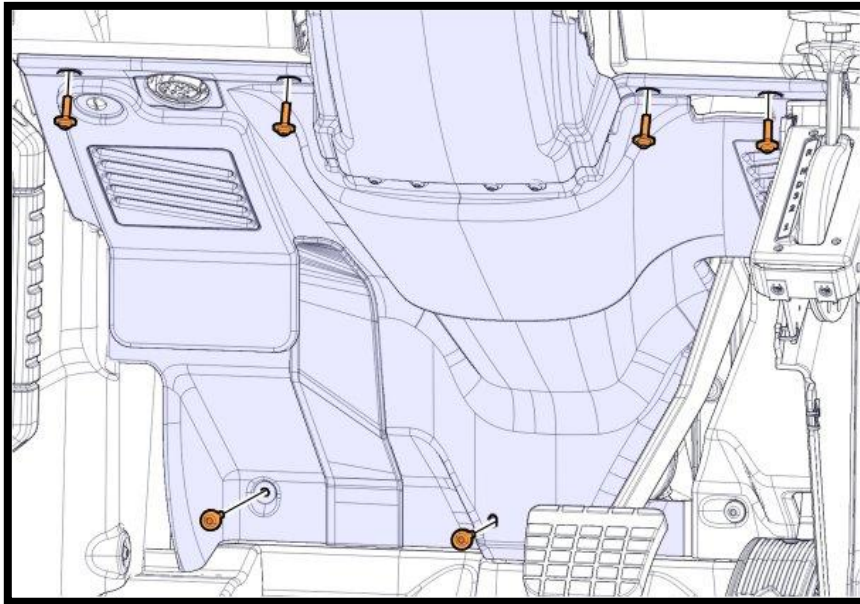

MMD Brake Pressure Switch

12. Remove the panel.

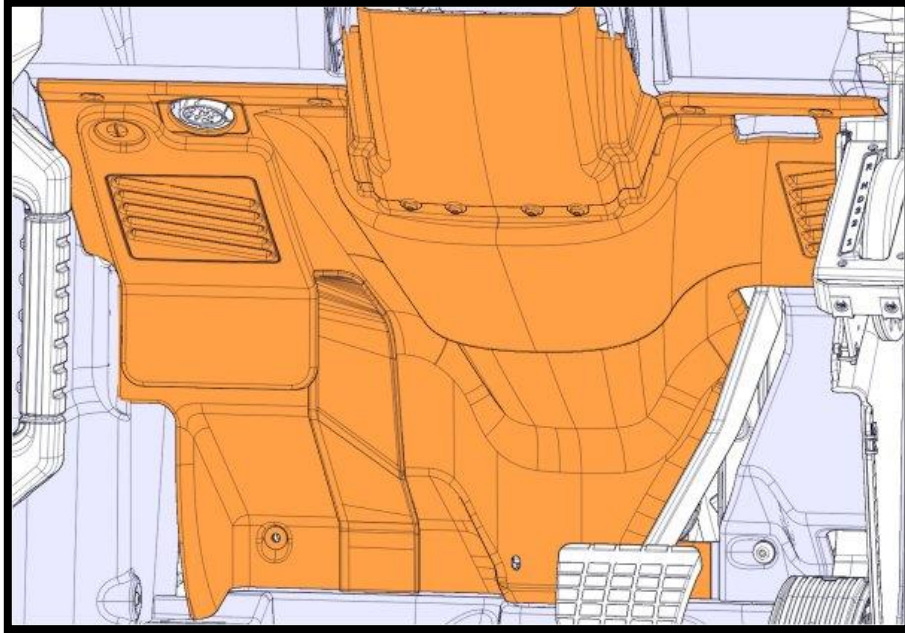

13. Remove the screws.

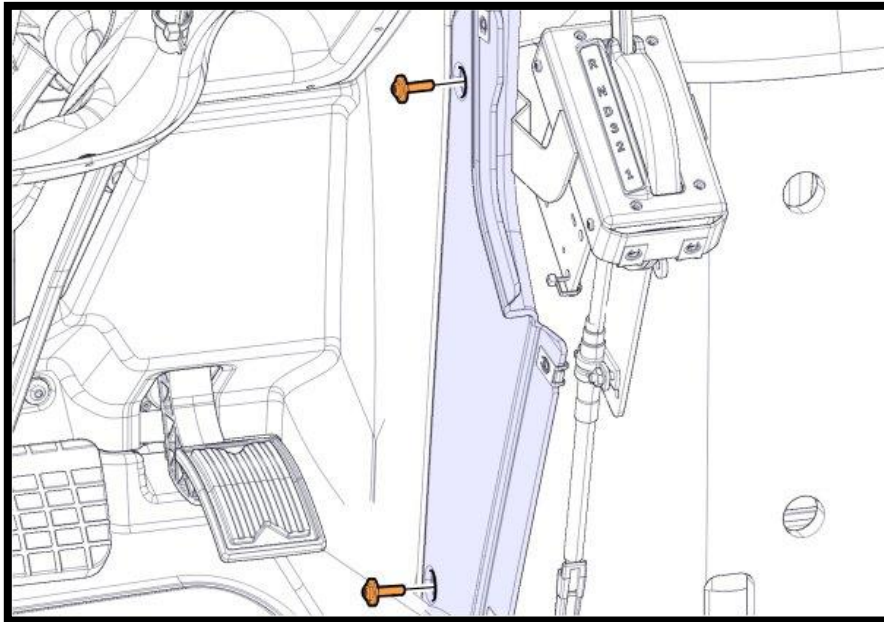

MMD Brake Pressure Switch

14. Remove the panel.

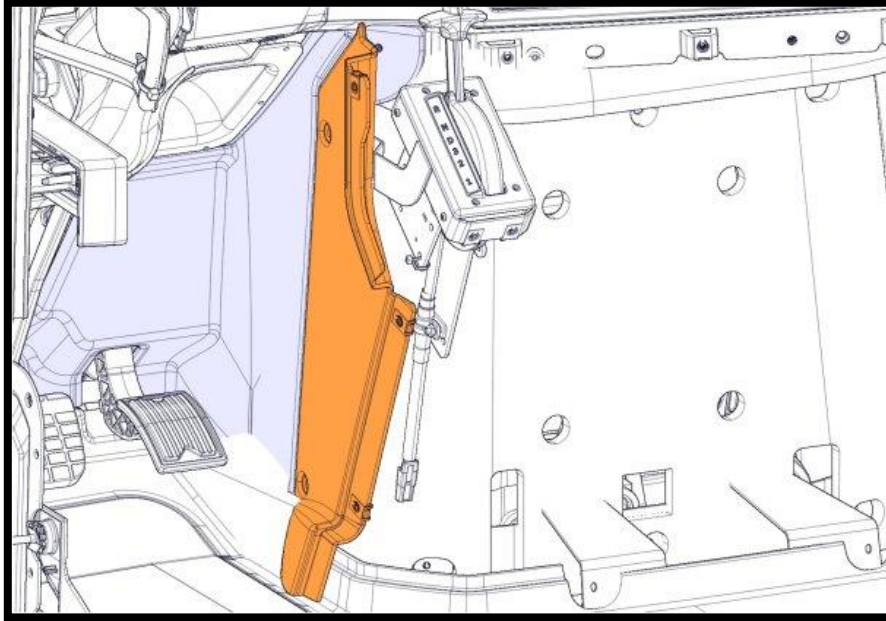

15. Remove the screws.

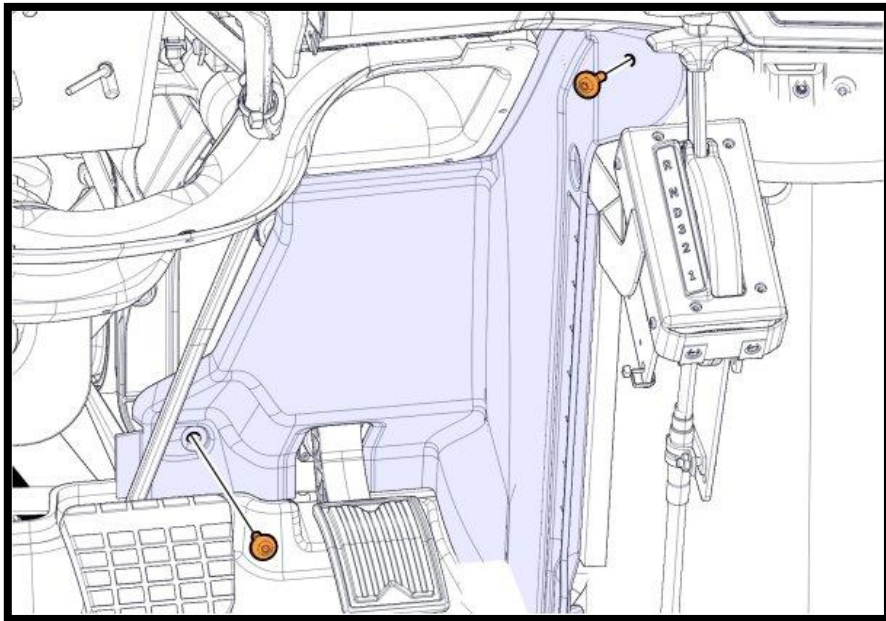

MMD Brake Pressure Switch

16. Remove the panel.

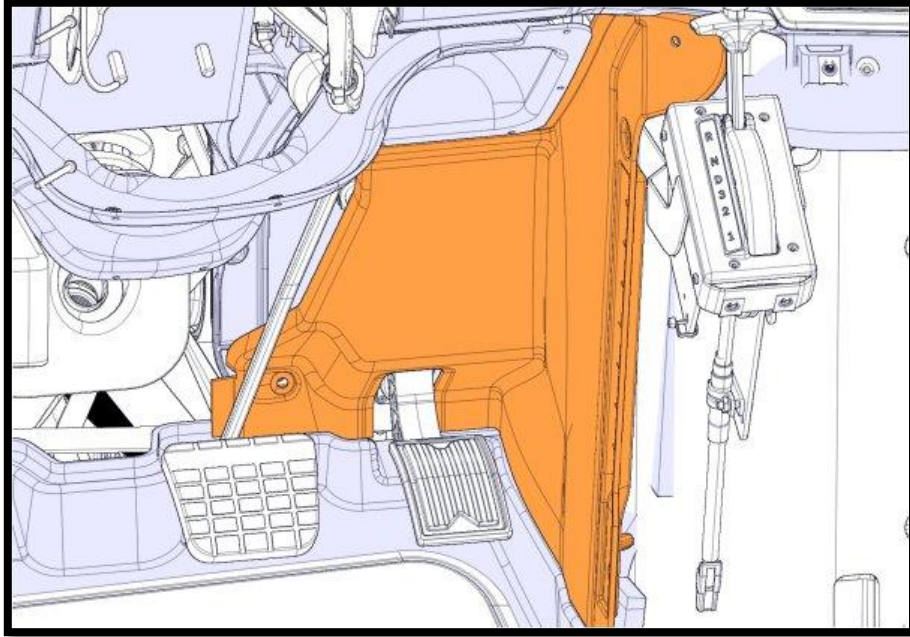

17. Disconnect the connector.

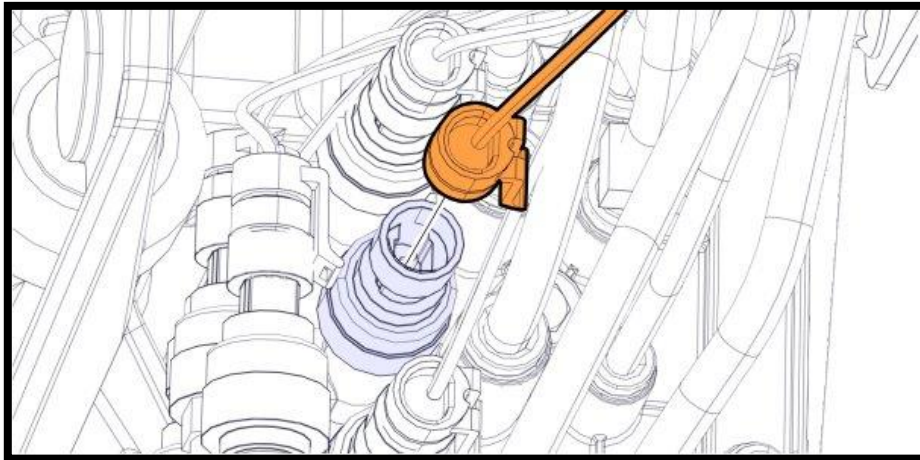

MMD Brake Pressure Switch

18. Remove the switch.

Required material	
DISASSEMBLY TOOL	88870015

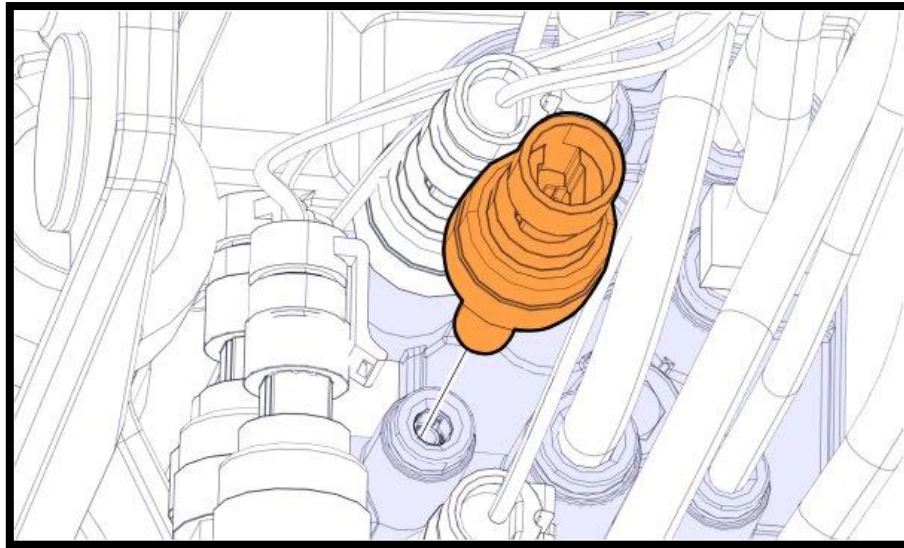

19. Install the switch.

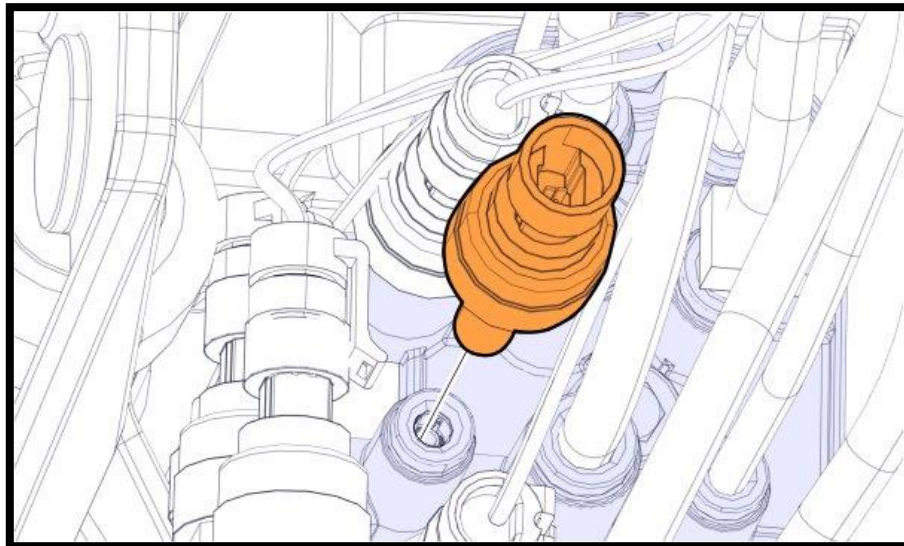

MMD Brake Pressure Switch

20. Connect the connector.

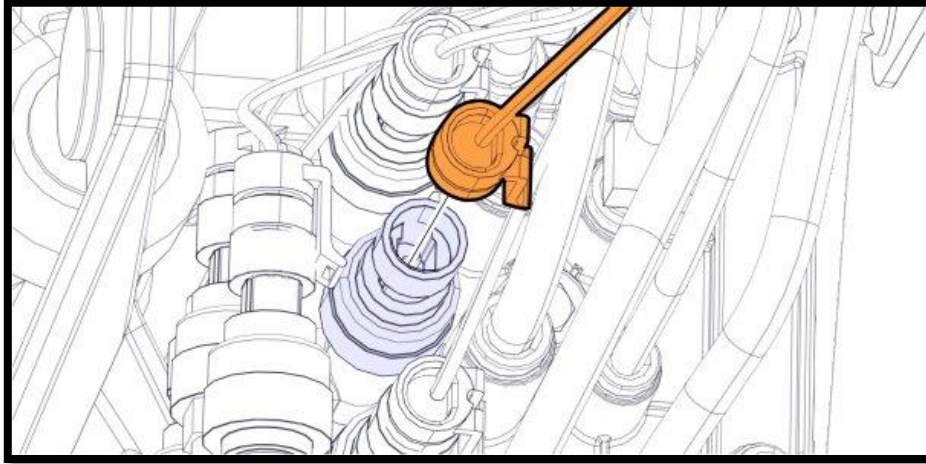

21. Connect the cable to the negative terminal.

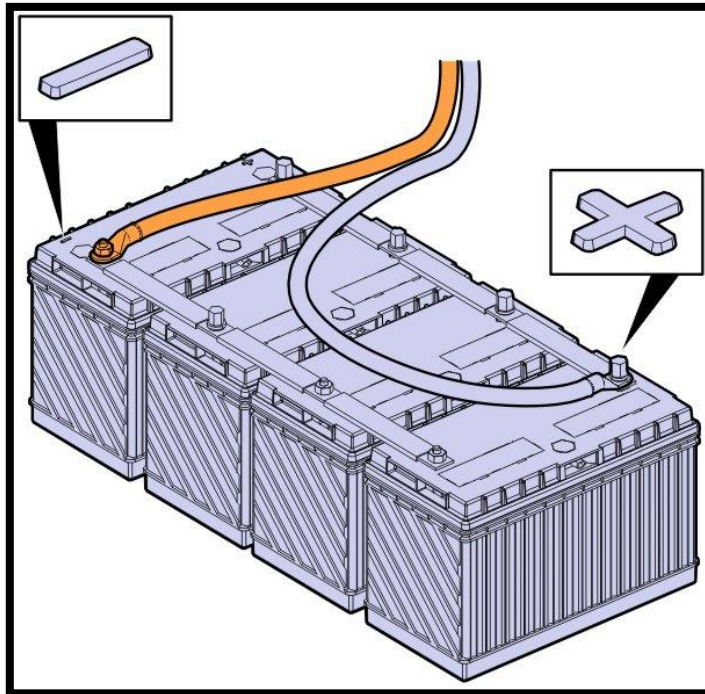

22. Start the engine.
23. Idle engine until the pneumatic system is at operational pressure.
24. Check the air line for leakage.

MMD Brake Pressure Switch

25. Install the panel.

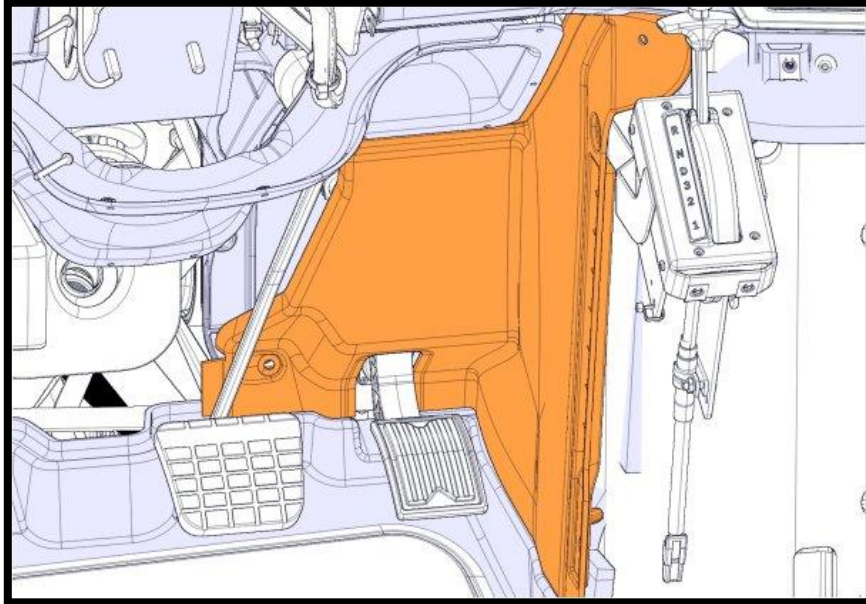

26. Install the screws.

27. Torque tighten the screws.

Tightening torque	
Screw	M5
	6 ± 1.0 Nm
	(4 ± 1) lb·ft

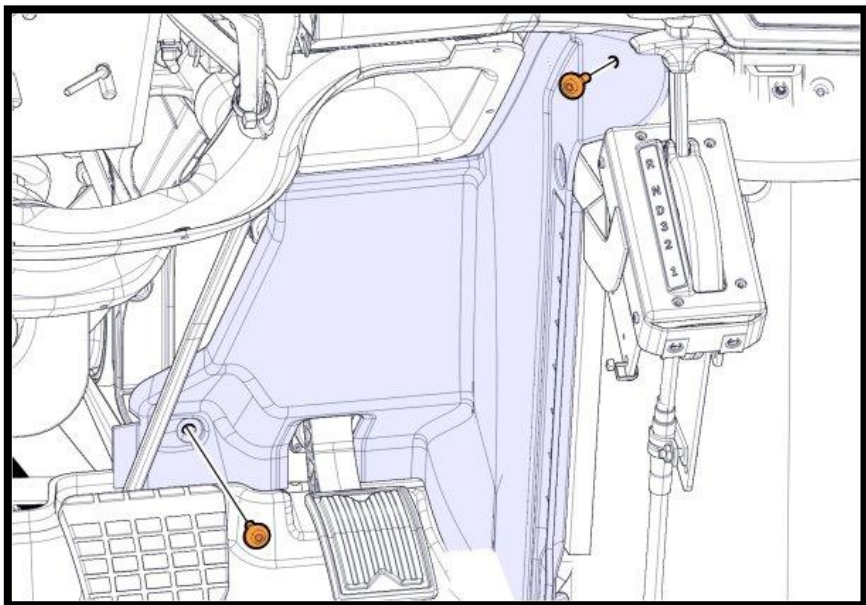

MMD Brake Pressure Switch

28. Install the panel.

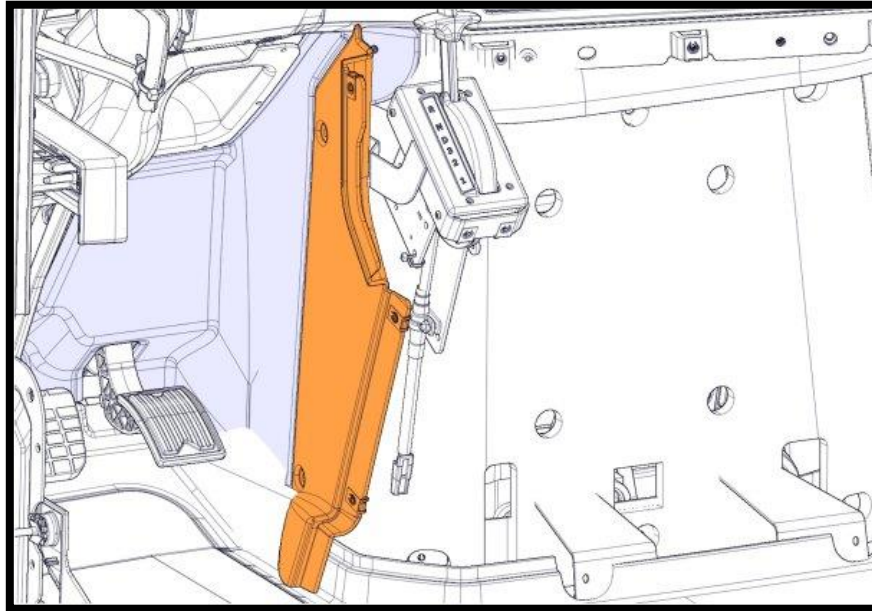

29. Install the screws.

30. Torque tighten the screws.

Tightening torque	
Screw	M5
	6 ±1.0 Nm (4 ±1 lb·ft)

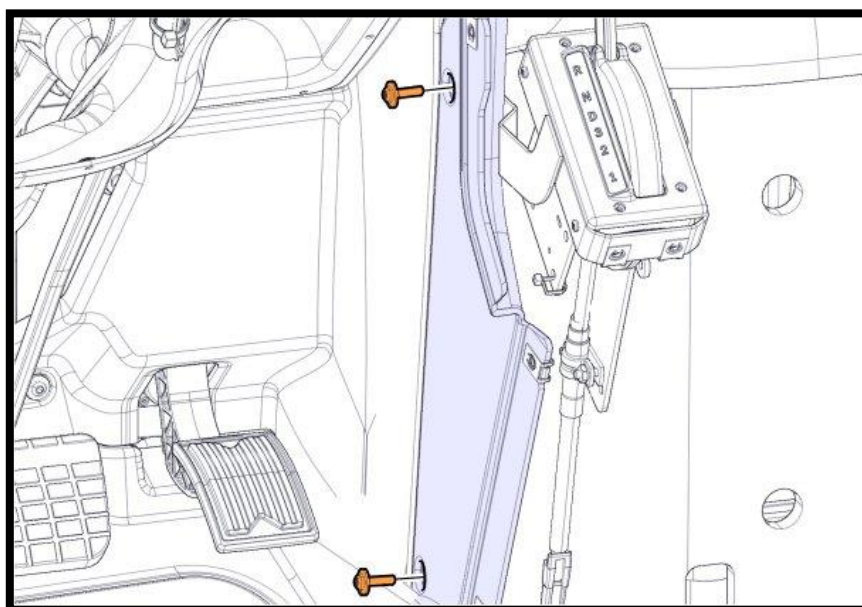

MMD Brake Pressure Switch

31. Install the panel.

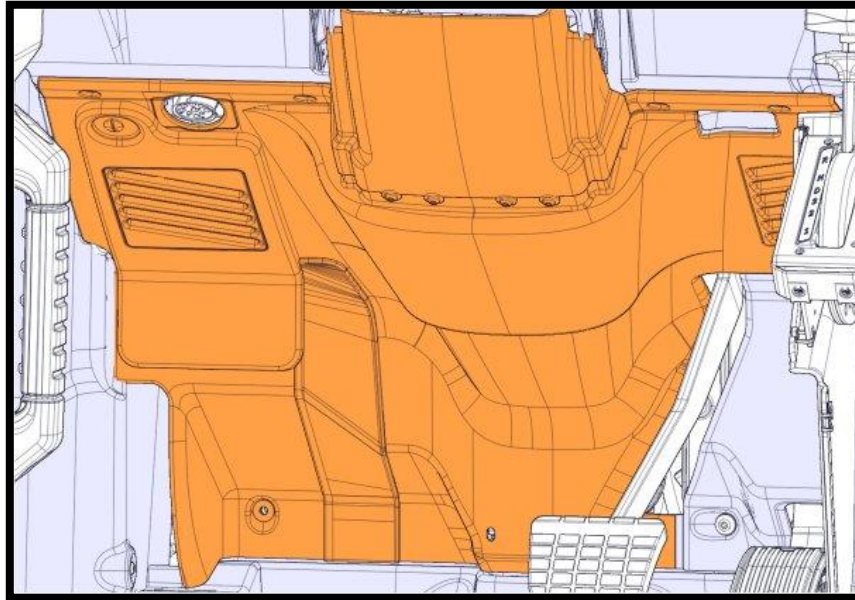

32. Install the screws.
33. Torque tighten the screws.

Tightening torque	
Screw	M5
	6 ± 1.0 Nm (4 ± 1 lb·ft)

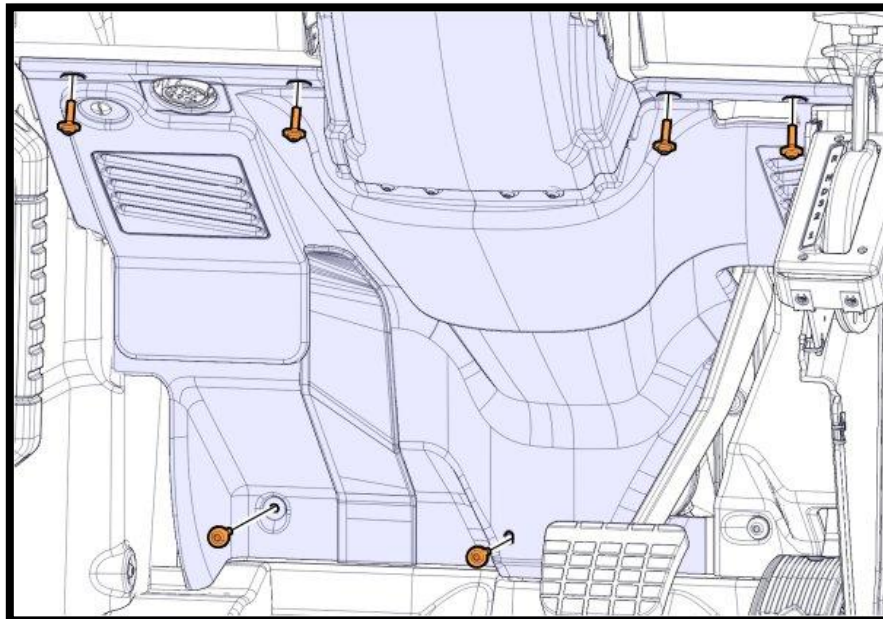

MMD Brake Pressure Switch

34. Install the front panel cover.
35. Install the screws.
36. Torque tighten the screws.

Tightening torque	
Screw	M5
	6 ±1.0 Nm (4 ±1 lb _r ·ft)

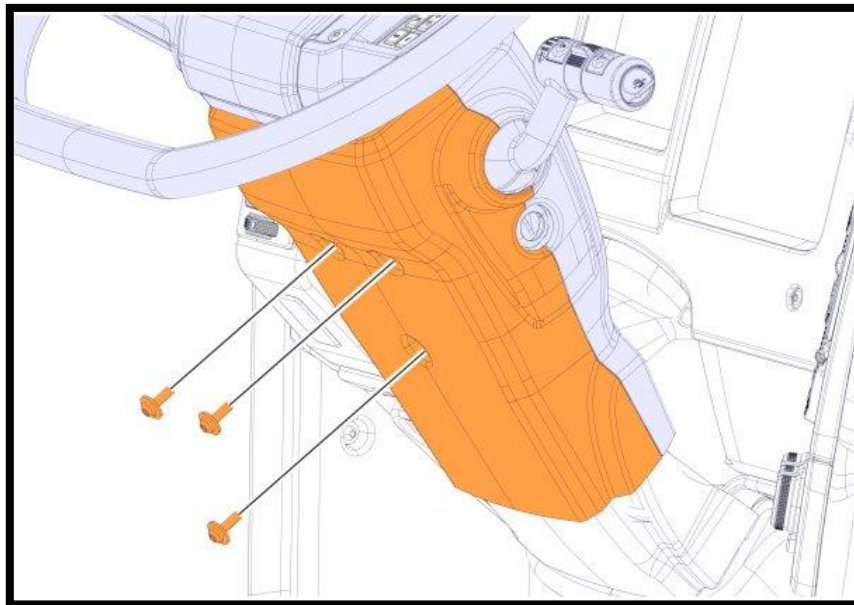

37. Install the panel.

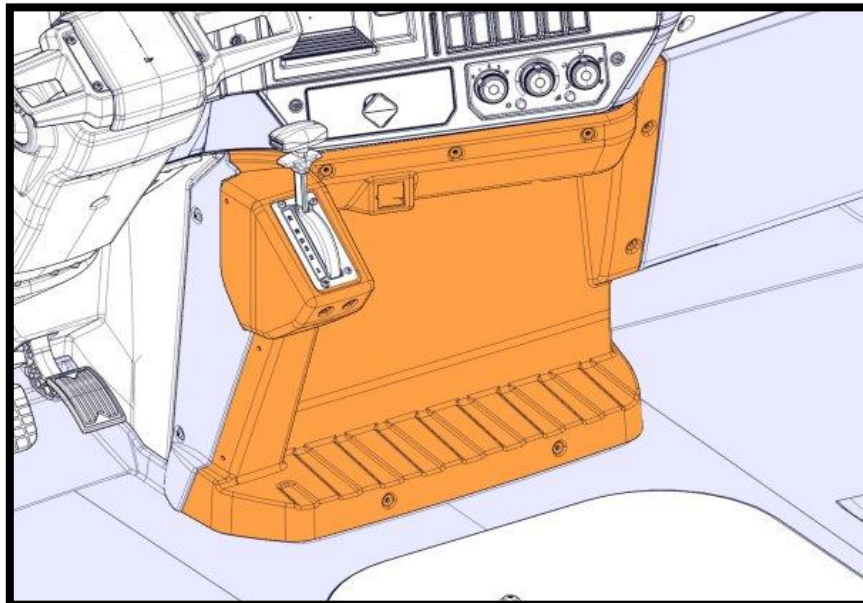

MMD Brake Pressure Switch

38. Install the screws.
39. Torque tighten the screws.

Tightening torque	
Screw	M5
	6 ±1.0 Nm
	(4 ±1 lb _r ·ft)

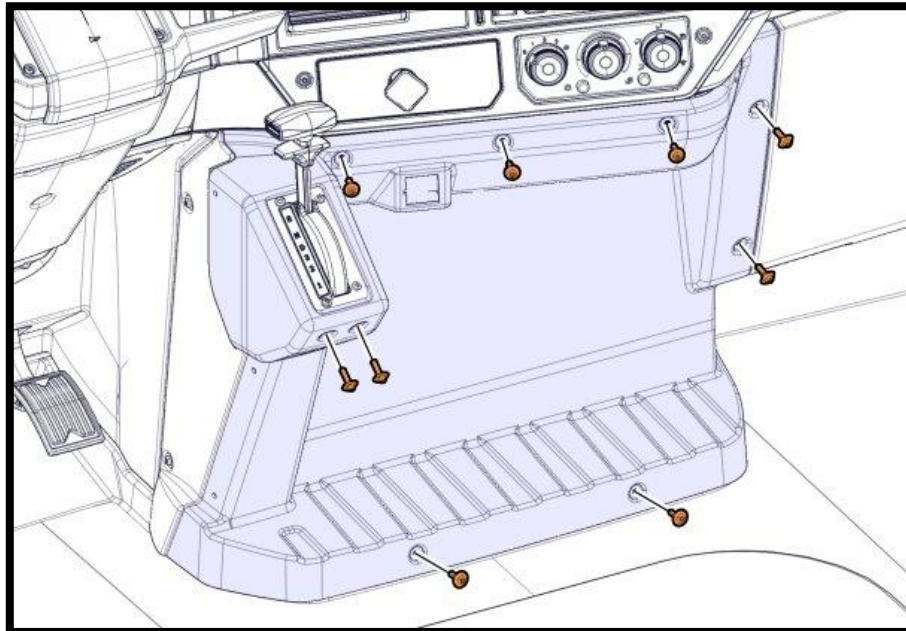

40. Remove the wheel chocks.

