



# Technical Service Bulletin

SUBJECT:  <b>ADDITION OF BELT AND PULLEY REPLACEMENT PROCEDURE FOR CVT F1CJD AND W1CJD- SERVICE MANUAL REVISION</b>		No: <b>TSB-24-23-003</b>	
		DATE: <b>February 2024</b>	
		MODEL: <b>See below</b>	
<b>CIRCULATE TO:</b>	<input type="checkbox"/> GENERAL MANAGER	<input checked="" type="checkbox"/> PARTS MANAGER	<input checked="" type="checkbox"/> TECHNICIAN
<input checked="" type="checkbox"/> SERVICE ADVISOR	<input checked="" type="checkbox"/> SERVICE MANAGER	<input checked="" type="checkbox"/> WARRANTY PROCESSOR	<input type="checkbox"/> SALES MANAGER

## PURPOSE

This TSB provides the addition of the Belt and Pulley Replacement Procedure in the applicable Service Manual sections.

## AFFECTED VEHICLES

2022-2024 Outlander

## AFFECTED SERVICE MANUAL

2022-2024 Outlander Service Manual

## PROCEDURE

Please add the following pages into the affected 2022-2024 Service Manuals, Group 23, TRANSAXLE & TRANSMISSION section:



Copyright 2024, Mitsubishi Motors North America, Inc.

The information contained in this bulletin is subject to change. For the latest version of this document, go to the Mitsubishi Dealer Link, MEDIC, or the Mitsubishi Service Information website ([www.mitsubishitechinfo.com](http://www.mitsubishitechinfo.com)).

CVT<F1CJD, W1CJD>

PREPARATION

**Special Service Tools**

The actual shape of the tools may differ from those illustrated here.

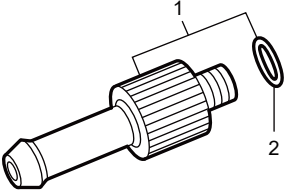
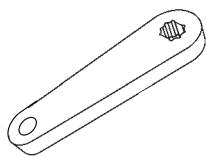
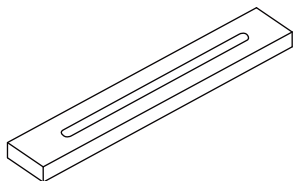
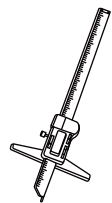
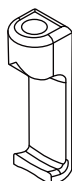
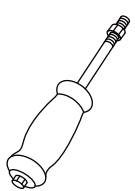
Tool number (TechMate No.) Tool name	Description
1. KV311039S0 ( — ) Charging pipe set 2. KV31103920* ( — ) O-ring	CVT fluid changing and adjustment  <p style="text-align: center;">CF100A28AA00ENG</p>
KV31501600 (J-52508) (-) Transmission range switch adjustment tool	Adjusting transmission range switch position 
KV315J0400 (J-50271) Gauge block	Measuring the total end play  <p style="text-align: center;">CF100A2FAA00ENG</p>
KV315J0500 (J-50272) Digital depth gauge	Measuring the total end play  <p style="text-align: center;">CF100A2GAA00ENG</p>
KV315J0620 (J-51923) J-hook case separator	Removing converter housing  <p style="text-align: center;">CF100A2HAA00ENG</p>
KV315J0610 (J-25721-A) Slide hammer	Removing converter housing  <p style="text-align: center;">CF100A2IAA00ENG</p>

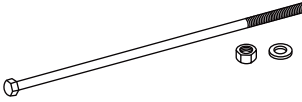
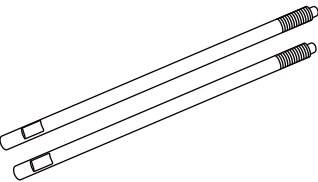
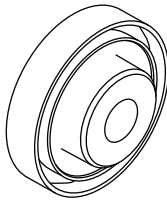
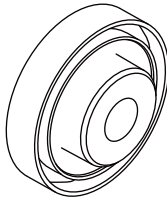
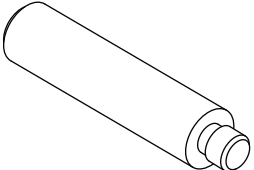
Tool number (TechMate No.) Tool name	Description
KV315J0630 (J-50255-UPD) Slide hammer nut and bolt kit	 <p>CF100A2JAA00ENG</p> Removing converter housing
KV315J0200 (J-51959) CVT assembly guide pins	 <p>CF100A2KAA00ENG</p> Removing/Installing sub-assembly
KV31501200 (J-52281) Output seal installer (case side)	 <p>CF100A2LAA00ENG</p> Installing differential side oil seal (case side)
KV31500910 (J-52282) Output seal installer (torque converter side)	 <p>CF100A2LAA00ENG</p> Installing differential side oil seal (torque converter side)
ST35325000 (J-8092) Universal driver handle	 <p>CF100A2MAA00ENG</p> Use with output seal installer

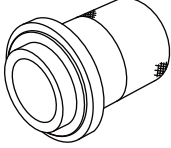
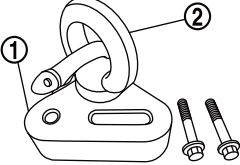
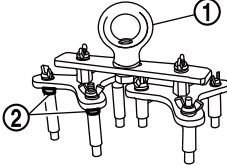
Tool number (TechMate No.) Tool name	Description
KV31500700 (J-50818) Oil pump seal installer	 CF100A2NAA00ENG Installing converter housing oil seal
1. — (J-51595) CVT lifter bracket 2. — (J-51595-1) CVT lifting eye / swivel assembly	 CF100A2OAA00ENG Attaching lift tools
1. KV315J0100 (J-52082) CVT universal lifting fixture 2. — (J-52082-2) Three spacers	 CF100A2PAA00ENG Removing / Installing sub - assembly

\*: The O-ring as a unit part is set as a SST.

**Commercial Service Tools**

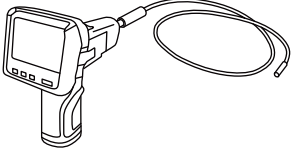
Tool name	Description
Power tool	 CF100A1KAA00ENG Loosening nuts, screws and bolts
— (J-51951) Borescope kit	 CF100A2DAA00ENG CVT belt visual inspection <b>NOTE:</b> Use a commercially available borescope. (The outer diameter of the tip: approximately $\phi 5.5$ mm (0.22 inch), the focal distance: approximately 10 mm (0.4 inch), the number of pixels: approximately 450,000 pixels, and a 90 degree viewing mirror is required.)

## DTC/CIRCUIT DIAGNOSIS

## TRANSMISSION (TCM)

## P0776-00 PRESSURE CONTROL SOLENOID B

**DTC Diagnosis Procedure****1. INSPECT CVT BELT**

Inspect the CVT belt. Refer to [Component Inspection](#).

Is CVT belt OK?

YES >>

[GO TO 2](#)

.

NO >>

[GO TO 3](#)

.

**2. INSTALL NEW CONTROL VALVE**

Install new control valve.

>>

WORK END

**3. REPLACE SUB-ASSEMBLY AND INSTALL NEW CONTROL VALVE**

Replace sub-assembly and install new control valve. Refer to [Disassembly & Assembly](#).

>>

WORK END

## P0841-00 TRANSMISSION FLUID PRESSURE SEN/SW A

**DTC Diagnosis Procedure****1. INSPECT CVT BELT**

Inspect the CVT belt. Refer to [Component Inspection](#).

Is CVT belt OK?

YES >>

[GO TO 2](#)

.

NO >>

[GO TO 3](#)

.

**2. INSTALL NEW CONTROL VALVE**

Install new control valve.

>>

WORK END

**3. REPLACE SUB-ASSEMBLY AND INSTALL NEW CONTROL VALVE**

Replace sub-assembly and install new control valve. Refer to [Disassembly & Assembly](#).

>>

WORK END

## P0965-00 PRESSURE CONTROL SOLENOID B

**DTC Diagnosis Procedure****1. INSPECT CVT BELT**

Inspect the CVT belt. Refer to [Component Inspection](#).

Is CVT belt OK?

YES >>

[GO TO 2](#)

.

NO >>

[GO TO 3](#)

.

**2. INSTALL NEW CONTROL VALVE**

Install new control valve.

>>

WORK END

**3. REPLACE SUB-ASSEMBLY AND INSTALL NEW CONTROL VALVE**

Replace sub-assembly and install new control valve. Refer to [Disassembly & Assembly](#).

>>

WORK END

## P17F1-07 CVT JUDDER (C/V INSPECTION)

**DTC Diagnosis Procedure****1. CHECK DTC PRIORITY**

When DTC P17F1-07 is displayed together with P17F0-07, diagnose first the P17F0-07.

Is "P17F0-07" detected?

YES >>

Perform diagnosis of P17F0-07. Refer to Diagnosis Procedure.

NO >>

[GO TO 2](#)

.

**2. INSPECT CVT BELT**

Inspect the CVT belt Refer to [Component Inspection](#).

Is CVT belt OK?

YES >>

[GO TO 3](#)

.

NO >>

[GO TO 4](#)

.

**3. INSTALL NEW CONTROL VALVE**

Install new control valve. Refer to [Disassembly & Assembly](#).

>>

WORK END

**4. REPLACE SUB-ASSEMBLY AND INSTALL NEW CONTROL VALVE**

Replace sub-assembly and install new control valve.

>>

WORK END

## P2813-00 SELECT SOLENOID

## DTC Diagnosis Procedure

## 1. INSPECT CVT BELT

Inspect the CVT belt. Refer to [Component Inspection](#).

Is CVT belt OK?

YES >>

[GO TO 2](#)

.

NO >>

[GO TO 3](#)

.

## 2. INSTALL NEW CONTROL VALVE

Install new control valve.

>>

WORK END

## 3. REPLACE SUB-ASSEMBLY AND INSTALL NEW CONTROL VALVE

Replace sub-assembly and install new control valve. Refer to [Disassembly & Assembly](#).

>>

WORK END

## Component Inspection

## CVT BELT INSPECTION

## CAUTION:

Never allow any chemicals or fluids other than NS-3 CVT fluid or equivalent to enter the CVT assembly. Never allow any foreign debris, dust, dirt, etc. to enter the CVT assembly.



## NOTE:

Before lifting the vehicle:

- Place the transmission gear selector in Neutral.
- Leave the driver door unlatched.

1. Remove the control valve. Refer to .

2. Secure the right front tire with a suitable strap <sup>①</sup>. This will assist in making the belt turn.

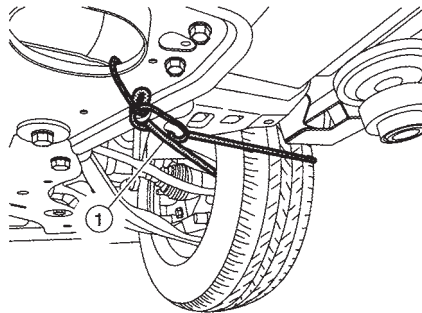

CF100A4UAA00ENG

3. Mark the left front tire with a suitable marking. This will ensure all 360° of the belt is inspected.

4. Using borescope (commercially-available tool) with mirror attachment, visually inspect the entirety of the two sides of the belt ① that come in contact with the pulleys ②. Slowly and carefully turn the left front tire one full turn in the forward rotation to view all of the belt.

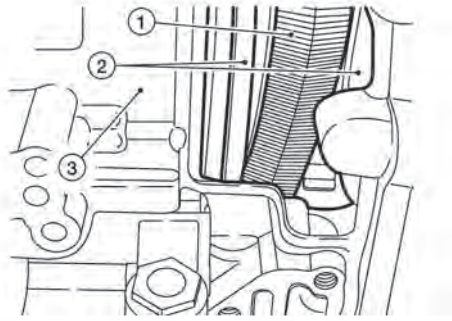

CF100A4VAA00ENG

③	CVT case
---	----------

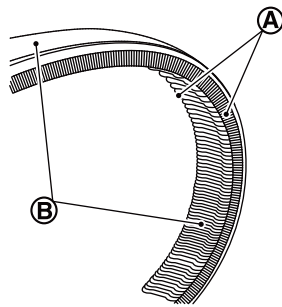

CF100A4WAA00ENG

A	Inspect these sides
B	Never inspect these sides

**CAUTION:**  
If the tire is rotated in the rearward rotation, the camera lens may get caught between the belt and the pulley.

**NOTE:**

- Be sure to remove the protective film from the mirror before the first use.
- Clean the camera lens and mirror before each inspection. Use 90% isopropyl alcohol, and a lens swab from Lens Swab packet J-51963.
- Before inspecting, make sure the camera handle's AA batteries are fresh and the LCD monitor's battery is charged.
- Point the scope up and towards the rear of the vehicle.



1. First inspect the entire 360° of the passenger side of the belt that comes in contact with the pulley. Refer to figures below for examples of normal and excessive wear patterns.

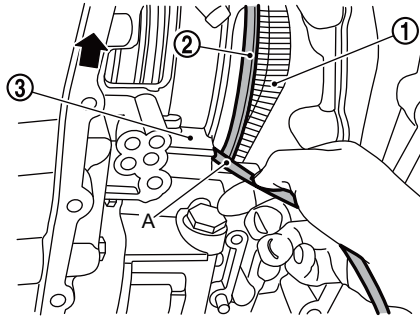

CF100A4XAA00ENG

①	Belt
②	Pulley
③	Transaxle case
A	Camera flexible tube
←	: Front



**NOTE:**

- Insert the camera lens between the CVT case and the pulley.
- Insert the lens approximately 7 inches, and then view the side of the belt that contacts the pulley.
- Holding the borescope with one hand allows for turning the tire with the other hand.

2. If the inspection result is OK on all 360° of the passenger side, inspect all 360° of the driver side of the belt. Refer to figures below for examples of normal and excessive wear patterns.

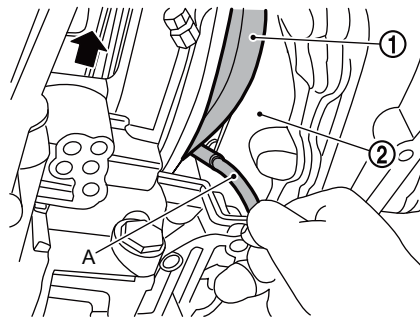

CF100A4YAA00ENG

①	Belt
②	Pulley
A	Camera flexible tube
←	: Front

**BELT WEAR PATTERNS**

Example of OK (normal) wear pattern.

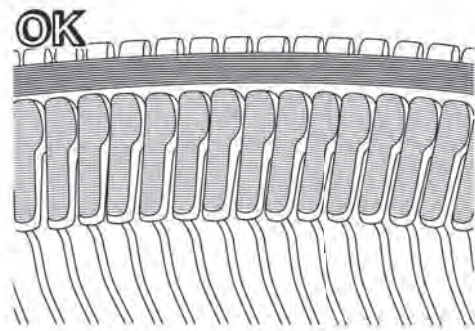

CF100A4ZAA00ENG

- Consistent parallel lines are present across the contact surfaces of each element.

Examples of NG (abnormal) wear patterns.

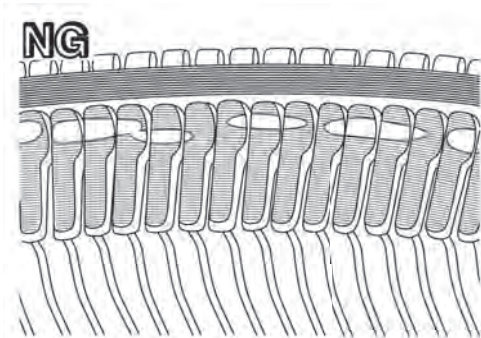

CF100A50AA00ENG

- Contact surfaces of elements show visible scuffing, smeared or non-existent parallel lines, or damage.

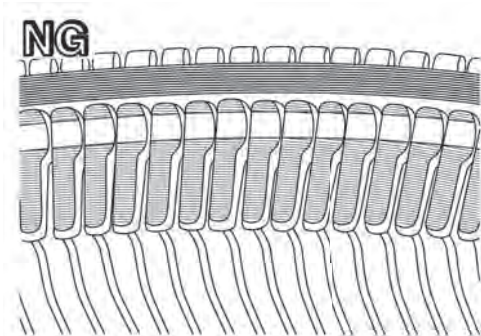

CF100A51AA00ENG

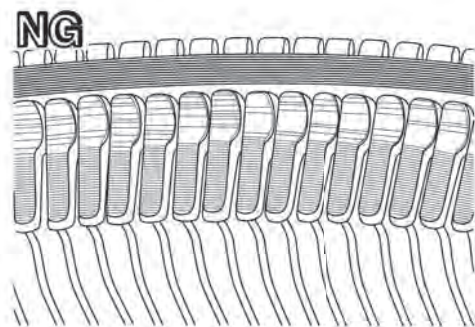

CF100A52AA00ENG

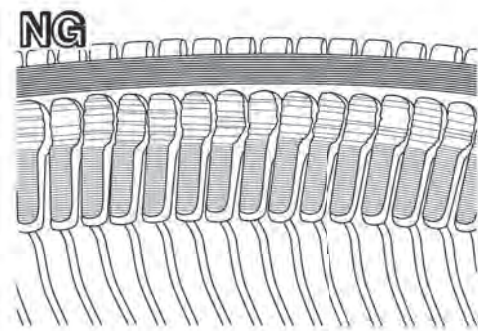

CF100A53AA00ENG

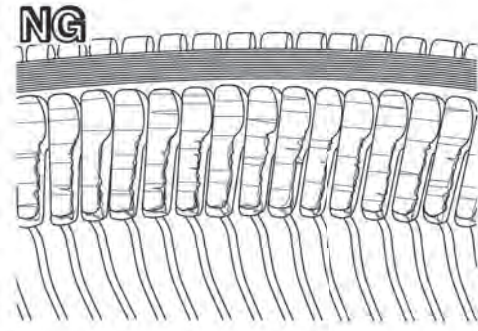

CF100A54AA00ENG

UNIT DISASSEMBLY AND ASSEMBLY

TRANSAXLE ASSEMBLY

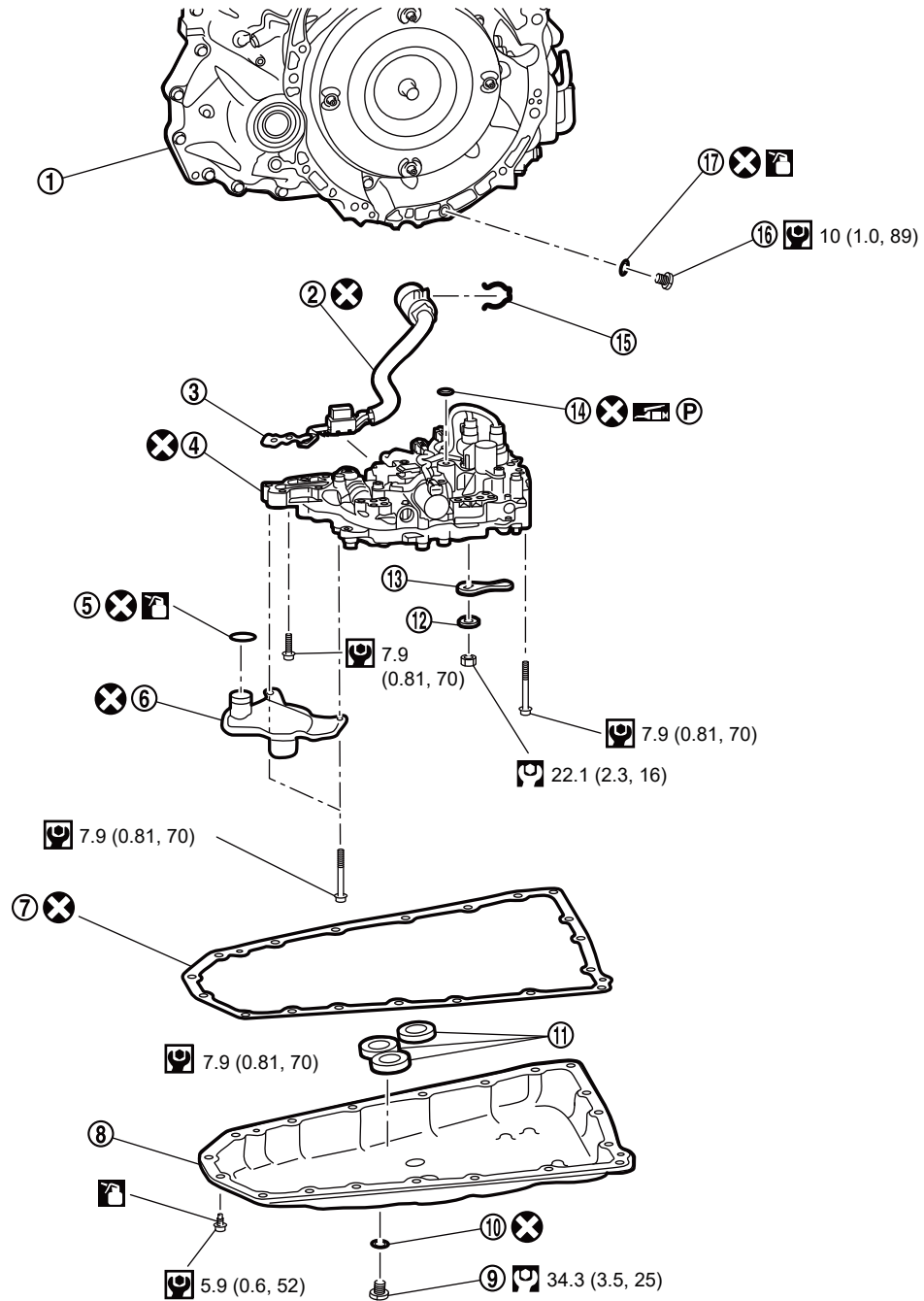

Exploded View

SEC. 311•317



DF100A5MAA00ENG

①	Transaxle assembly	②	Terminal cord assembly	③	CVT fluid temperature sensor bracket
④	Control valve	⑤	O-ring	⑥	Oil strainer assembly
⑦	Oil pan gasket	⑧	Oil pan	⑨	Drain plug
⑩	Drain plug gasket	⑪	Magnet	⑫	Spring washer
⑬	Manual plate	⑭	Lip seal	⑮	Snap ring
⑯	Overflow plug	⑰	O-ring	Ⓐ	Refer to <a href="#">Disassembly &amp; Assembly</a> .

	: Always replace after every disassembly				
	: N·m (kg·m, ft·lb)				
	: N·m (kg·m, in·lb)				
	: Apply CVT fluid				
	: Apply petroleum jelly				

SEC. 311•317•319

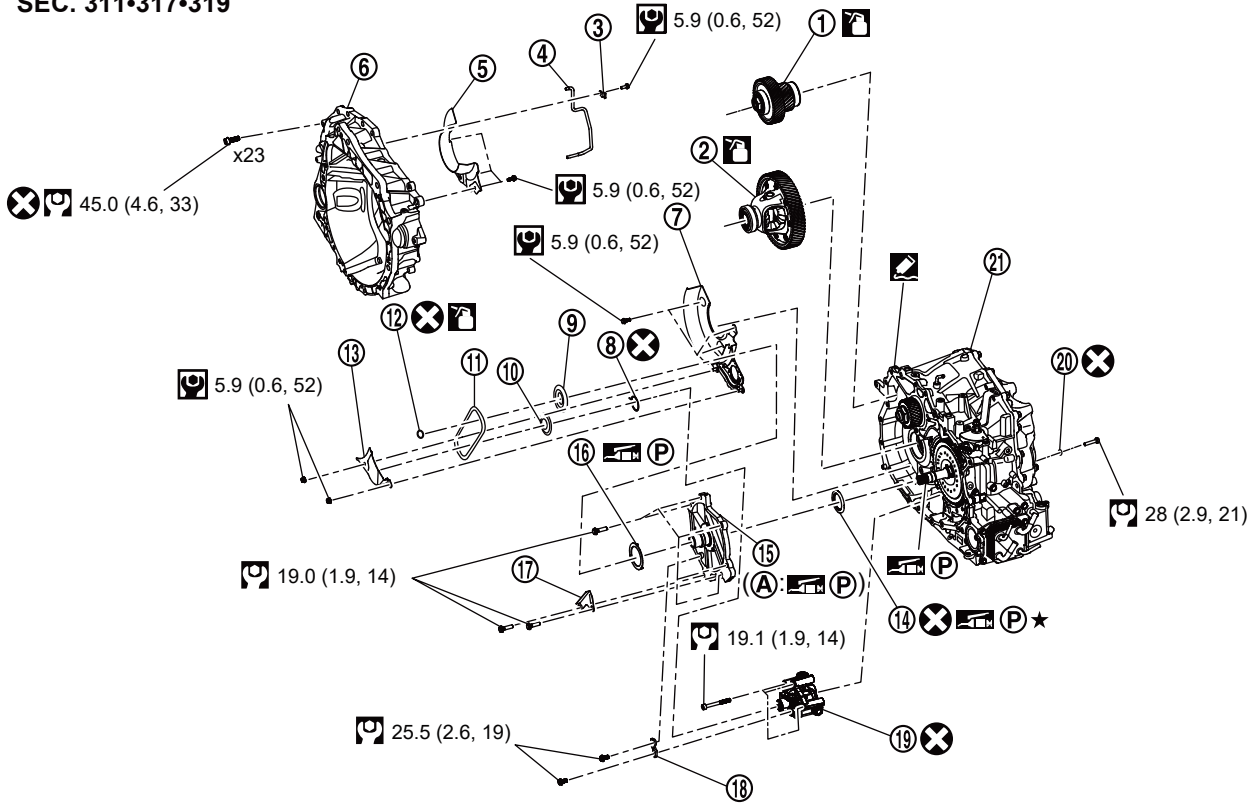

CF100A6JAA00ENG

①	Reduction gear assembly	②	Differential assembly	③	Clip
④	Lubrication tube	⑤	Baffle plate	⑥	Converter housing
⑦	Baffle plate	⑧	Snap ring	⑨	Drive sprocket
⑩	Driven sprocket	⑪	Oil pump chain	⑫	O-ring
⑬	Baffle plate (Chain cover)	⑭	Thrust bearing	⑮	Dummy cover
⑯	Thrust washer	⑰	Chain guide	⑱	Bracket
⑲	Oil pump	⑳	O-ring	㉑	Transaxle case
Ⓐ	Seal ring				
⊗	: Always replace after every disassembly.				
🔧	: N·m (kg·m, ft·lb)				
🔧	: N·m (kg·m, in·lb)				
🛢	: Apply CVT fluid				
🛢	: Apply Loctite 5460 or equivalent				
🛢	: Apply petroleum jelly				
★	: Select with proper thickness				

SEC. 311

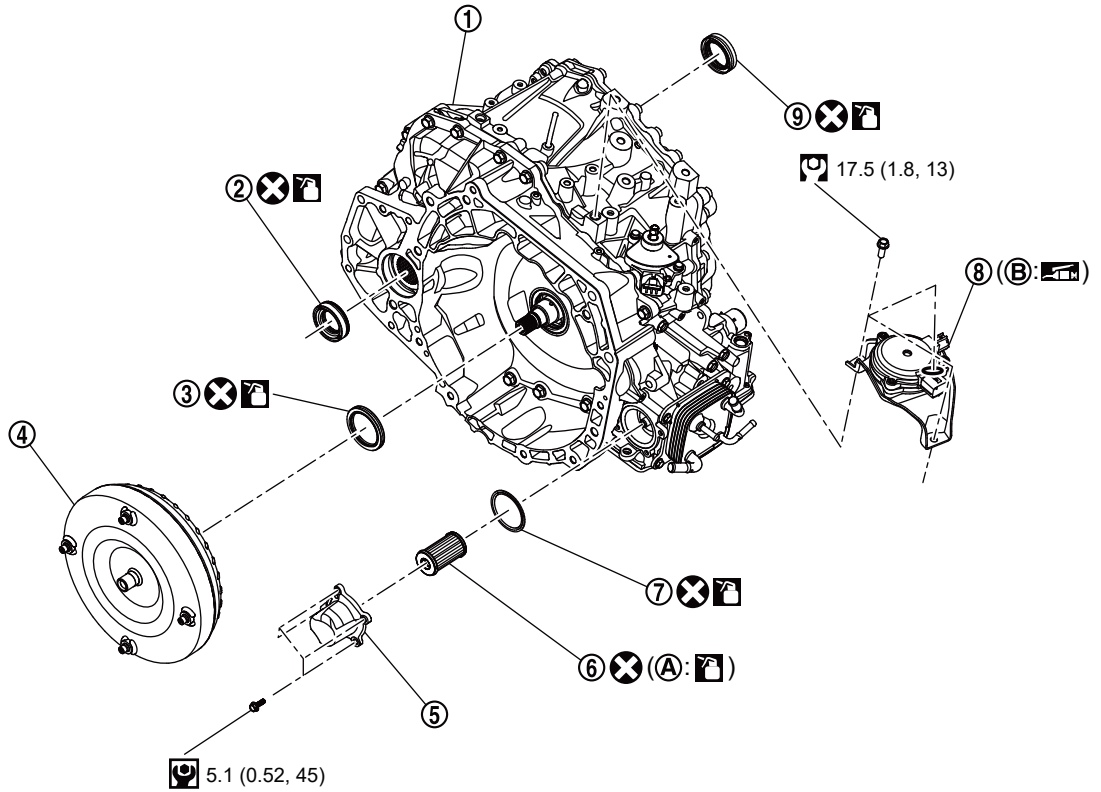

CF100A6KAA00ENG

①	Transaxle assembly	②	Differential side oil seal	③	Converter housing oil seal
④	Torque converter	⑤	Fluid filter cover	⑥	CVT fluid filter
⑦	O-ring	⑧	Shift actuator	⑨	Differential side oil seal
Ⓐ	Grommet seal	Ⓑ	Spline part		
⊗	: Always replace after every disassembly.				
Ⓜ	: N-m (kg-m, ft-lb)				
Ⓜ	: N-m (kg-m, in-lb)				
Ⓜ	: Apply CVT fluid				
Ⓜ	: Apply lithium-based grease including molybdenum disulphide				

SEC. 311-319

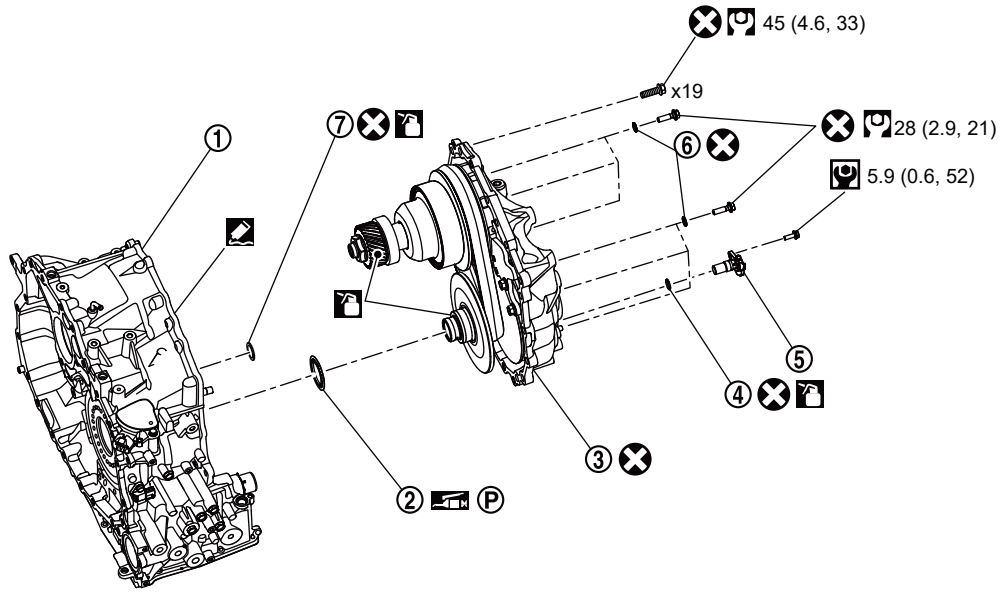

CF100A6LAA00ENG

①	Transaxle case	②	Thrust bearing	③	Sub-assembly
④	O-ring	⑤	Primary speed sensor	⑥	O-ring
⑦	O-ring				
⊗	: Always replace after every disassembly.				
⊙	: N·m (kg·m, ft·lb)				
⊙	: N·m (kg·m, in·lb)				
🛢	: Apply CVT fluid				
🛢	: Apply Loctite 5460 or equivalent				
🛢	: Apply petroleum jelly				



**Disassembly & Assembly****CAUTION:**

Perform the following items when replacing the control valve.

- Check that the part number and serial number <sup>(A)</sup> of the new control valve are identical to those of the attached CD.

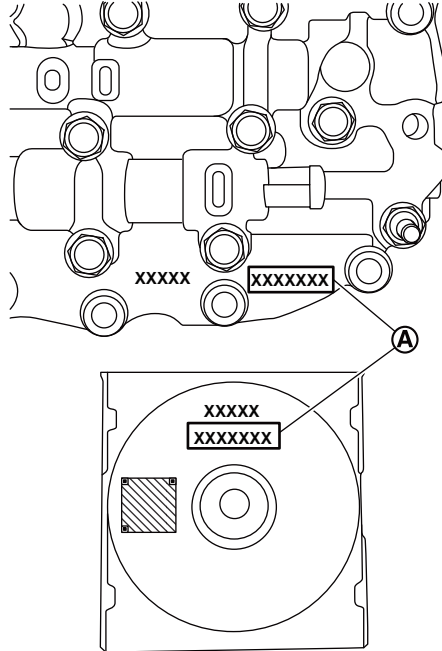

CF100A5NAA00ENG

- If old QR code sticker is affixed to shift actuator, remove the QR code sticker and affix new QR code sticker included with new control valve.

**NOTE:**

The CD provided with the new control valve contains important calibration data that must be installed with M.U.T.-III SE after installation of the new control valve. Never discard the CD.

1. Disconnect battery negative terminal.
2. Remove drain plug from oil pan and then drain the CVT fluid.
3. Remove drain plug gasket.
4. Remove the oil pan bolts, and then remove the oil pan and oil pan gasket.
5. Remove the magnets from the oil pan.

**NOTE:**

Be sure to note the location of the magnets in the oil pan before removal.

6. Use a suitable tool (A) between the manual plate ③ and bolt ② and remove lock nut ①. Remove spring washer ② and manual plate from manual shaft ③.

**CAUTION:**

- Insert suitable tool between the manual plate and bolt and remove lock nut while holding the manual plate in a fixed position.
- Be sure not to damage the control valve while using suitable tool.

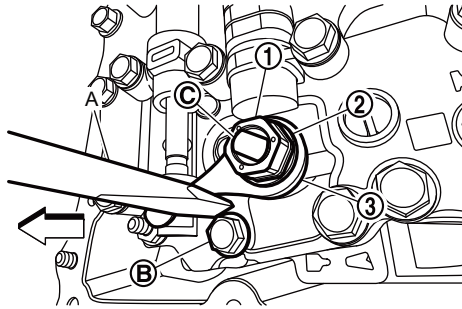

CF100A5OAA00ENG



7. Remove the oil strainer assembly bolts ① and remove the oil strainer assembly.

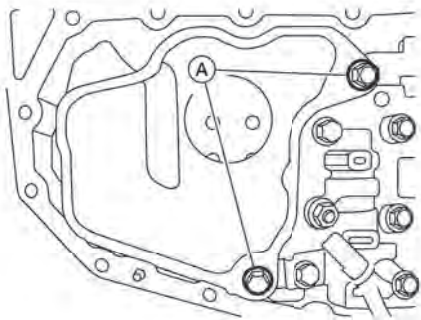

CF100A5PAA00ENG

8. Remove CVT fluid temperature sensor bracket ① and disconnect control valve harness connector ②.

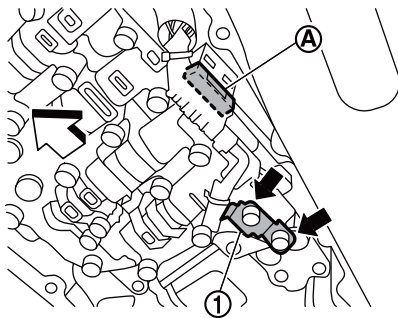

CF100A6MAA00ENG

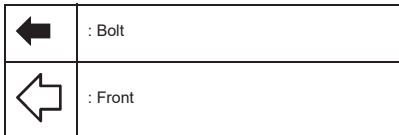

9.Remove bolts.

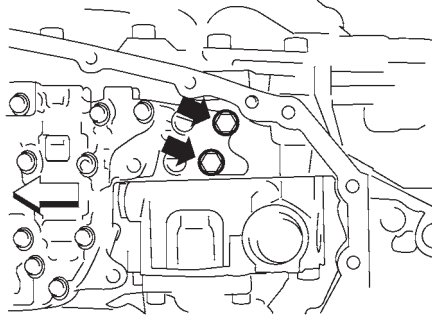

CF100A5RAA00ENG



10.Disconnect control valve harness connector (A).

11.Remove the control valve bolts (A) and (B), and then remove the control valve from the transaxle case.

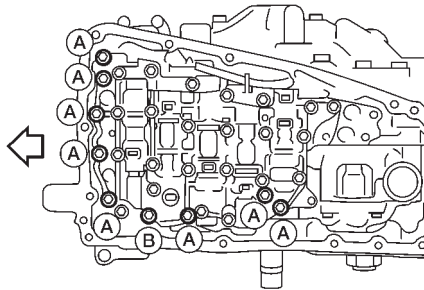

CF100A5SAA00ENG



**CAUTION:**

Never drop the control valve, manual valve.



**NOTE:**

Control valve bolt heads may be marked with a number "7". Bolts marked as "7" are the bolts that need to be removed in order to remove the control valve.

12.Remove the lip seal (1) from the transaxle case.

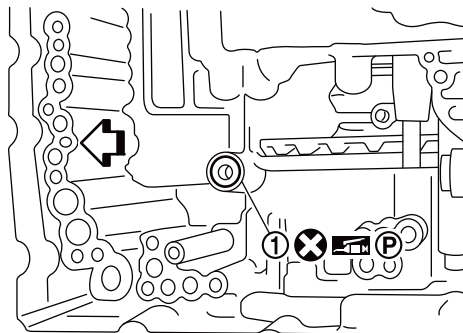

CF100A5TAA00ENG



13. Temporarily install the oil pan gasket and oil pan with four oil pan bolts (  ) to corners of the oil pan, hand tight.

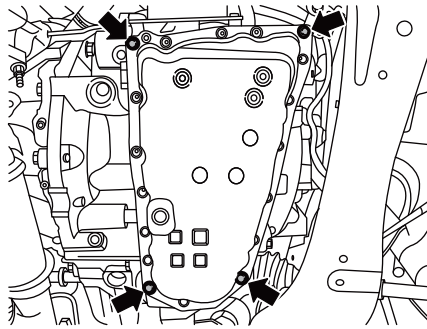

CF100A6NAA00ENG

**NOTE:**  
It is not necessary for the control valve to be installed, a new one will be installed later in the service procedure.

14. Remove the CVT from the vehicle.

15. Mount the CVT on a workbench with the oil pan side down.

**NOTE:**  
Use plastic or wood blocks to stabilize the CVT assembly on the work bench if needed.

**CAUTION:**  
Be sure not to deform the oil pan.

16. Remove the torque converter <sup>①</sup>.

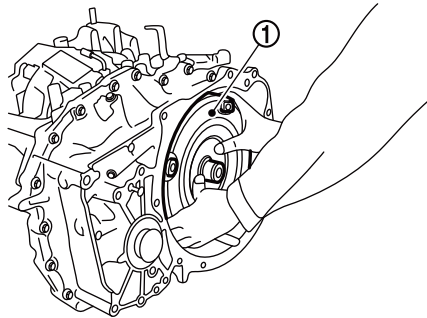

CF100A6OAA00ENG

17. Drain the CVT fluid out of the torque converter <sup>①</sup>.

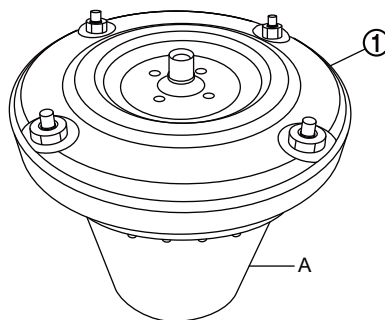

CF100A6PAA00ENG

A	: Drain pan
---	-------------

18. Remove mounting bolt (➡) and remove primary speed sensor ① from transaxle assembly.

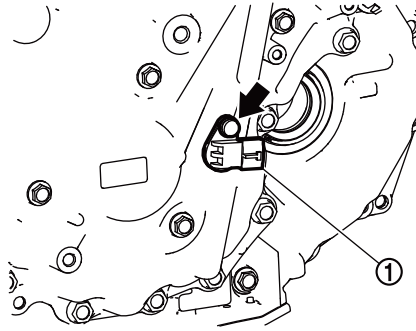

CF100A6QAA00ENG

**CAUTION:**

Never impact the primary speed sensor when removing or installing primary speed sensor.

19. Remove bolts ① from shift actuator and remove shift actuator.

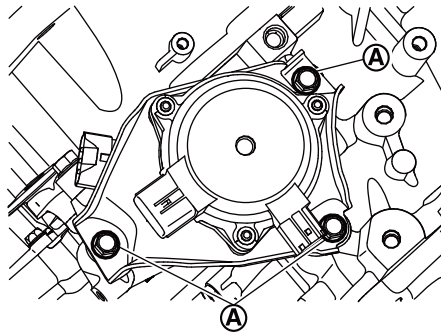

CF100A5FAA00ENG

20. Place the CVT with the converter housing side up and remove the converter housing bolts.

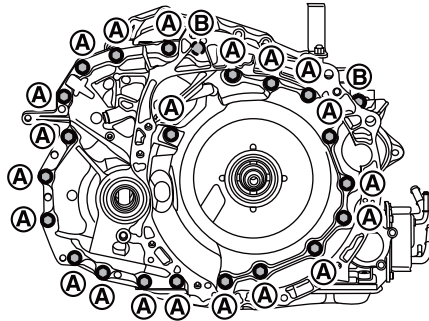

CF100A6RAA00ENG



**NOTE:**

- These bolts will be replaced with new ones and will not be reused.
- Apply rust remover to the dowel pins if needed.

①	: Front bolts
②	: Back side bolts

21. Separate and then remove the converter housing from the transaxle case. Use the slide hammer [SST: KV315J0610 (J-25721-A)] (A), slide hammer nut and bolt kit [SST: KV315J0630 (J-50255-UPD)] (B), and J-hook case separator [SST: KV315J0620 (J-51923)] (C) at the cut out areas similar to the one shown in figure.

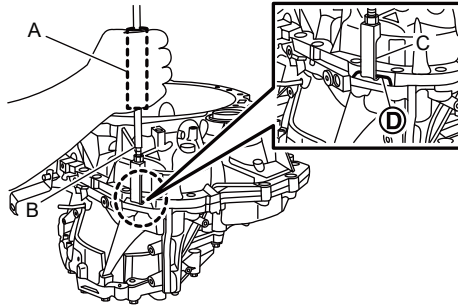

CF100A6SAA00ENG

Ⓓ : Cutout area (total 3 places)

**CAUTION:**  
 Never use a pry-bar, chisel, etc. to separate the converter housing from the transaxle case.

22. Check that retaining pin of manual shaft ① locates on the original position.

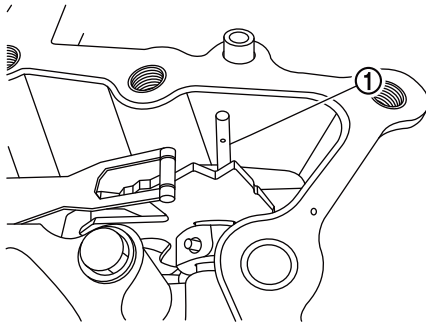

CF100A6TAA00ENG

23. Remove the O-ring ① from the input shaft.

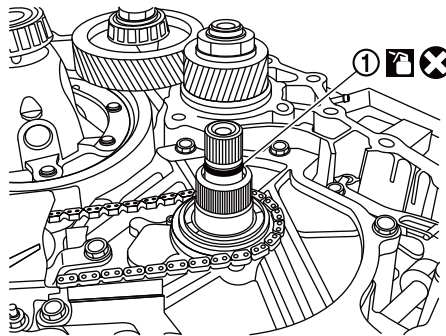

CF100A6UAA00ENG

24. Carefully remove the reduction gear assembly ① and the differential assembly ②.

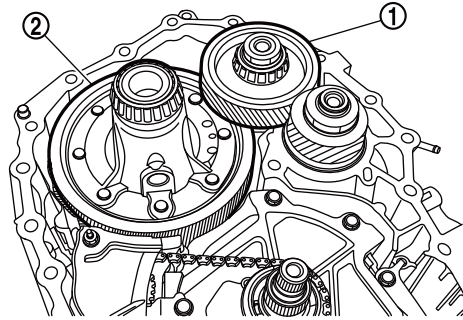

CF100A6VAA00ENG

25. Remove the following oil seals using suitable tool:

**CAUTION:**

Be careful not to damage any of the seal bore surfaces.

- Differential side oil seal ① of transaxle case

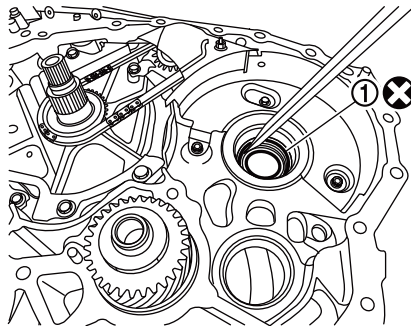

CF100A6WAA00ENG

- Converter housing oil seal ①

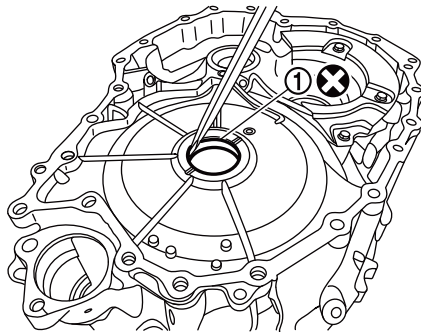

CF100A6XAA00ENG

- Differential side oil seal ① of converter housing

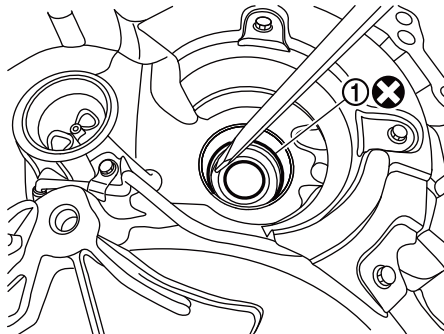

CF100A6YAA00ENG

26. Remove the baffle plate (chain cover) ①.

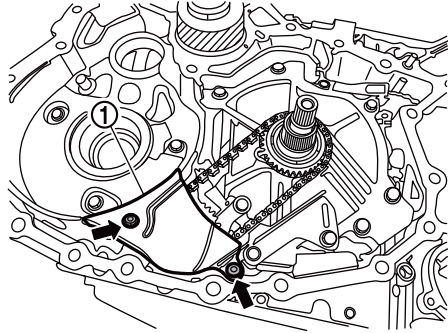

CF100A6ZAA00ENG



27. Remove the oil pump chain ①, driven sprocket ② and drive sprocket ③ as one assembly in the following procedure.

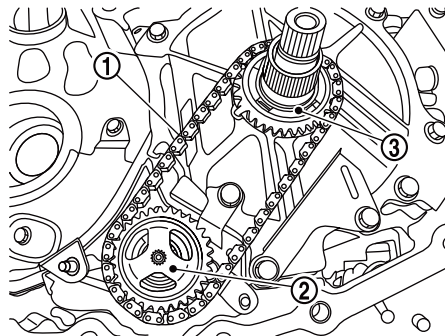

CF100A70AA00ENG

1. Spread the snap ring ① using snap ring pliers.

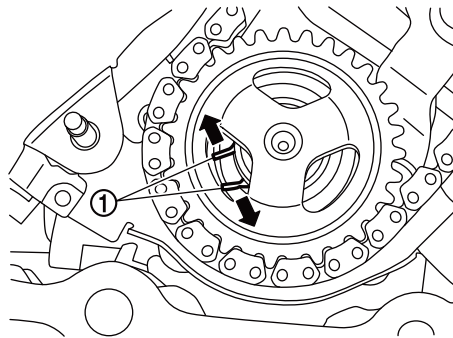

CF100A71AA00ENG

2. Lift the driven sprocket and the drive sprocket horizontally.

**CAUTION:**

The drive sprocket has a specific top and bottom. Keep the sprockets and chain together after they are removed.



28.Remove the thrust washer ①.

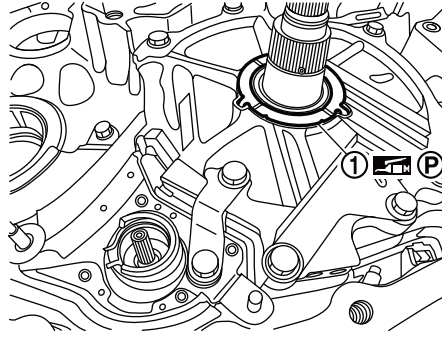

CF100A72AA00ENG

29.Remove the snap ring ①.

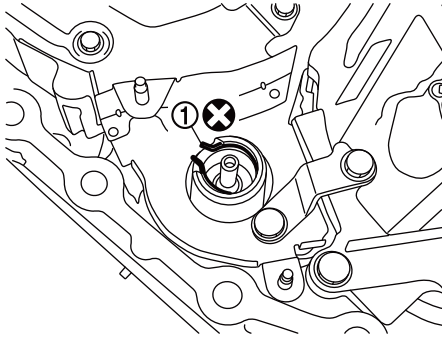

CF100A73AA00ENG

30.Remove the bracket ①.

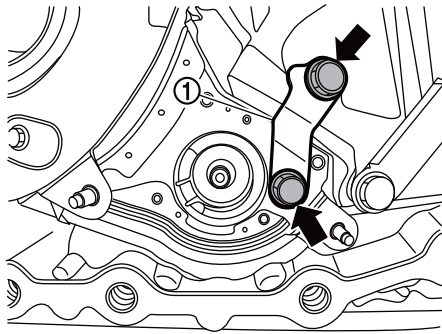

CF100A74AA00ENG



31.Remove the baffle plate ①.

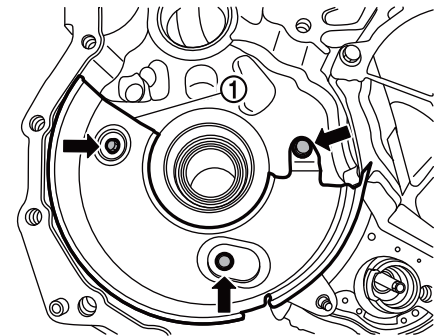

CF100A75AA00ENG

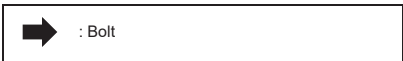

32. Remove the chain guide ①.

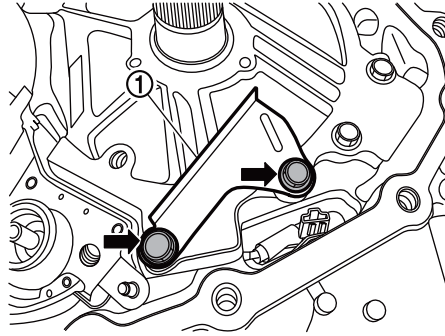

CF100A76AA00ENG



33. Remove the dummy cover ①.

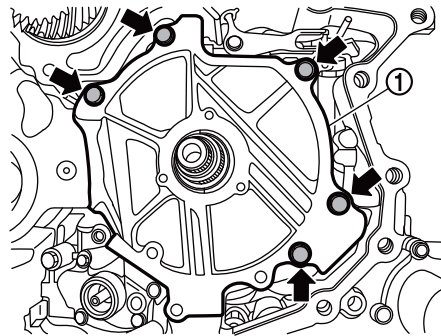

CF100A77AA00ENG

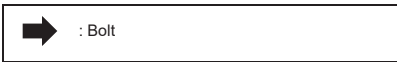

**CAUTION:**

- Never grasp the input shaft and lift it.
- Never remove the seal rings ①.

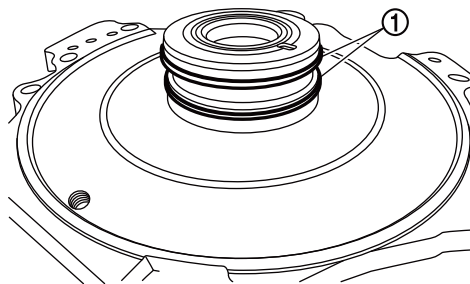

CF100A78AA00ENG

34. Remove the thrust bearing ① from clutch assembly. And wipe any metallic debris off of the face of the input speed sensor ③.

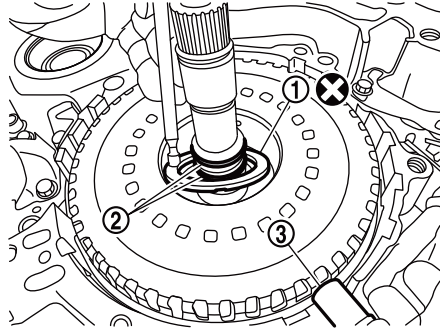

CF100A79AA00ENG

**CAUTION:**

Be careful not to damage seal rings ②.

35. Remove the oil pump fixing bolts (4 pieces) and then remove the oil pump ①.

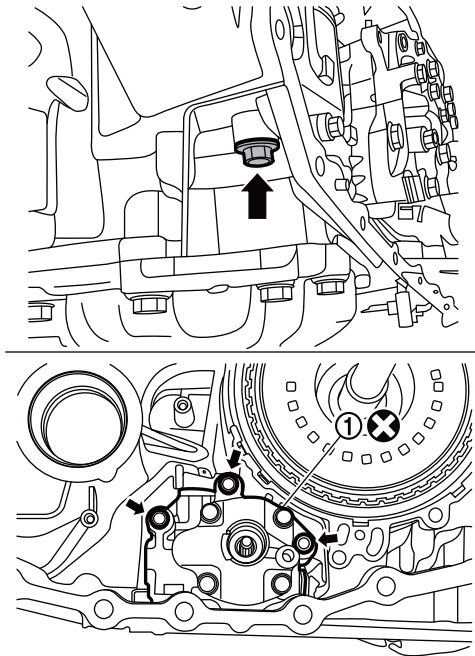

CF100A7AAA00ENG

 : Bolt

36.Remove CVT fluid filter as follows:

1. Remove the bolts (➡) and then remove the fluid filter cover ①.

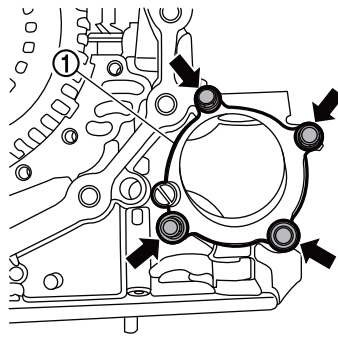

CF100A7BAA00ENG

2. Remove the CVT fluid filter ① with grommet seal ③ and O-ring ②.

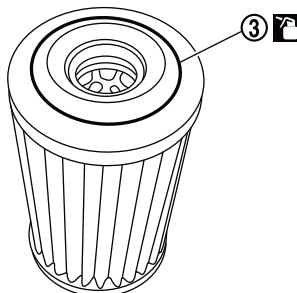
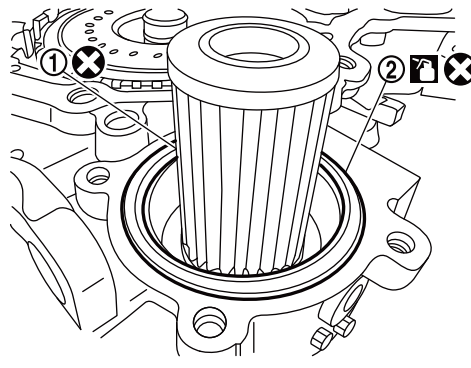

CF100A7CAA00ENG

37.Thoroughly clean the mating surfaces of the transaxle case and torque converter housing.



**NOTE:**

A plastic scraper can be used.

**CAUTION:**

- Never use sanding discs, similar abrasive tools, or metal blades.
- Use parts cleaner or equivalent solvent and lint-free paper only.
- Make sure the parts cleaner or solvents used are compatible with local regulations.
- Prevent debris from entering in the CVT.

38. Make sure rust and debris have been cleaned off of dowel pins **(A)** and receiving holes **(B)**.

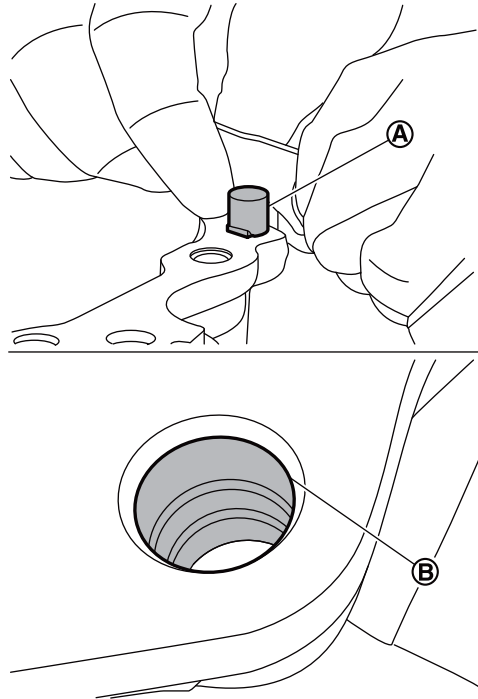

CF100A7DAA00ENG

**NOTE:**

Use small wire brush or similar tool at the inside surface of dowel pin holes. Never scrape transaxle case mating surfaces.

39. Remove the temporarily attached oil pan gasket and oil pan.

40. Clean the oil passages in the transaxle case, dummy cover, and CVT fluid filter area.

**NOTE:**

- Parts cleaner or a suitable cleaning solvent and compressed air will be used to clean out fluid passages in the CVT assembly.
- Make sure the parts cleaner or solvents are compatible with local regulations.

**CAUTION:**

- Wear eye / face protection when using compressed air and cleaning fluids.
- Regulate air pressure up to a maximum of 517 kPa (5.27 kg/cm<sup>2</sup>, 75 psi).

1. Clean the area where the CVT fluid filter fits **(A)** and the fluid passages **(B)** to and from the filter.

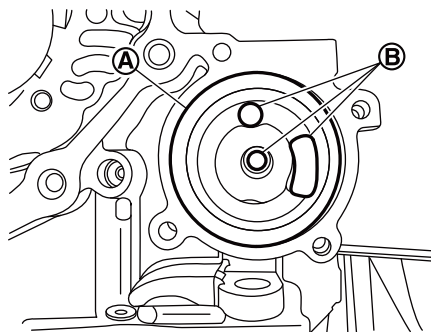

CF100A7EAA00ENG

**CAUTION:**

Make sure the old filter grommet seal is removed.

2. Spray parts cleaner in all fluid passages <sup>(A)</sup> of the transaxle case where shown in figure.

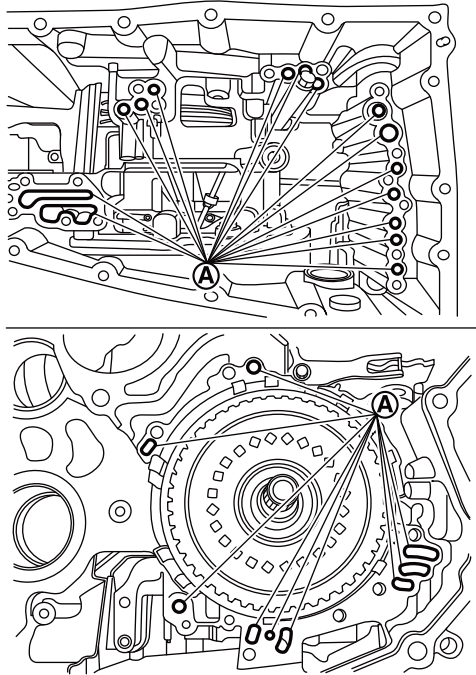

CF100A7FAA00ENG

**CAUTION:**  
Never spray parts cleaner into the clutch assembly.

3. Apply compressed air in the same passage.

**CAUTION:**  
Never stand in front of the passages while using compressed air.

41. Temporarily install fluid filter cover.

42. Install the O-ring <sup>(1)</sup> to the oil pump mounting bolt. (Only for the bolt installed from the outside of the transaxle case)

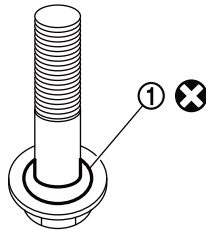

DF100A7GAA00ENG

**CAUTION:**  
Never reuse the O-ring.

43. Install the oil pump on the transaxle case and tighten the mounting bolts to the specified torque. (One of the oil pump retaining bolts is installed from the outside of the transaxle case in the rear part of the oil pump.)

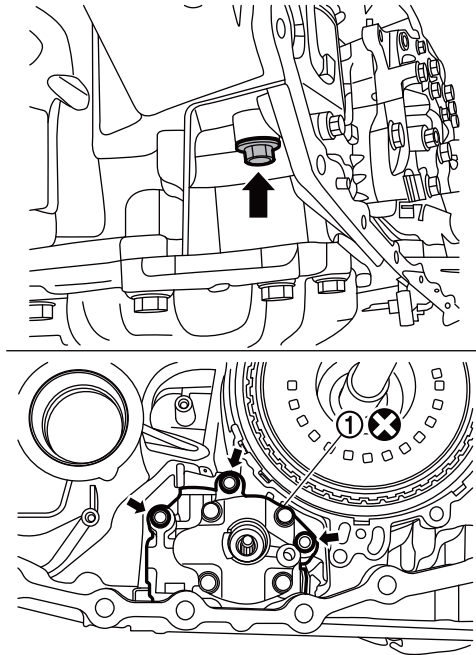

CF100A7AAA00ENG

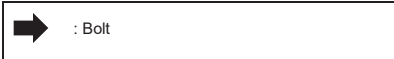

**CAUTION:**  
Never reuse the oil pump.

44. Install the snap ring ①.

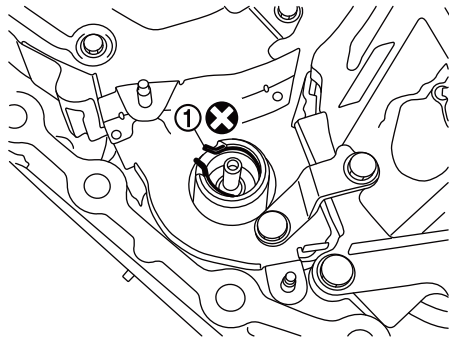

CF100A73AA00ENG

**CAUTION:**  
Never reuse the oil pump snap ring.

45. Temporarily install the dummy cover ① with 3 bolts (➡).

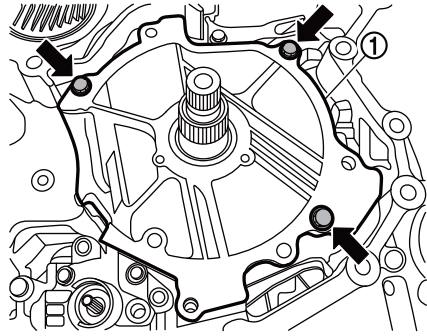

CF100A7HAA00ENG

**CAUTION:**

- Never install the thrust bearing to the clutch assembly bore at this time.
- If cover does not seat flush, refer to trouble shooting. Refer to [Trouble Shooting](#).

46. Temporarily install the converter housing onto the transaxle case with 3 bolts (➡).

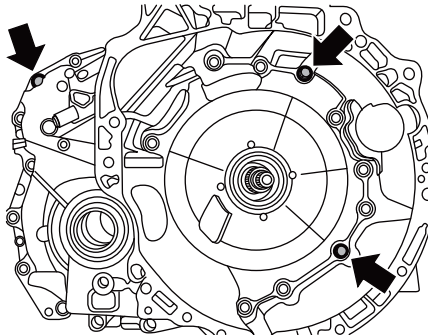

CF100A7IAA00ENG

**CAUTION:**

When fitting the CVT case surfaces, never use the bolts to draw in the case halves. Make sure the case surfaces are flush, and have no gaps prior to installing the bolts.

47. Reposition the CVT assembly on the work bench with the side cover side facing up.

**NOTE:**

- CVT lifter bracket [SST: – (J-51595)] (B) and CVT lifting eye/swivel assembly [SST: – (J-51595-1)] (A) can be used for this step.

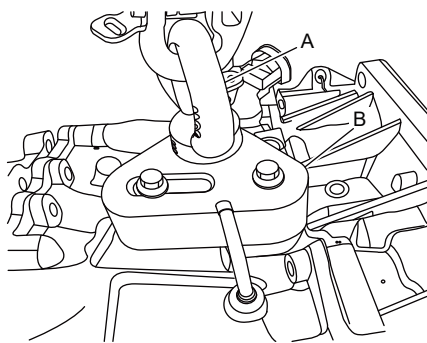

CF100A7JAA00ENG

- Use plastic or wood blocks to stabilize the CVT assembly on the work bench if needed.



**CAUTION:**

- Never hit the manual shaft ① while repositioning the CVT; the manual shaft is longer than the oil pan mating surface.

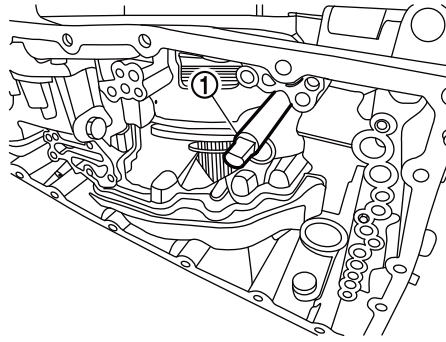

CF100A7KAA00ENG

- Never pinch the terminal connector harness between the transaxle case and work bench or supporting block.

48. Rotate the primary pulley ① by hand to check the pulley's rotational characteristics.

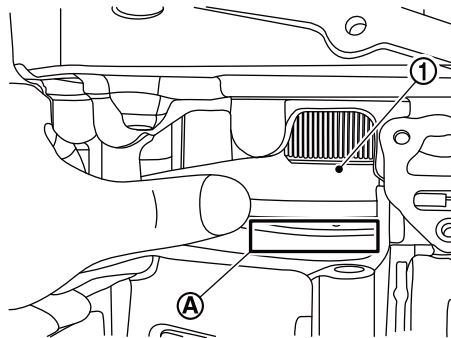

CF100A7LAA00ENG

**CAUTION:**

Never place fingers between the pulley and the transaxle case (A).

**NOTE:**

Remember the pulley's rotational characteristics. This will be used as a reference after the new side cover-pulleys and belt sub-assembly (sub-assembly) have been installed.

49. Remove the side cover fixing bolts.

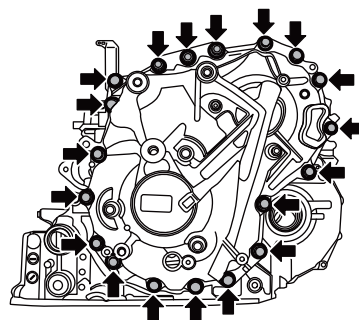

CF100A7MAA00ENG

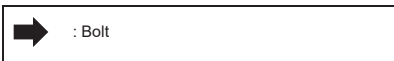

**NOTE:**

When working with sub-assembly install, uninstall, and bracket attachment, it is critical that CVT and sub-assembly are level.

50. Loosen the six retainer bolts so that the clearance between the bolt seating surface and the side cover ① is approximately 5 mm (0.2 inch) (turn the bolts anti-clockwise 360° three times).

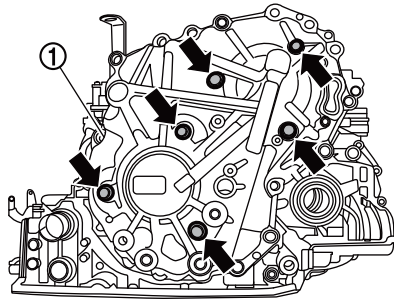

CF100A70AA00ENG

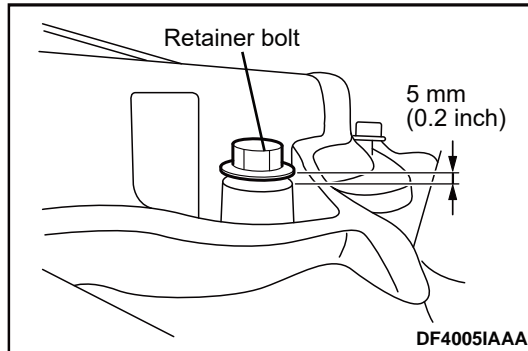

**CAUTION:**

When loosening the retainer bolts (the bolt for fixing the pulley and the side cover) shown in the figure, be careful not to remove the bolts from the side cover.

51. Using special tools, separate the side cover from the transmission case.

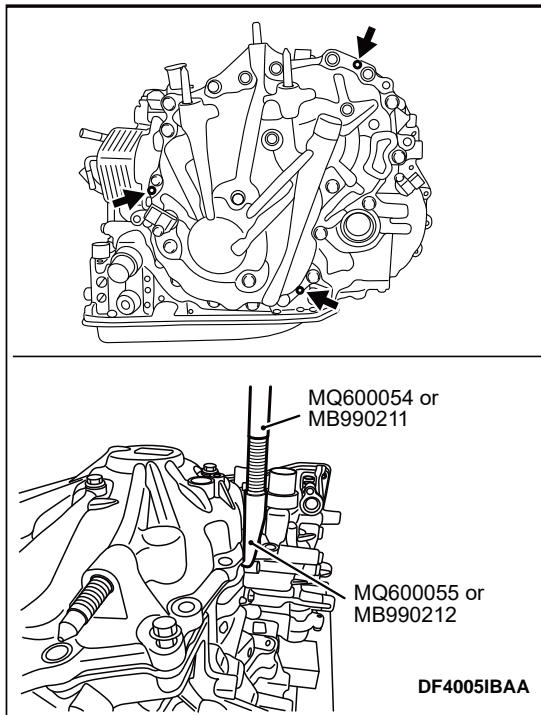

- Slide hammer set (MQ600054) or Slide hammer (MB990211)
- J hook case separator (MQ600055) or Oil seal adapter (MB990212)

**CAUTION:**

- Do not pry between the converter housing and transmission case while separating them.
- Do not use any bars or wedges to separate the side cover and transmission case.

**NOTE:**

Use the special tool at three locations of the side cover shown in the figure (protruded part).

52. Attach the CVT universal lifting fixture [SST: KV315J0100 (J-52082)] (B) with spacers [SST: – (J-52082-2)] (A) to the side cover.

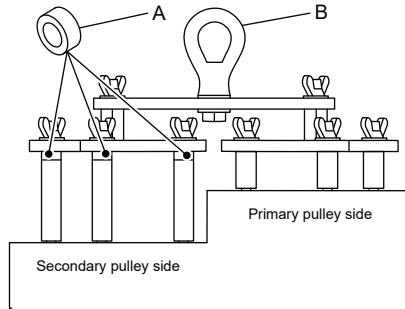

CF100A7NAA00ENG

**NOTE:**

Tighten the wing-nut bolts on the CVT universal lifting fixture [SST: KV315J0100 (J-52082)] finger tight in the following order:

1. Remove one retainer bolt (➡) from the side cover ① and install one bolt of the CVT universal lifting [SST: KV315J0100 (J-52082)] instead and tighten it by hand.

**CAUTION:**

- Do not remove all the retainer bolts (6 bolts) from the side cover simultaneously. If all the retainer bolts are removed simultaneously, the mounting holes of the retainer bolts on the pulley side move from the original positions. Due to this, the bolts of the CVT universal lifting [SST: KV315J0100 (J-52082)] cannot be installed and the belt and the pulley gets separated when the side cover is removed.
- Check that there is no clearance between the mating surfaces of the transmission case and the side cover, and then install the bolts of the CVT universal lifting [SST: KV315J0100 (J-52082)].
- Every time one retainer bolt is removed, be sure to install one bolt of the CVT universal lifting [SST: KV315J0100 (J-52082)].

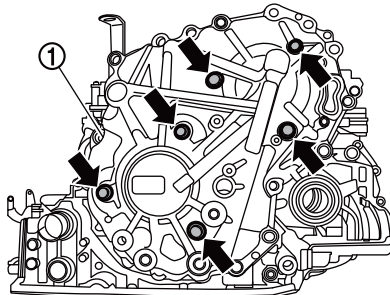

CF100A7OAA00ENG

2. Repeat the same procedure six times.
3. Install spacers [SST: – (J-52082-2)] (A) and CVT universal lifting fixture [SST: KV315J0100 (J-52082)] (B) to shafts.

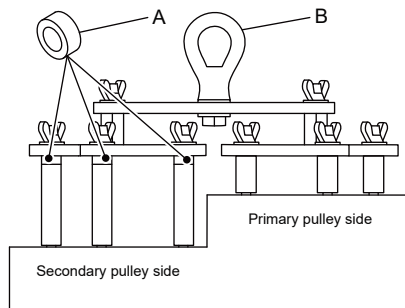

CF100A7NAA00ENG

**CAUTION:**

Install CVT universal lifting (A) properly.

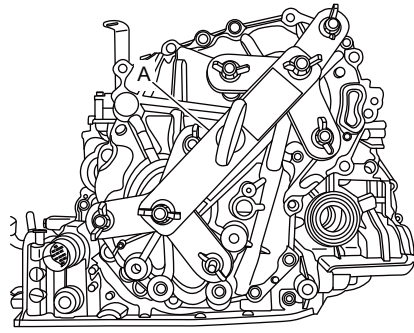

CF100A7QAA00ENG

53. Attach the CVT assembly guide pins [SST: KV315J0200 (J-51959)] (A) as shown in figure.

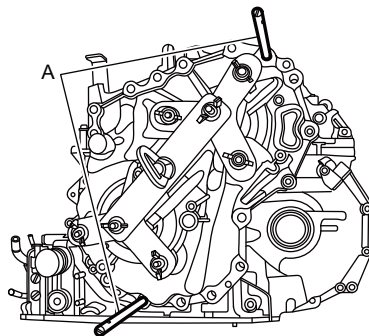

CF100A7RAA00ENG

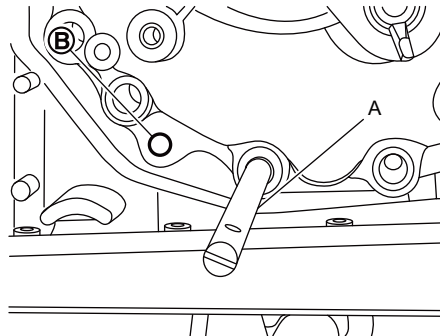

CF100A7SAA00ENG

**CAUTION:**

Guide pins must be placed next to dowel pins (B).



**NOTE:**

Apply rust penetrant to the two dowel pins as needed.

54. Lift up the CVT universal lifting fixture [SST: KV315J0100 (J-52082)] to remove the sub-assembly (1) from the transaxle case.

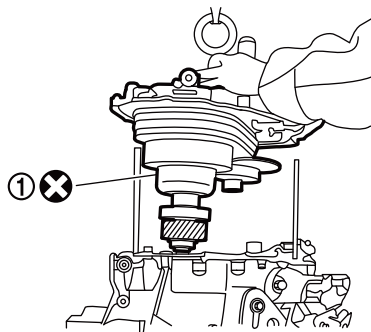

CF100A7UAA00ENG

55. Remove the CVT universal lifting fixture from the sub-assembly.

56. Check the dowel pin remain on the transmission case. If the dowel pin is remained on the side cover side, remove it using a punch with a diameter of 8 mm or less as shown in the figure. When pressing the dowel pin into the hole on the transmission case, perform the following procedures.

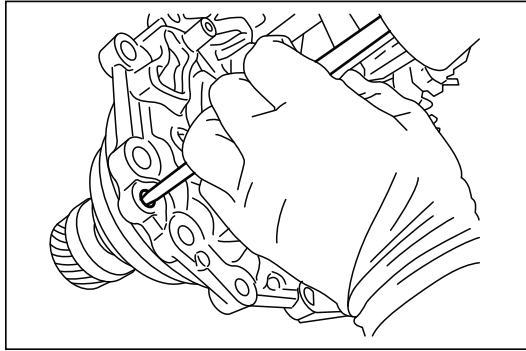

- (1) Stand the dowel pin perpendicular to the hole.
- (2) Press the dowel pin into the hole by lightly hitting it with a hammer.
- (3) Check that the protruding part of the dowel pin is approximately 9 mm (0.4 in).

**CAUTION:**

When removing the dowel pin remained on the side cover side, do not use a tool such as pliers which may damage the surface of the dowel pin.

57. Install all six original bolts into the old sub-assembly.

58. Thoroughly clean the mating surfaces A of the CVT case that the subassembly was just separated from.

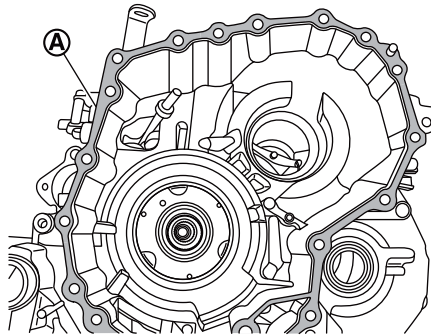

CF100A7VAA00ENG

**CAUTION:**

- Never use sanding discs, similar abrasive tools, or metal blades.
- Use parts cleaner or equivalent solvent and lint-free paper only.
- Make sure the parts cleaner or solvents used are compatible with local regulations.
- Prevent debris from entering in the CVT.
- Make sure rust and debris have been cleaned off of dowel pins and receiving holes.
- Use small wire brush or similar tool at the inside surface of dowel pin holes. Never scrape transaxle case mating surfaces.



**NOTE:**

The CVT assembly guide pins [SST: KV315J0200 (J-51959)] can be temporarily removed for cleaning purposes.

59. Replace the O-ring ①.

**CAUTION:**  
Apply CVT fluid to O-ring.

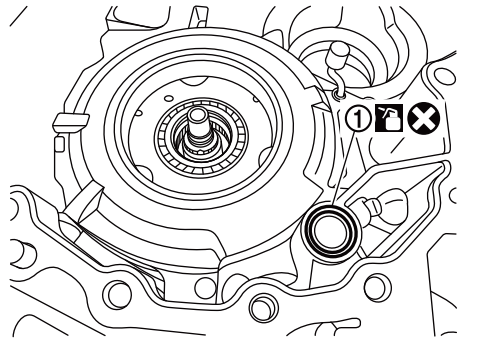

CF100A7WAA00ENG

60. Remove the thrust bearing ① from the planetary carrier assembly.

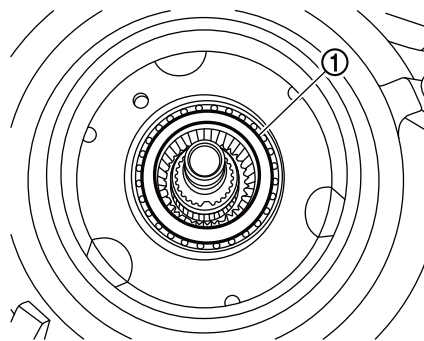

CF100A7XAA00ENG

**NOTE:**  
If not found on the planetary carrier assembly, the thrust bearing may still be attached to the primary pulley.

61. Install the transmission range switch adjustment tool [SST:KV31501600 (J-52508)] (A) to the manual shaft ① and rotate it counterclockwise to adjust the parking rod to the lowest position.

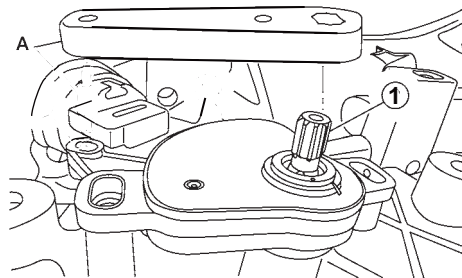

62. Remove the pulley bracket bolts (➡) from the side cover ① of the new subassembly as follows.

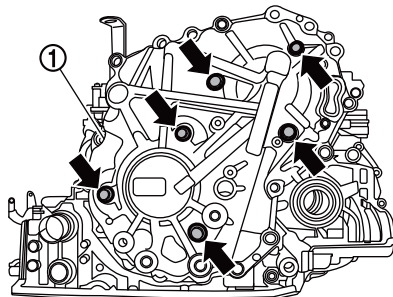

CF100A7OAA00ENG

**CAUTION:**

- Do not remove all the retainer bolts (6 bolts) from the side cover simultaneously. If all the retainer bolts are removed simultaneously, the belt and the pulley are separated and they cannot be returned to the original state.
- Every time one retainer bolt is removed, be sure to install one bolt of the CVT universal lifting fixture [SST: KV315J0100 (J-52082)].

(1) Remove one retainer bolt from the new side cover and install one bolt of the CVT universal lifting fixture [SST: KV315J0100 (J-52082)] instead and tighten it by hand.



**NOTE:**

Install medium (A) and long (B) shafts of CVT universal lifting fixture [SST: KV315J0100 (J-52082)].

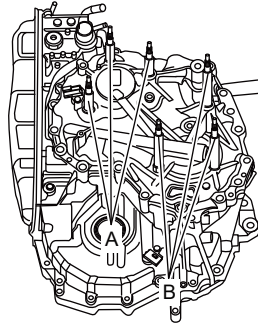

(2) Repeat the same procedure six times.

63. Attach the appropriate CVT universal lifting fixture [SST: KV315J0100 (J-52082)] (A) to the new sub-assembly, and then lift up sub-assembly out of the shipping box.

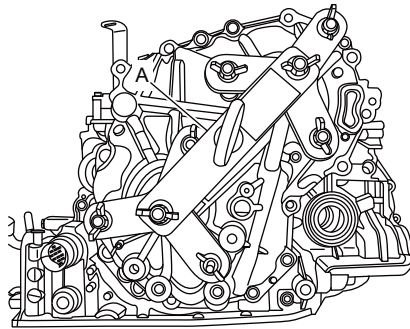

CF100A7QAA00ENG

64. Apply Loctite 5460 on the transaxle case installation surface of the sub-assembly.

**CAUTION:**

- Confirm that the mating surfaces are clean before applying sealant.
- The sealant width is 2.0 mm (0.079 in).
- Check that the starting point and the ending point are about the middle between the bolts. The overlap both ends (A) of the bead by 3 - 5 mm (0.12 - 0.20 in).

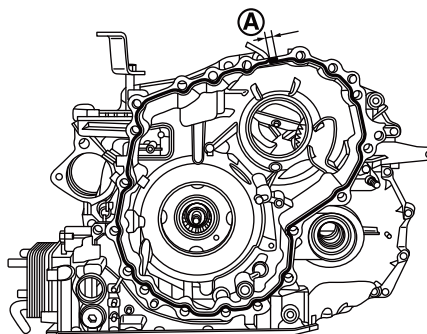

CF100A7ZAA00ENG

- Be careful not to contact or contaminate the sealant. If the sealant has been disturbed or contaminated in any way before case assembly, thoroughly clean the mating surfaces of the transaxle case and re-apply.

65. Install the original thrust bearing ① on the primary pulley ② of the new sub-assembly.

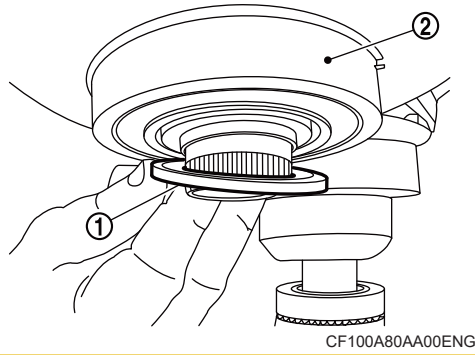

**CAUTION:**

- Pay close attention to the direction of the thrust bearing when installing.

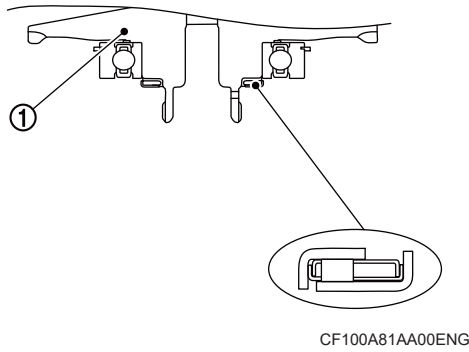

① : Primary pulley

- Apply a small amount of petroleum jelly or equivalent to the original thrust bearing to hold it in place on the primary pulley.

66. Apply CVT fluid to the primary pulley bearing, secondary pulley gear teeth and the secondary bearing when installing the new sub-assembly.

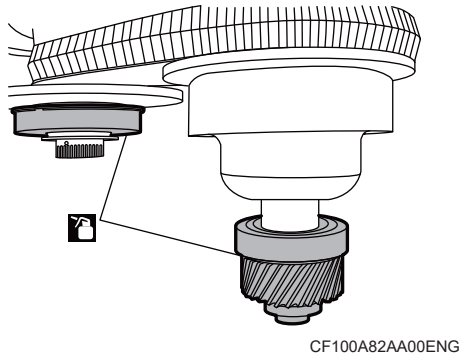

**CAUTION:**

Never drip any CVT fluid onto the sealant.



67. Attach the CVT assembly guide pins [SST: KV315J0200 (J-51959)] (A) to transaxle case when installing the new sub-assembly.

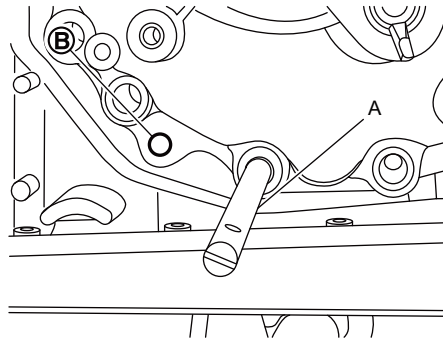

CF100A7SAA00ENG

**CAUTION:**

Guide pins must be installed next to dowel pins (B).

68. Install the new subassembly into the transaxle case as follows.

**CAUTION:**

- Never allow the output gear (1) to hit the lubrication tube (2) when the side cover is positioned over the guide pins.

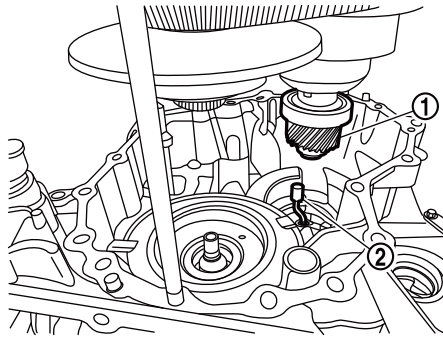

CF100A83AA00ENG

- In the following steps be careful not to contact or contaminate the sealant.
- Never use hammer when installing the new sub-assembly.

(1) Slowly lower the side cover and the belt and pulley assembly until (3) the clearance between the side cover and the belt and pulley assembly and the transmission case is approximately (B) 38 mm (1.50 inch). Then adjust the position of the parking rod using a magnet stick (B) so that the tip of the parking rod (1) locates just below part (A).

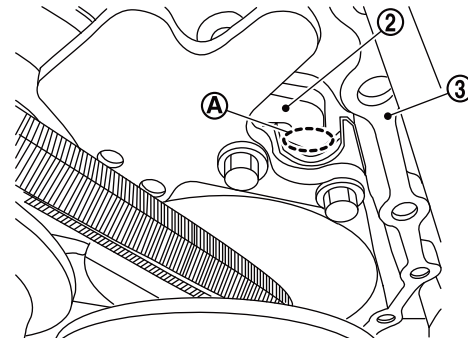
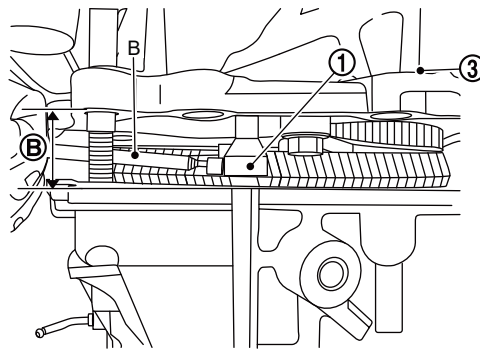

(2) Turn the manual shaft on the transmission case clockwise and set it to "P" range to extend the parking rod, then check that the tip of the parking rod is properly inserted into part (A).

**CAUTION:**

Insert the tip of the parking rod while peeping into part (A).

69. Install the transmission range switch adjustment tool [SST:KV31501600 (J-52508)] (A) to manual shaft (1).

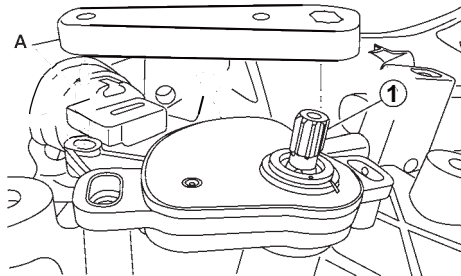

70. Confirm the parking rod operation with the following procedure.

1. Turn the transmission range switch adjustment tool [SST:KV31501600 (J-52508)] (A) clockwise to the P position.
2. Rotate the transmission range switch adjustment tool [SST:KV31501600 (J-52508)] (A) counter clockwise and check that all detents for each of the P-R-N-D are detect.

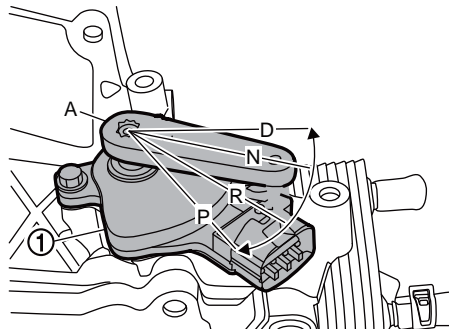

(1) : Transmission range switch

3. Rotate the lever clockwise to return the rod back to the N position.
4. If the lever does not rotate or if all detents are not detect, lift the sub-assembly and remove all sealant, and repeat from step 64.

71. Remove transmission range switch adjustment tool.

72. Remove the CVT assembly guide pins [SST: KV315J0200 (J-51959)].

73. Install the new side cover bolts and temporary tighten them. And then, tighten the bolts to specified torque in the order shown.

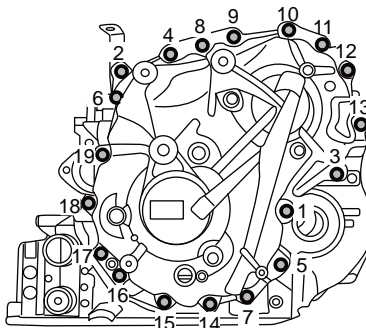

CF100A89AA00ENG

**CAUTION:**

Never reuse the side cover bolts.

74. Remove the CVT universal lifting fixture [SST: KV315J0100 (J-52082)].

**CAUTION:**

Do not remove all the six bolts of the CVT universal lifting fixture [SST: KV315J0100 (J-52082)] from the side cover simultaneously. If all the bolts are removed simultaneously, the mounting holes of the retainer bolts on the pulley side move from the original positions, and the retainer bolts cannot be installed.

- (1) Remove one bolt of the CVT universal lifting fixture [SST: KV315J0100 (J-52082)] from the side cover and install a retainer bolt removed in Step 62 with a new O-ring attached instead. Then temporarily tighten the retainer bolt.

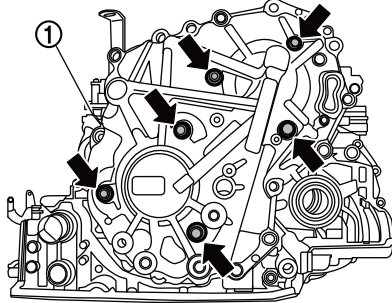

CF100A8AAA00ENG

**CAUTION:**

Never reuse the pulley bracket bolts and the O-rings.

- (2) Repeat the same procedure six times.

75. Check the rotational smoothness of the primary pulley ① with the following procedure.

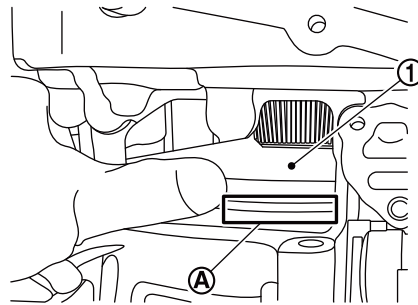

CF100A8BAA00ENG

**CAUTION:**

Never insert fingers between the pulley and the transaxle case ①.

1. With clean hand, access the primary pulley from the bottom of the CVT to rotate.
2. Rotate the primary pulley by hand and confirm that the characteristic is the same as previously checked at step 48.
3. If the rotational characteristic worse than before the sub-assembly was replaced, perform the following.
  - Remove the sub-assembly from the transaxle case.
  - Wipe and clean the sealant completely from both the transaxle case rim and side cover rim.
  - Restart sub-assembly installation from Step 64.

76. Tighten pulley bracket bolts (➡) to the specified torque.

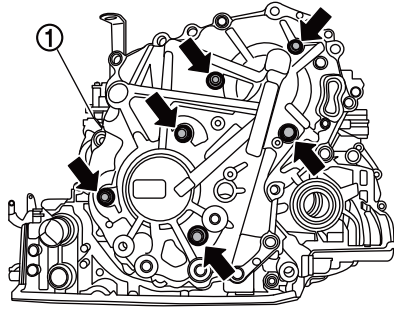

CF100A8AAA00ENG

①	: Side cover
---	--------------

77. Install the differential side oil seal using the output seal installer (case side) [SST: KV31501200 (J-52281)] (A) and universal driver handle [SST: ST35325000 (J-8092)] (B).

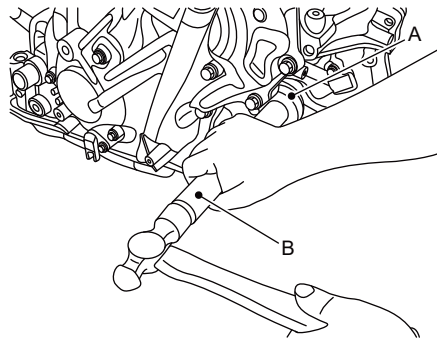

CF100A8CAA00ENG

**CAUTION:**

- Never reuse differential side oil seal.
- Apply CVT fluid to the differential side of oil seal lip surface.

78. Set the CVT on the work bench with the side cover facing down on the bench.

79. Remove the converter housing which was temporarily installed with 3 bolts (➡).

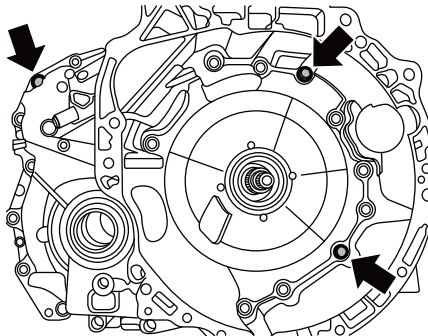

CF100A7IAA00ENG

80. Remove the temporarily attached dummy cover.

81. Calculate total end play with the following procedure. (Thrust bearing selection)

**NOTE:**

The total end play (A) must always be adjusted with thrust bearing ③ between the dummy cover ① and the forward clutch drum ② when a new sub-assembly is installed.

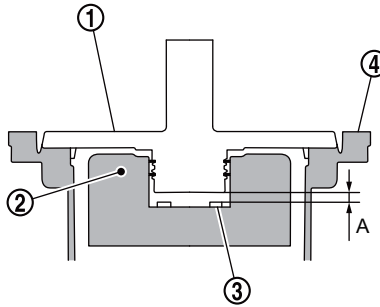

CF100A8DAA00ENG

**CAUTION:**

- The forward clutch is 2 - 3 mm (0.08 - 0.12 in) below the dummy cover surface.
- If the gap is more than 2 - 3 mm (0.08 - 0.12 in), the component parts may be improperly installed. Refer to [Trouble Shooting](#).
- If the gap is less than 2 - 3 mm (0.08 - 0.12 in), the component parts may be missing or damaged.

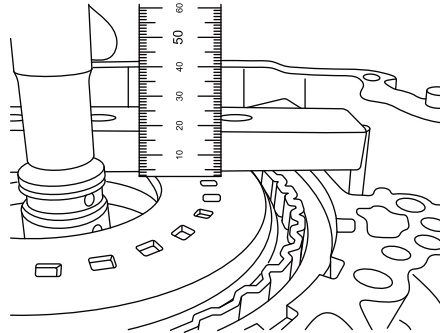

CF100A8EAA00ENG

1. Measure the average distance (D) from the dummy cover installation surface of the transaxle case ① to the thrust bearing installation surface of the forward clutch drum ②.

Average distance (D)	: $(D1 + D2)/2$
A	: Gauge block [SST: KV315J0400 (J-50271)]
B	: Digital depth gauge [SST: KV315J0500 (J-50272)]

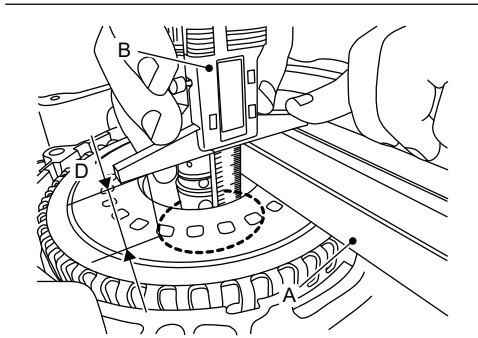
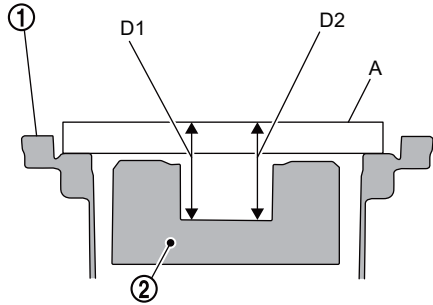

CF100A8FAA00ENG

**CAUTION:**

Never measure from the forward clutch assembly bore in ①.

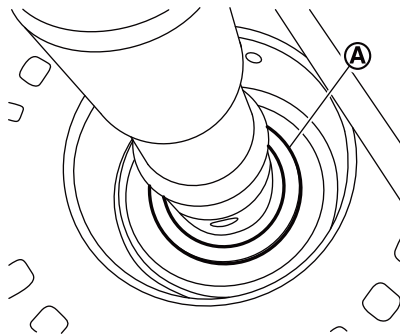

CF100A8GAA00ENG

2. Clean the dummy cover surfaces (A) that contact the transaxle case and thrust bearing.

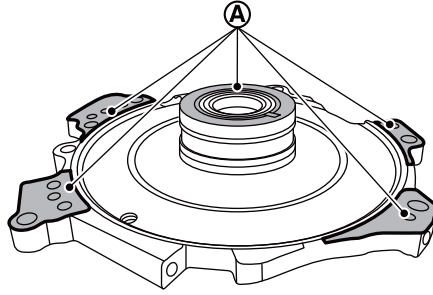

CF100A8HAA00ENG

**CAUTION:**

- Use parts cleaner or equivalent solvent and lint-free paper only.
- Make sure the parts cleaner or solvents used are compatible with local regulations.

3. Using digital depth gauge [SST: KV315J0500 (J-50272)], measure the distance (H) from the edge of the dummy cover (1) to the installation surface on the transaxle case.

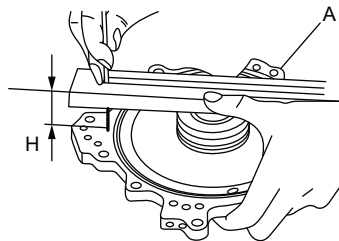
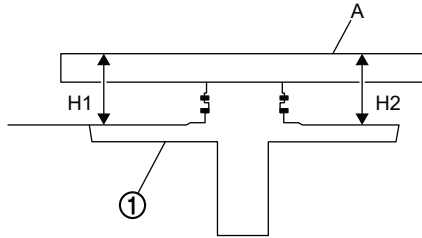

CF100A8IAA00ENG

Average distance (H)	: (H1 + H2)/2
A	: Gauge block [SST: KV315J0400 (J-50271)]

4. Calculate the total end play with the following formula, and choose the appropriate bearing from table.

(D) - (H) = Total end play (A)

Total end play (A)	Bearing thickness	Parts number
3.87 - 4.07 mm (0.1524 - 0.1602 inch)	3.57 mm (0.1406 inch)	2721A028
4.08 - 4.23 mm (0.1606 - 0.1665 inch)	3.75 mm (0.1476 inch)	2721A027
4.24 - 4.43 mm (0.1669 - 0.1744 inch)	3.93 mm (0.1547 inch)	2721A026
4.44 - 4.58 mm (0.1748 - 0.1803 inch)	4.1 mm (0.161 inch)	2721A025
4.59 - 4.78 mm (0.1807 - 0.1882 inch)	4.28 mm (0.1685 inch)	2721A024
4.79 - 4.94 mm (0.1886 - 0.1945 inch)	4.46 mm (0.1756 inch)	2721A023
4.95 - 5.09 mm (0.1949 - 0.2004 inch)	4.61 mm (0.1815 inch)	2721A022
5.10 - 5.29 mm (0.2008 - 0.2083 inch)	4.79 mm (0.1886 inch)	2721A021

82. Install the thrust bearing ① to the clutch assembly bore.

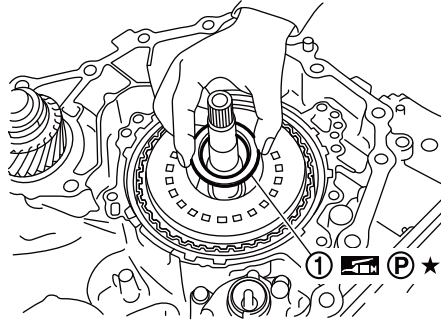

CF100A8JAA00ENG

**CAUTION:**

- Never reuse thrust bearing.
- Apply petroleum jelly when installing the thrust bearing.
- Pay close attention to the direction of the thrust bearing when attaching it.

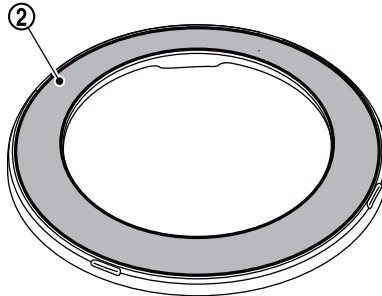
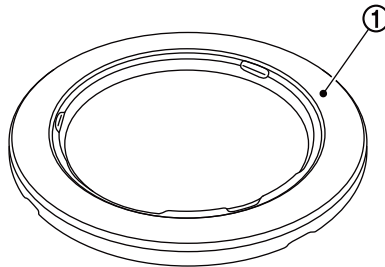

CF100A8KAA00ENG

①	: Upper side
②	: Lower side (Black surface)



83. Remove the baffle plate ① from the converter housing.

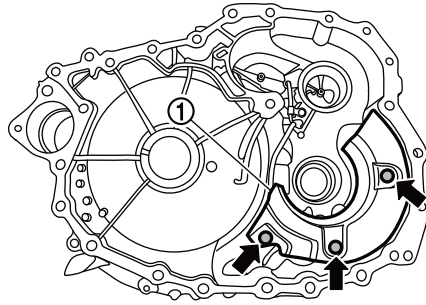

CF100A8LAA00ENG



84. Remove the bolt (➡) and then remove the lubrication tube ① and clip ②.

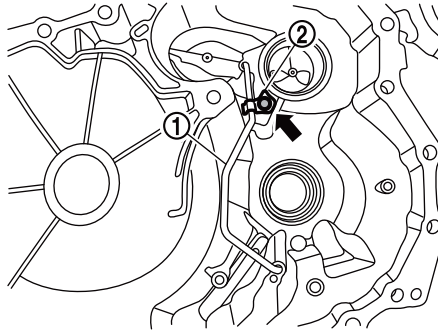

CF100A8MAA00ENG

85. Clean hydraulic circuit (A) of converter housing lubrication tube and dummy cover with parts cleaner and blowing air, check holes (B) for blowing air.

**CAUTION:**

- Never stand in front of the passages shown while using compressed air.
- Wear eye / face protection when using compressed air and cleaning fluids.
- Regulate air pressure up to a maximum of 517 kPa (5.27 kg/cm<sup>2</sup>, 75 psi).

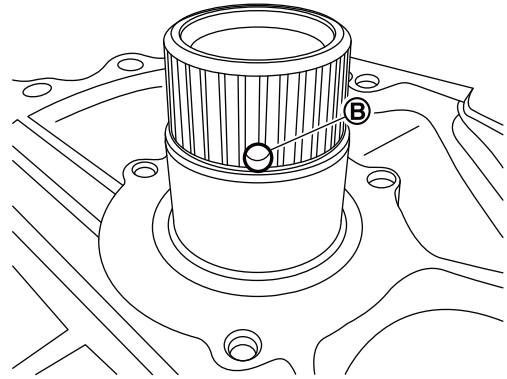
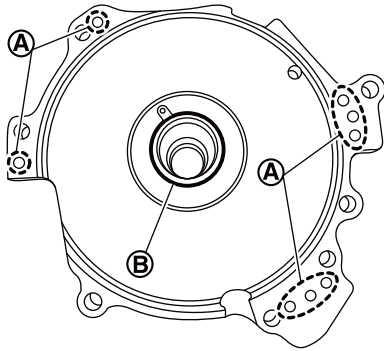
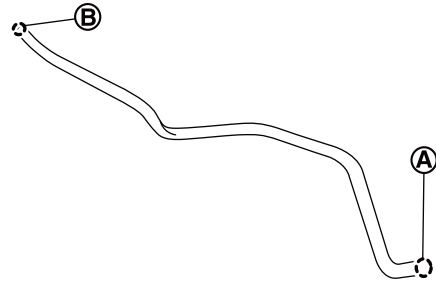
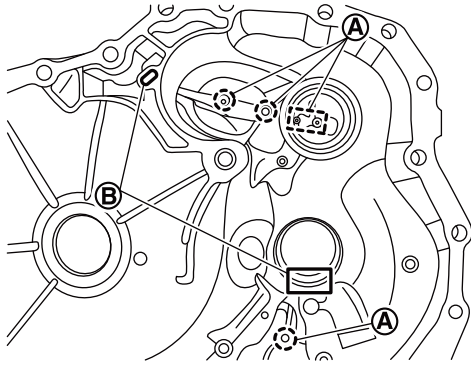

CF100A8NAA00ENG

86. Install the lubrication tube (1) and clip (2).

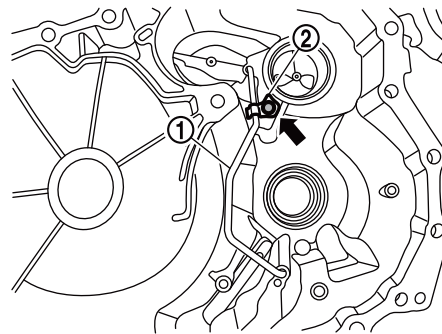

CF100A8MAA00ENG

87. Install the baffle plate ① to the converter housing.

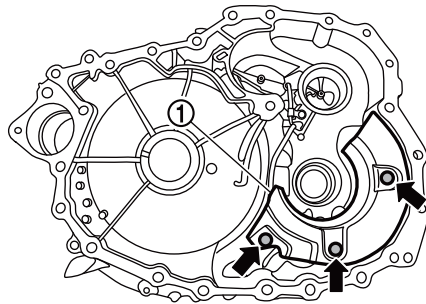

CF100A8LAA00ENG



88. Apply petroleum jelly to the seal rings ① before installing the dummy cover ② to the transaxle case and clean the area ③.

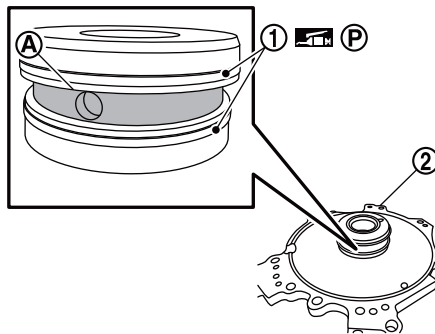

CF100A8OAA00ENG

**CAUTION:**

- Seal rings are in their appropriate slots. Carefully reposition seals as necessary.
- Seal rings must be in their correct positions during final assembly to prevent drivability issues.

89. Check the seal rings ① of input shaft are in the correct positions and clean the area ③.

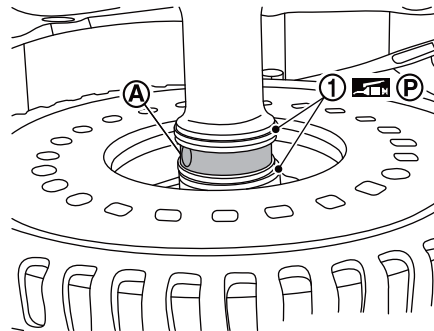

CF100A8PAA00ENG

**CAUTION:**

- Seal rings are in their appropriate slots. Carefully reposition seals as necessary.
- Seal rings must be in their correct positions during final assembly to prevent drivability issues.

90. Install the dummy cover ① and chain guide ②.

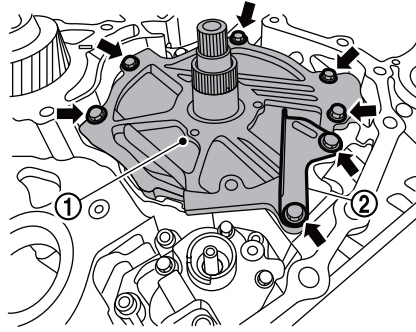

CF100A8QAA00ENG

**CAUTION:**

- Never torque bolts (➡) at this step.
- Check that the dummy cover is fully seated on the transaxle case. If dummy cover does not seated, forward clutch may be improperly installed. Refer to [Trouble Shooting](#).

91. Install the baffle plate B ① and L-bracket ② temporary (tightening by hand), then tighten the bolts. When tightening the L-bracket mounting bolts, tighten the bolts in the order shown in the figure.

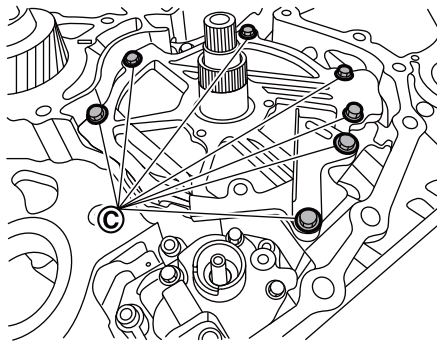
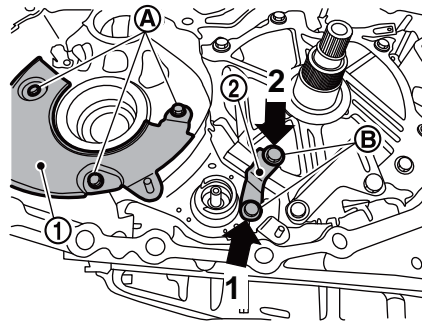

DF100A8RAA00ENG

Ⓐ	: 5.9 N·m (0.6 kg-m, 52 in-lb.)
Ⓑ	: 25.5 N·m (2.6 kg-m, 19 ft-lb.)
Ⓒ	: 19.0 N·m (1.9 kg-m, 14 ft-lb.)

92. Install the thrust washer ① onto the dummy cover ②.

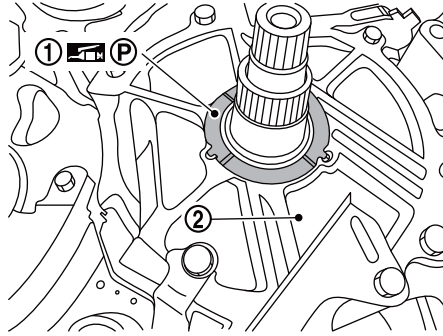

CF100A8SAA00ENG



NOTE:

Use petroleum jelly to hold the thrust washer in place.

93. Install the drive sprocket ①, driven sprocket ②, and oil pump chain ③ as an assembly.

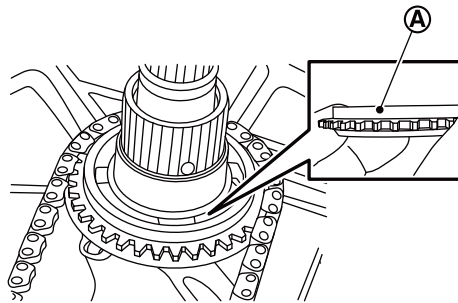
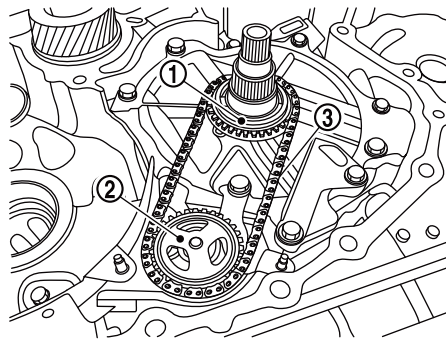

CF100A8TAA00ENG



NOTE:

Wider edge (A) on the drive sprocket is facing up.

94. Spread the snap ring ① using snap ring pliers.

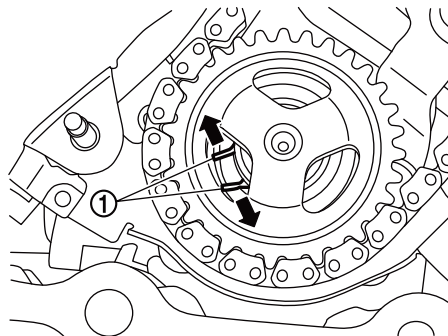

CF100A71AA00ENG

95. Press down on the driven sprocket until it "snaps" and locks into place.

96. Pull up after install sprocket and check lockup to confirm adopt correctly.

97. Install baffle plate (chain cover) ① and tighten the mounting nut.

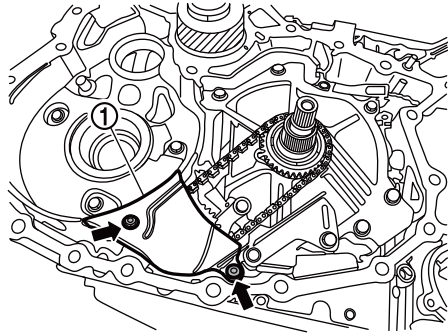

CF100A6ZAA00ENG



98. Install the differential assembly ① into the transaxle case.

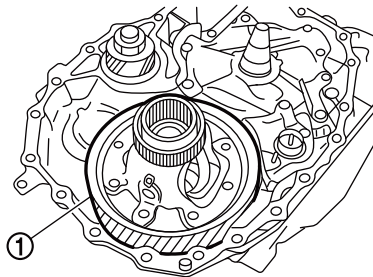

CF100A8UAA00ENG

**CAUTION:**

- Clean differential assembly before installing.
- Apply CVT fluid to the bearings and gear teeth before installing.

99. Install the reduction gear assembly ① into the transaxle case.

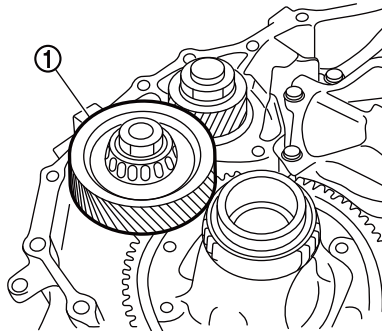

CF100A8VAA00ENG

**CAUTION:**

- Clean reduction gear assembly before installing.
- Apply CVT fluid to the bearings and gear teeth before installing.

100. Install the new CVT fluid filter ① with grommet seal ③ and O-ring ②.

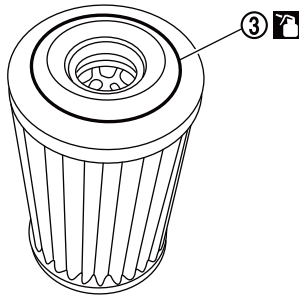
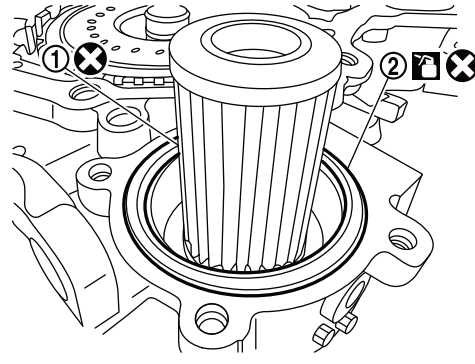

CF100A7CAA00ENG

**CAUTION:**

Apply CVT fluid to the grommet seal and O-ring.

101. Install the CVT fluid filter cover ① and tighten the bolts (➔) to the specified torque.

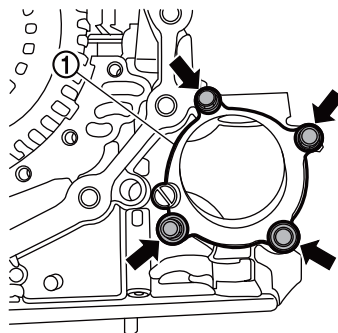

CF100A7BAA00ENG

102. Check that retaining pin of manual shaft ① locates on the original position.

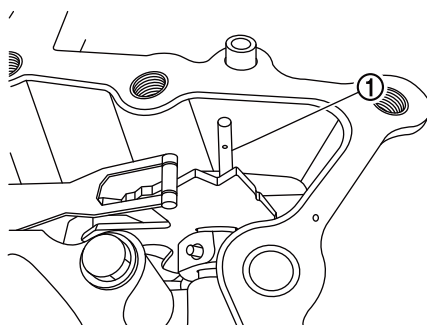

CF100A6TAA00ENG

103. Apply Loctite 5460 on the converter housing installation surface of the transaxle case.

**CAUTION:**

- Completely remove all moisture, oil and old sealant, etc. from the transaxle case and converter housing mounting surfaces.
- The sealant width is 2.0 mm (0.079 in).
- Check that the starting point and the ending point are about the middle between the bolts. The overlap both ends (A) of the bead by 3 - 5 mm (0.12 - 0.20 in).

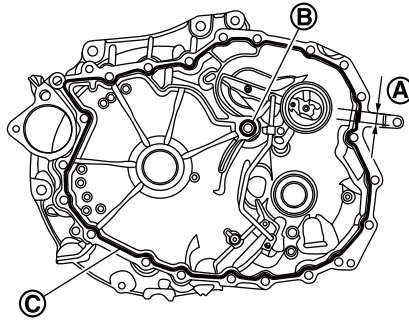

CF100A8WAA00ENG

- Be sure to apply, first sealant around the center bolt hole (B), and next around the mating surfaces (C).

104. Install the converter housing onto the transaxle case and temporary tighten the new converter housing bolts. And then, tighten the bolts to specified torque in the order shown.

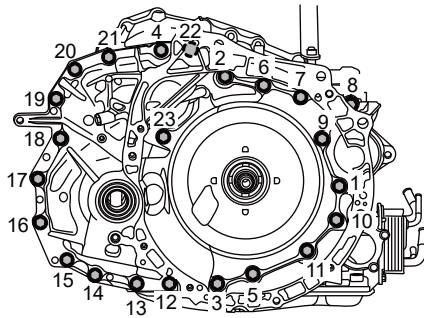

CF100A8XAA00ENG

**CAUTION:**

Never reuse the converter housing bolts.



105. Install the new converter housing oil seal ① evenly using the oil pump seal installer [SST: KV31500700 (J-50818)] (A)

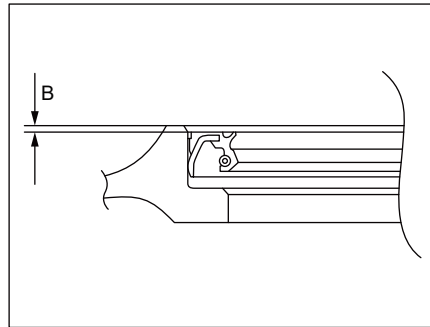
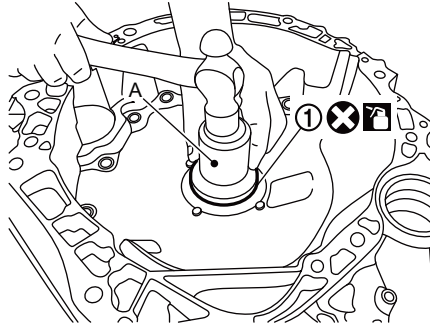

CF100A8YAA00ENG

B : 0.5 mm (0.02 inch)

**CAUTION:**

- Set the torque converter housing flat during installation.
- Apply CVT fluid to the seal lip surface.
- Converter housing oil seal pulling direction is used as the reference.

106. Install the differential side oil seal ① using the output seal installer (torque converter side) [SST: KV31500910 (J-52282)] (A) and universal driver handle [SST: ST35325000 (J-8092)] (B).

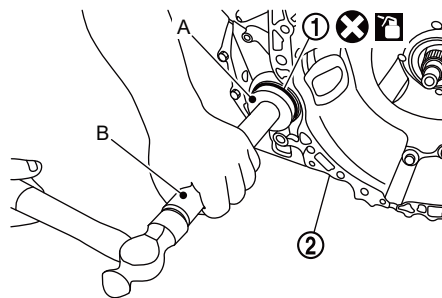

CF100A8ZAA00ENG

② : Converter housing

**CAUTION:**

- Never reuse differential side oil seal.
- Apply CVT fluid to the differential side oil seal lip surface.

107. Install the O-ring ① on the input shaft.

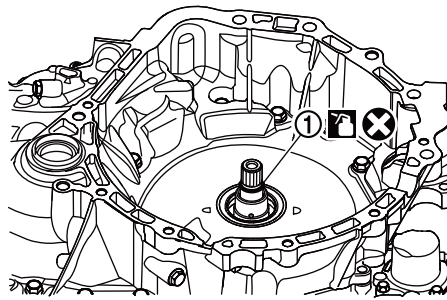

CF100A90AA00ENG

**CAUTION:**

- Never reuse the O-ring.
- Apply the CVT fluid when installing the O-ring.

108. Install the lip seal ① to the transaxle case.

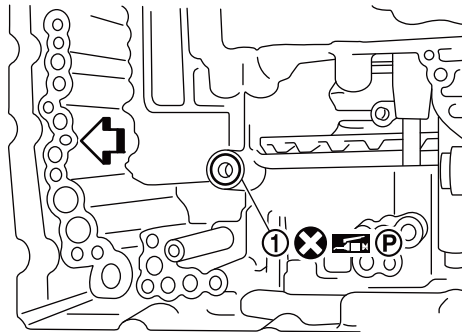

CF100A5TAA00ENG

**CAUTION:**

- Never reuse lip seal.
- Apply petroleum jelly to lip seal.

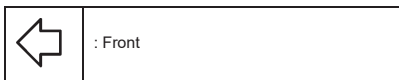

109. Install the control valve to the transaxle case.

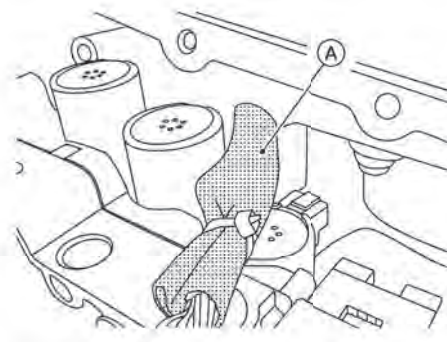

CF100A5UAA00ENG

**CAUTION:**

- Never drop the control valve, manual valve.
- Ensure the harness ① is correctly routed and does not get pinched.

110. Secure the control valve using bolts (A), (B) and (C).

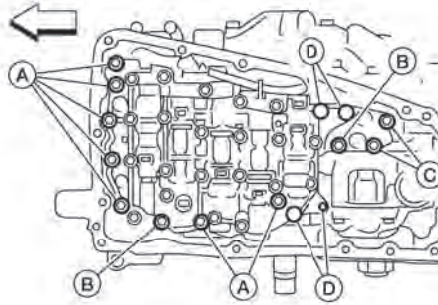

CF100A5VAA00ENG

**CAUTION:**  
Ensure the harness is correctly routed and does not get pinched.

**NOTE:**  
• Leave bolt holes (D) blank at this step.

Bolt	Bolt length mm (in)	Number of bolt
(A)	54 (2.13)	7
(B)	44 (1.73)	2
(C)	25 (0.98)	2



111. Connect the control valve harness connector (A).

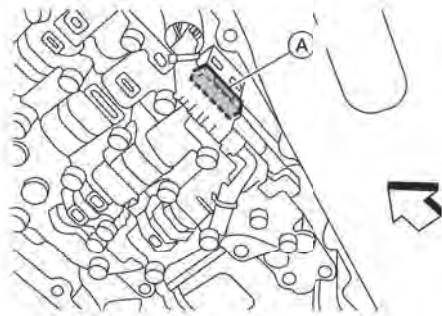

CF100A5WAA00ENG

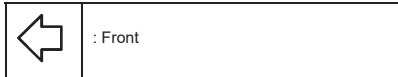

**CAUTION:**  
Securely insert the harness connector until it clicks and locks.

112. Install the CVT fluid temperature sensor bracket to the valve body with bolt (A).

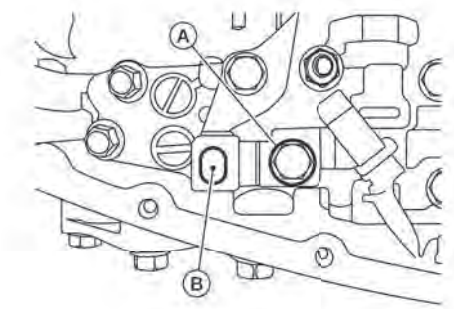

CF100A5XAA00ENG

Bolt	Bolt length mm (in)	Number of bolt
(A)	54 (2.13)	1

**NOTE:**

Leave bolt hole (B) blank as it will be used to secure the oil strainer at a later step.

113. Install new O-ring to oil strainer assembly.

**CAUTION:**

- Never reuse O-ring.
- Apply CVT fluid to O-ring.

**NOTE:**

New oil strainer come with a new O-ring already installed.

114. Install new oil strainer with bolts (A).

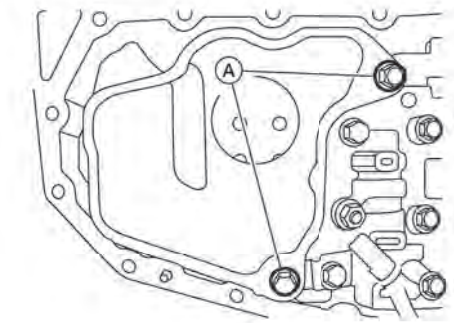

CF100A5PAA00ENG

Bolt	Bolt length mm (in)	Number of bolt
(A)	54 (2.13)	2

115. Install the manual plate ① using the steps below:.

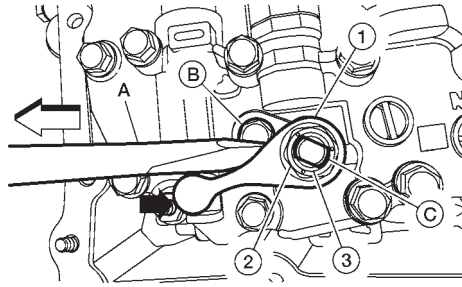

CF100A5YAA00ENG

- Align the slot of the manual plate with the manual shaft ③.
- Align the end of the manual plate with the cutout (←) of the manual valve.

**CAUTION:**

Install the end of the manual plate into the cutout of the manual valve.

- Install spring washer ② and lock nut ③.
- Insert suitable tool (A) between manual plate and bolt ② and tighten lock nut.

**CAUTION:**

Using suitable tool, be sure to hold the manual plate in a fixed position. Be sure not to damage control valve while using suitable tool.

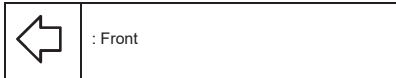

116. Install the spring washer ② and the lock-nut ③, and then tighten to the specified torque.

**CAUTION:**

To tighten nut, fix manual plate with suitable tool.

117. Install the magnets into the oil pan in their original location.

**CAUTION:**

Completely clean the iron powder from the magnet area of oil pan and the magnet.

118. Install the oil pan to the transaxle case with the following procedure.

- (1) Install the oil pan gasket to the oil pan.

**CAUTION:**

- Completely wipe out any moisture, oil, and old gasket from the oil pan gasket surface and bolt hole of oil pan and transaxle case.
- Never reuse oil pan gasket.

- (2) Temporarily attach the oil pan assembly to the transaxle case using the oil pan bolt with transmission fluid applied to the threads and seat surface.

**CAUTION:**

Do not allow the transmission fluid to drip inside the CVT.

(3) Tighten the oil pan bolts in the order shown to the specified torque.

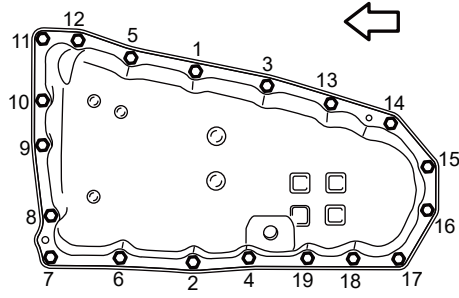

CF100A5LAA00ENG



(4) Tighten the oil pan bolts again clockwise from (1) shown to the specified torque.

119. Install drain plug gasket to drain plug.

**CAUTION:**  
Never reuse drain plug gasket.

120. After installing the drain plug, place the CVT with the oil pan side down.

121. Apply grease evenly to the shift actuator spline (A).

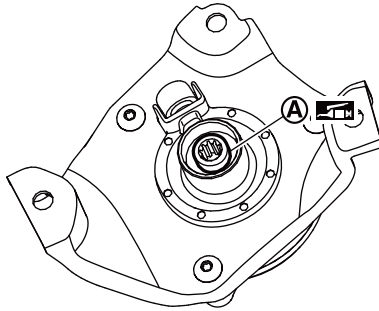

CF100A5GAA00ENG

122. Install the shift actuator to the transaxle case.

123. Tighten bolts (A).

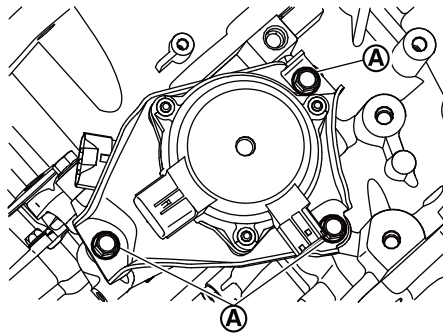

CF100A5FAA00ENG

124. Install new QR code sticker ① on shift actuator ②.

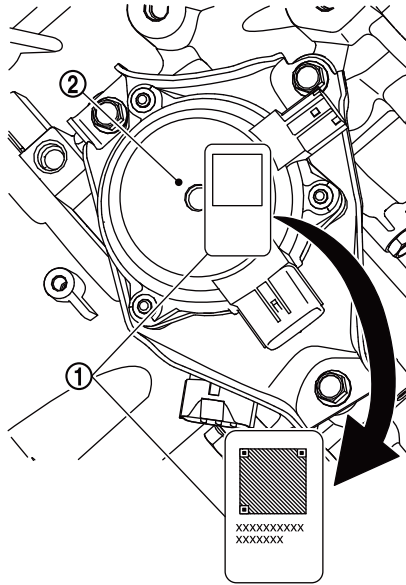

CF100A5ZAA00ENG



**NOTE:**

If sticker is not included with parts, contact Powertrain Call Center to report.

125. Install the torque converter ① to the transaxle in the following procedure.

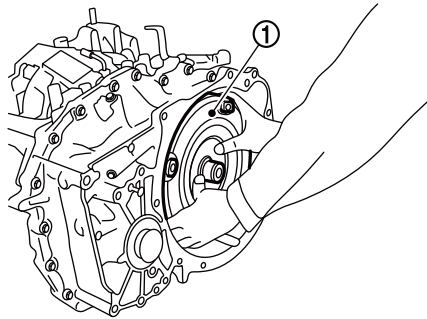

CF100A6OAA00ENG

1. Insert the pawl (A) of the torque converter to the drive sprocket hole (B) on the transaxle assembly side.

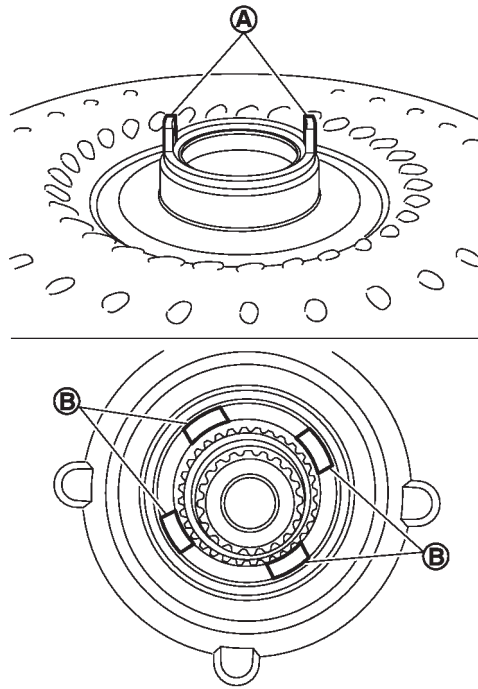

CF100A91AA00ENG

**CAUTION:**

- Rotate the torque converter for installing torque converter.
- Never damage the bushing inside the torque converter sleeve when installing the converter housing oil seal.

2. After inserting a torque converter to the CVT, check dimension (A) with in the reference value limit.

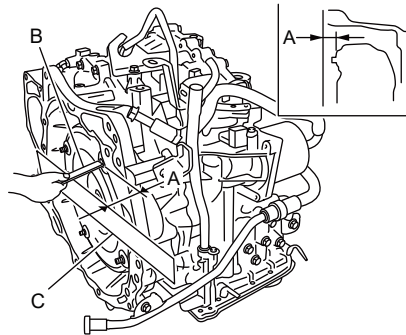

CF100A6FAA00ENG

B	: Scale
C	: Straightedge
Dimension (A)	14.4 mm (0.567 inch)

126. Install the primary speed sensor.

**CAUTION:**

- Never reuse O-ring.
- Apply CVT fluid to the O-ring.

127. Install the transaxle assembly to the vehicle.

128. Flush the CVT fluid cooler and lines.

129. Fill the transaxle assembly with CVT fluid.

130. Perform "ADDITIONAL SERVICE WHEN REPLACING CONTROL VALVE."



Trouble Shooting

The Dummy Cover Will Not Sit Flush

**NOTE:**

- If the dummy cover does not sit flush, the forward clutch assembly may not be fully seated. The forward clutch assembly is not fully seated if it is not below the surface that the dummy cover bolts to.

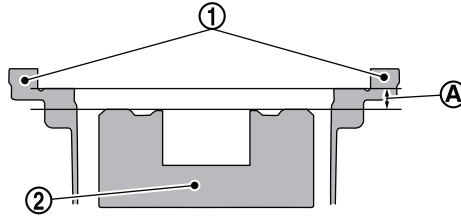

CF100A92AA00ENG

①	: Transaxle case
②	: Forward clutch assembly
A	: The clearance between the dummy cover and the forward clutch assembly

- Always handle the forward clutch assembly by the input shaft.

1. Remove the dummy cover ①.

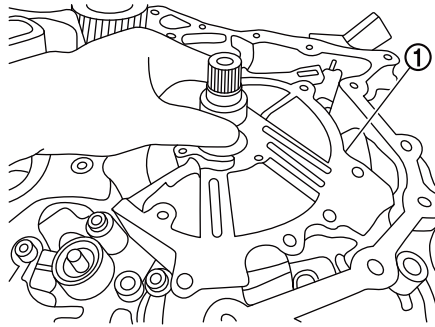

CF100A93AA00ENG

2. Pull up the forward clutch assembly ② by the input shaft ① to remove the entire forward clutch assembly.

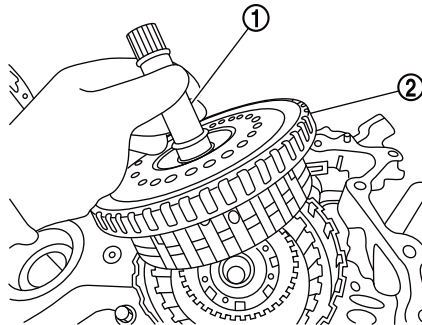

CF100A94AA00ENG

3. Using a suitable tool (A) gently align the layers ① of the forward clutch assembly ②.

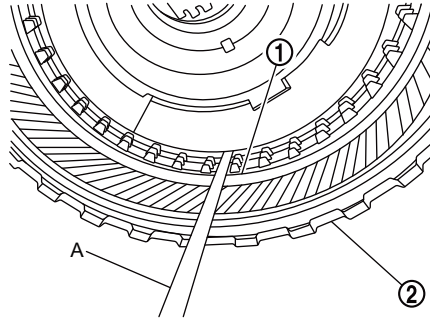

CF100A95AA00ENG

4. Re-insert the entire forward clutch assembly ② while holding the input shaft ①.

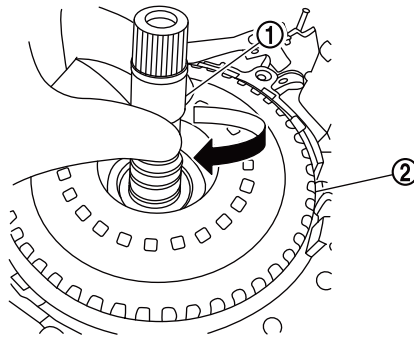

CF100A96AA00ENG

**NOTE:**

- Gently jiggle the input shaft until the forward clutch assembly seats below case lip.
- If the forward clutch assembly does not seat, rotate back and forth from the input shaft and jiggle.
- If the clutch pack still does not seat, repeat from step 3.