

APB2 – Checking High-Volt Battery and Replacing if Necessary (Stop Delivery / Recall Campaign)

Revision: This bulletin replaces bulletin Group 2 152/23 APB2, dated December 6, 2023.

Model Year: **As of 2020 up to 2023**

Model Line: **Taycan (Y1A / Y1B / Y1C)**

Concerns: **High-volt battery**

Cause: **It could happen that under certain circumstances the seal between the battery casing and battery cover on the high-volt battery on the affected vehicles is not sufficiently robust and does not, therefore, reliably seal over the lifetime of the vehicle.**

In the case of an insufficiently robust seal, under certain circumstances, liquid could penetrate inside the high-volt battery over time.

If a conductive liquid entering the battery exceeds a certain limit value, the insulating resistance decreases. If the insulating resistance falls below a defined limit value over time, a yellow warning message is displayed in the vehicle.

If the insulating resistance continues to fall below a defined limit value in the course of time, a red warning message is displayed in the vehicle.

If customers do not contact a Porsche Center despite a red warning message in the vehicle, and a sufficient amount of conductive liquid has accumulated in the high-volt battery, electric arcs could build up that could heighten the risk of a thermal event.

Action: Check high-volt battery and replace it depending on the test result.



Information

Every vehicle is assigned **exactly one** campaign scope.

⇒ To find out which scope is assigned to the relevant vehicle, see PCSS Vehicle Information.

Affected Vehicles: Only vehicles assigned to the campaign (see also PCSS Vehicle Information).

Required parts



Information

A new pressure release valve must only be installed if the high-voltage battery is not replaced.

If a new high-voltage battery is installed as part of this campaign, it is not necessary to replace the pressure release valve.

Parts Info:

Part No.	Designation – Location	Number
V04015007AP	⇒ Pressure valve	1 piece
N 10700201	⇒ Internal hexagon round-head bolt – Pressure valve	4 pieces
Additional parts required for vehicles with PDCC (M-No. 1P7):		
N 91006202	⇒ Hexagon-head bolt – Anti-roll bar PDCC, front	4 pieces

Required tools

Tools:

- **T40262 - Locking cap**
- **VAS 6558A - High-voltage testing module**
- **VAS 6558A - /9-6A high-voltage test adapter**
- **VAS 6883A - Insulated tool set**
- **VAS 5581A - Diagnostic Box**
- **VAS 6884 - High-voltage cordon**
- **VAS 6911/3B - Test plug set**
- **9925 - Leak-tightness test set**
- **9925/1 - Adapter cable**
- **V.A.G 1274B - Cooling system tester**
- **V.A.G 1397B - Pressure sensor**
- **P90999 - P90999 - PIWIS Tester 4** with PIWIS Tester test software release 42.250.030 (or higher)
- Battery charger with a current rating of at least 90 A, e.g. **VAS 5908 - battery charger 90 A**
- **VAS 6931 - Transmission and gearbox jack**
- Torque wrench, 2-10 Nm (1.5-7.5 ftlb.), e.g. **V.A.G 1783 - torque wrench, 2-10 Nm (1.5-7.5 ftlb.)**
- Torque wrench, 6-50 Nm (4.5-37 ftlb.), e.g. **V.A.G 1331A - torque wrench, 6-50 Nm (4.5-37 ftlb.)**



Information

Auto-ship WNW3 campaign tool

Special test adapters (one adapter plate and one adapter plug each) are required to check the high-voltage battery for leaks.

One **PNAWNW3KIT** kit will be auto-shipped to every dealer and service center by PCNA. Additional kits are available to order through Polaris.

Required test adapter - Set:

- **Adapter plate**



Adapter plate

- **Adapter plug**



Adapter plug

Preliminary work



WARNING

Incorrect handling of high-voltage components

- Electric shock
 - Short circuit
 - Fire
 - Explosion
- ⇒ Only appropriately trained and authorized persons are permitted to work on high-voltage vehicles and components.
- ⇒ Required qualification: High voltage technician or high voltage expert.
- ⇒ Observe national requirements and legislation for this work.
- ⇒ Always use insulated tools, e.g. VAS 6883 Insulated Tool Set when working on these components.
- ⇒ Observe general warning notes for working on the high-voltage system. ⇒ *Workshop Manual '2X00IN General warning notes for working on the high-voltage system'*

- Work Procedure: 1 Observe general warning notices for working on the high-voltage system.
⇒ *Workshop Manual '2X00IN General warning notes for working on the high-voltage system'*
- 2 Classify lithium-ion battery.
⇒ *Workshop Manual '2X00IN Classification of lithium-ion battery'*
- 3 Open the door-window on the driver's side. Open vehicle front flap and rear luggage compartment and secure against unintentional closing.
- 4 Isolate the high-voltage system from the power supply.
⇒ *Workshop Manual '2X00IN Activate/Start high-voltage system'*
- 5 Remove (center) luggage compartment trim panel luggage compartment cover.
⇒ *Workshop Manual '70061900 Remove and install (centre) luggage compartment trim panel (luggage compartment cover)'*
- 6 Remove insulating mat.
- 6.1 Loosen plastic clips at the corners of the insulating mat.
- 6.2 Remove insulating mat.

Checking high-volt battery

Work Procedure: 1 Lift up body cover ⇒ *Removing body cover-1-* in the luggage compartment to allow access to the high-voltage line for the electric machine at the rear using a plastic wedge and remove it.

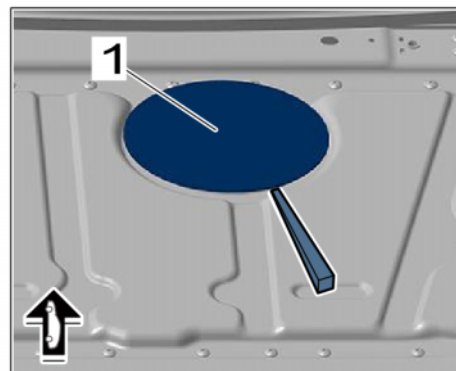

Removing body cover

2 Unscrew screws ⇒ *High-voltage line for rear electric machine-1-* for high-voltage line connection for electric machine at the rear and disconnect electric plug connection from electric machine at the rear.

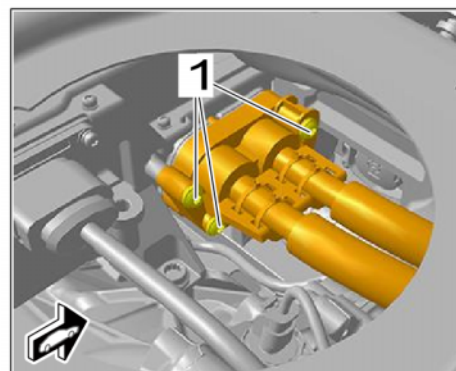

High-voltage line for rear electric machine

3 Remove Styrofoam element ⇒ *Removing Styrofoam element-1-*.

3.1 Undo clips ⇒ *Removing Styrofoam element-2-*.

3.2 Carefully pull Styrofoam element ⇒ *Removing Styrofoam element-1-* upwards.

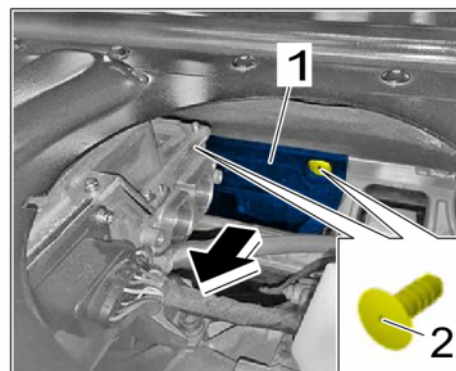

Removing Styrofoam element



Information

The pressure release valve and fastening screws cannot be reused and must be replaced.

Before assembling the adapter plate (before the pressure test) and before assembling the pressure valve (after performing the pressure test), the frame of the high-voltage battery must be cleaned with isopropanol in the contact surface area of the seal.



Pressure valve

- 4 Remove pressure valve ⇒ *Pressure valve -2-*.
 - 4.1 Unscrew screws ⇒ *Pressure valve -1-*.
 - 4.2 Disconnect pressure valve ⇒ *Pressure valve -2-*.

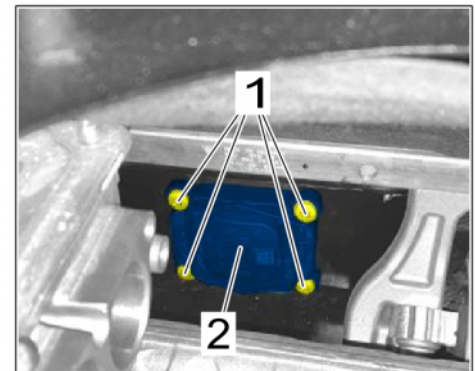

Pressure valve

- 5 Install adapter plate ⇒ *Adapter plate on high-volt battery -2-*.
 - 5.1 Clean sealing surface on high-volt battery with isopropanol.
 - 5.2 Attach adapter plate ⇒ *Adapter plate on high-volt battery -2-*.
 - 5.3 Screw in screws ⇒ *Adapter plate on high-volt battery -1-* and tighten with **tightening torque 8 Nm (5.9 ftlb.)**.

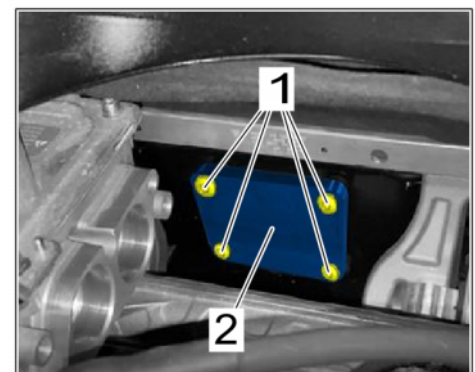

Adapter plate on high-volt battery

- 6 Connect adapter plug ⇒ *Adapter plug on high-voltage line-2-*.
 - 6.1 Connect adapter plug ⇒ *Adapter plug on high-voltage line-2-* to high-voltage line.
 - 6.2 Screw in screws ⇒ *Adapter plug on high-voltage line-1-* by hand.

- 7 Remove front axle support (rear section).
⇒ *Workshop Manual '400819 Removing and installing front axle support (rear section)'*

- 8 For vehicles with PDCC, release front anti-roll bar and secure it in place at a suitable position with tie-wraps. The front anti-roll bar coupling rods do not need to be loosened. For instructions, see: ⇒ *Workshop Manual '407709 Loosening and securing front anti-roll bar (PDCC)'*

- 9 Unclip coolant pipes ⇒ *Loosening coolant pipes-1-* from bracket ⇒ *Loosening coolant pipes-2-* and ⇒ *Loosening coolant pipes-Arrow-* slide them to the side.

- 10 Disconnect the high-voltage line (high-voltage distributor to the high-volt battery) on the high-volt battery. Release ⇒ *Disconnecting the high-voltage line at the high-volt battery-A-*, open ⇒ *Disconnecting the high-voltage line at the high-volt battery-B-* and disconnect ⇒ *Disconnecting the high-voltage line at the high-volt battery-C-*.

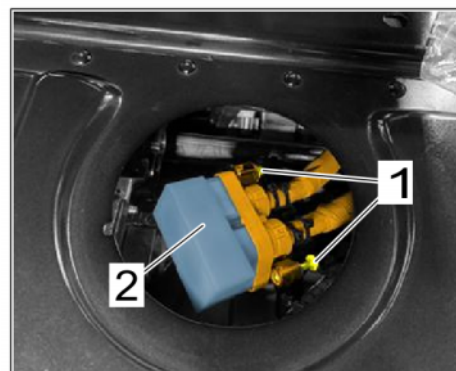

Adapter plug on high-voltage line

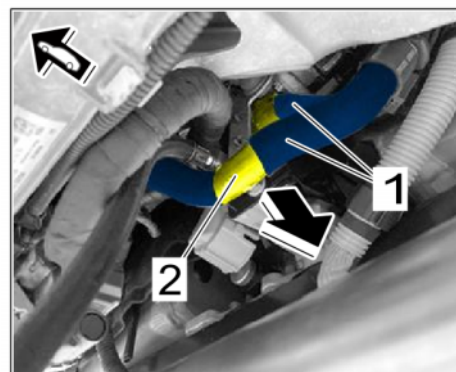

Loosening coolant pipes

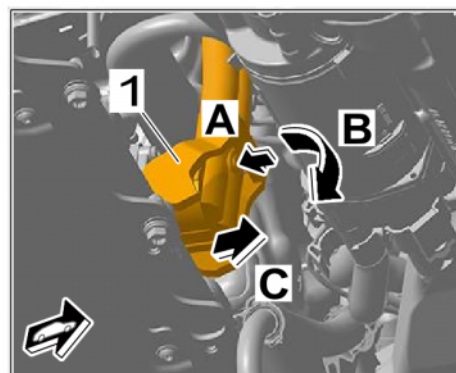

Disconnecting the high-voltage line at the high-volt battery

- 11 ⇒ *Electric plug connection E-box-1*- Release ⇒ *Electric plug connection E-box -Arrow-* electric plug connection for E-box and disconnect.

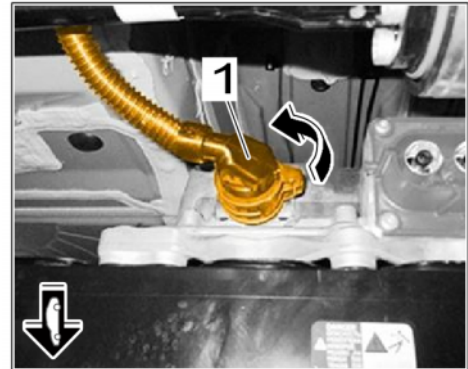

Electric plug connection E-box

- 12 Attach test connector and adapter plug from **9925 - leak test set** to CAN line connection ⇒ *Test plug and adapter plug-1-* and high-voltage connection for front E-box ⇒ *Test plug and adapter plug-2-*.
- 13 **9925 - Leak test set, cooling system tester, 9925/1 - adapter cable, hose connector, measurement and test equipment for PIWIS Tester 4** and **P90999 - P90999 - PIWIS Tester 4** must be set up.

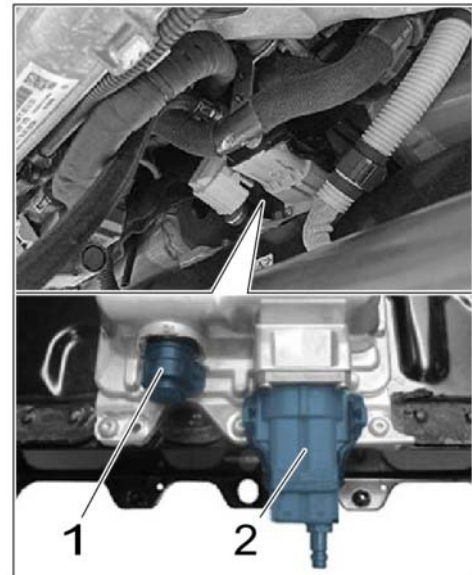

Test plug and adapter plug

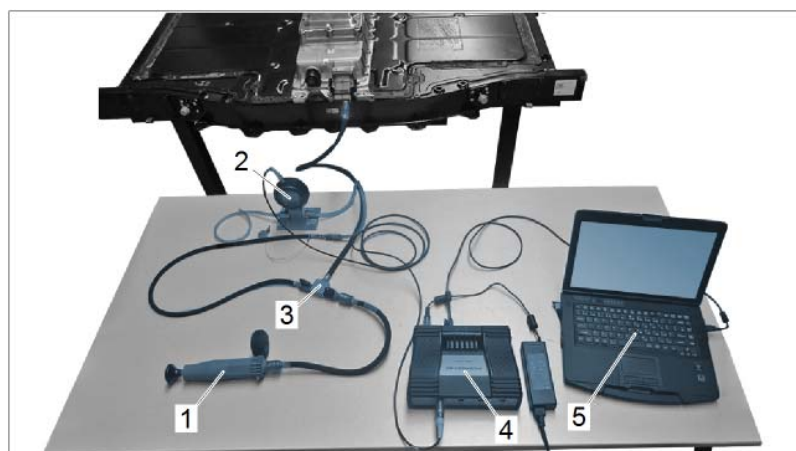

Battery housing leak test set-up

- 1 – Hand pump
- 2 – Pressure sensor
- 3 – Valve block
- 4 – Measurement and test equipment for PIWIS Tester
- 5 – PIWIS Tester



Information

PIWIS Tester test software release **42.250.030** (or higher) required to perform the pressure test. With older software versions, the test parameters of the PIWIS Tester do not meet the specifications.



Information

Please use only the VAG 1274B hand pump to pressurize the system to a start pressure of 25 mbar as prompted in the Taycan Measuring System Parameter set. Use of another pump or higher pressures outside the tolerance can cause permanent deformation of the battery housing.



Information

Please note that the pressure test described in ⇒ *Workshop Manual '270803 leak tests on the high-voltage battery'* refers to a removed battery.

However, the pressure test must be carried out explicitly in the vehicle with a installed battery.

- 14 Perform leak test on the battery housing.
For instructions, see: ⇒ *Workshop Manual '270803 Carrying out leak tests on high-volt battery'*

Assessment		Action
(✓)	Leak test OK (pressure drop less than 0.6 mbar according to the protocol)	Continue with Step 18.
(x)	Leak test not OK (Pressure drop value not OK) (pressure drop is 0.6 mbar or more)	Repeat leak test. Continue with Step 15.

Result protocol	
Leaktightness test: Battery casing	
Software	
Test software	Measuring system
Version	4.0.2
Operator	
Operator	
Vehicle	
Vehicle identification number	
Parameter	
Parameter set	Y1A
Start pressure	mbar 25.0
Tolerance start pressure (+)	mbar 5.0
Tolerance start pressure (-)	mbar 5.0
Abort threshold	mbar 1.000 0
Differential pressure cool-down	mbar 1.5
Differential pressure increase	mbar 1.5
Measurement differential pressure	mbar 0.7
Cool-down period	s 60
Measurement time	s 600
Measuring values	
Result	
Total results	The system is leaktight
Measurement	
Slowdown pressure	mbar 28.9
Slowdown pressure minimum	mbar 27.4
Start pressure	mbar 28.8
Measuring pressure minimum	mbar 28.1
End pressure	mbar 29.6
Pressure drop	mbar 0.5
Preload time	s 60
Cool-down period	s 60
Measurement time	s 600

Test log

- 15 Save test report, print it out and attach it to the PCSS process line.
- 16 Make sure that the failed pressure test is not caused by a leak in the measuring equipment.
To do this, proceed as follows:
 - Check all connecting elements, connection points, couplings and the hand pump for leaks using a leak detection spray.
 - If a leak is detected, replace the affected tool and repeat the pressure test.
- 17 Repeat leak test of the battery housing.
For instructions, see: ⇒ *Workshop Manual '270803 Carrying out leak tests on high-volt battery'*

Assessment		Action
(✓)	Repeat test OK (pressure drop less than 0.6 mbar according to the protocol)	Continue with Step 18.
(x)	Repeat test not OK Pressure drop value not OK (pressure drop is 0.6 mbar or more)	Replace high-volt battery. Continue with: ⇒ <i>Technical Information '270803 Replacing high-volt battery'</i>

- 18 Save test report, print it out and attach it to the PCSS process line.
- 19 Remove test equipment for leak test.
- 20 Remove test plug and adapter plug from the box CAN line connection ⇒ *Test plug and adapter plug-1-* and front E-box high-voltage connection ⇒ *Test plug and adapter plug-2-*.

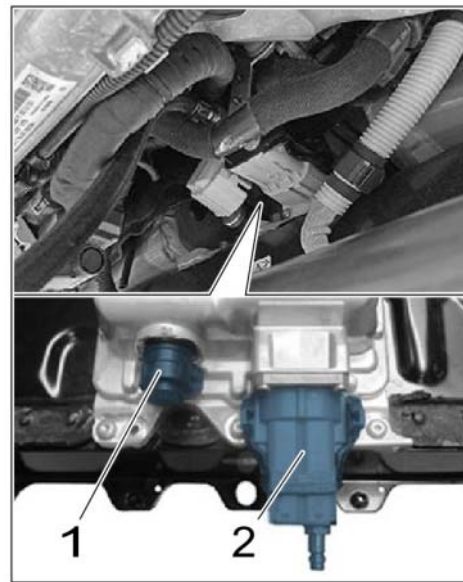

Test plug and adapter plug

- 21 Connect E-box electric plug connections ⇒ *Electric plug connection E-box-1-* and lock them.
- 22 Connect high-voltage line (high-voltage distributor to high-volt battery) to the high-volt battery and lock it.

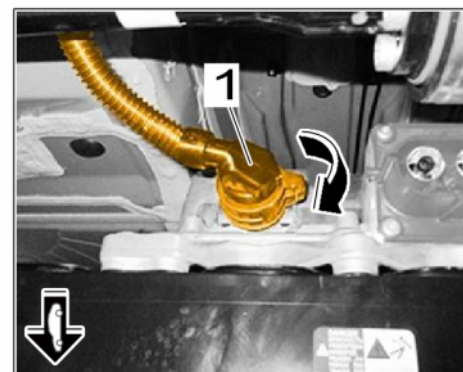

Electric plug connection E-box

The electric plug connection must engage perceptibly.

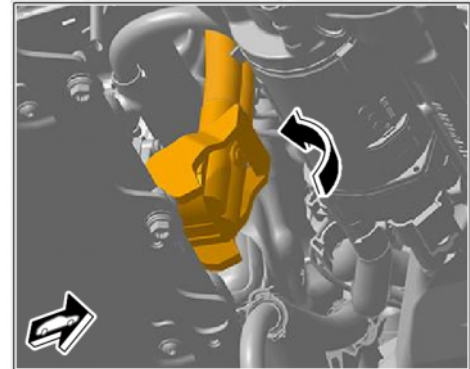

High-voltage line on high-volt battery

23 Clip coolant tubes ⇒ *Securing coolant pipes -1-* into holder ⇒ *Securing coolant pipes -2-*.

24 On vehicles with PDCC, fasten front anti-roll bar. ⇒ *Workshop Manual '407709 Loosening and securing front anti-roll bar (PDCC)'*

25 Install front-axle support (rear section). ⇒ *Workshop Manual '400819 Removing and installing front axle support (rear section)'*

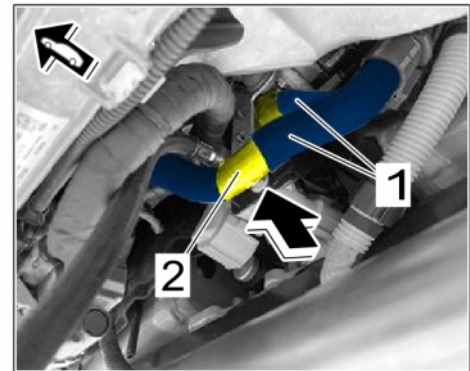

Securing coolant pipes

26 Unscrew screws ⇒ *Adapter plug on high-voltage line -1-* and remove adapter plug ⇒ *Adapter plug on high-voltage line -2-*.

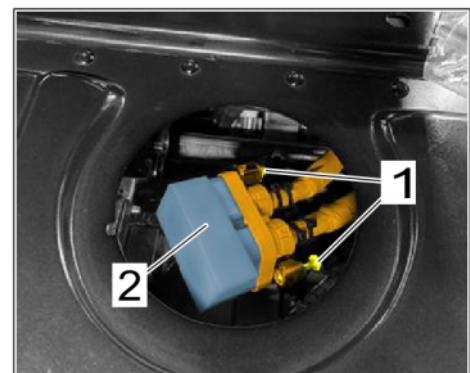

Adapter plug on high-voltage line

- 27 Unscrew screws ⇒ *Adapter plate on high-volt battery -1-* and remove adapter plate ⇒ *Adapter plate on high-volt battery -2-*.

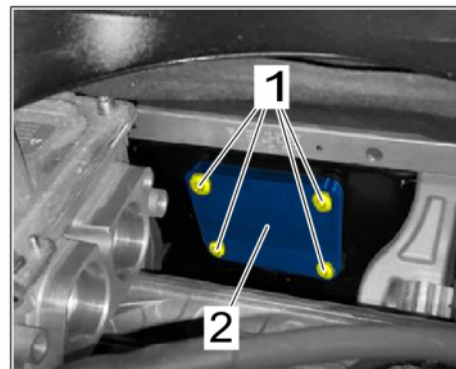

Adapter plate on high-volt battery

- 28 Install **new** pressure valve ⇒ *Pressure valve -2-*.

- 28.1 Clean sealing surface on high-volt battery with isopropanol.
- 28.2 Set pressure valve ⇒ *Pressure valve -2-*.
- 28.3 Screw in **new** screws ⇒ *Pressure valve -1-* and tighten with **tightening torque 8 Nm (5.9 ftlb.)**.

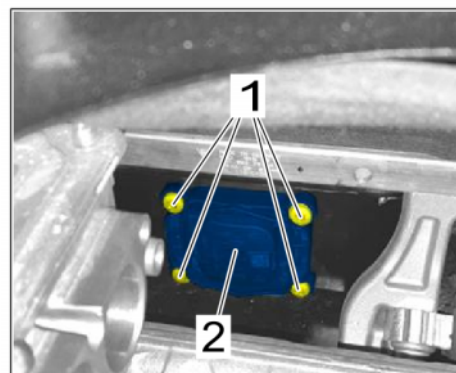

Pressure valve

- 29 Install Styrofoam element ⇒ *Installing Styrofoam element -1-*.

- 29.1 Carefully position Styrofoam element ⇒ *Installing Styrofoam element -1-* from above.
- 29.2 Clip in clips ⇒ *Installing Styrofoam element -2-*.

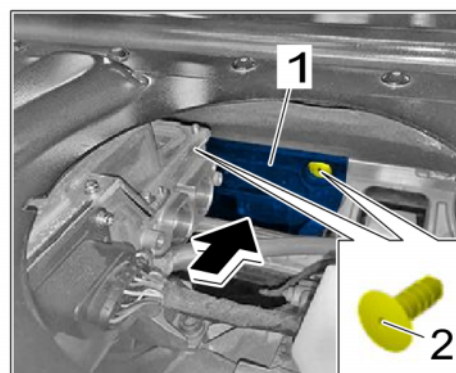

Installing Styrofoam element

- 30 Connect electric plug connection to rear electric machine.
 - 30.1 Connect electric plug connection to rear electric machine.
 - 30.2 Screw in screws ⇒ *High-voltage line for rear electric machine -1-* and tighten with **tightening torque 8 Nm (5.9 ftlb.)**.
- 31 Insert body cover.
- 32 Install insulating mat.
 - 32.1 Insert insulating mat.
 - 32.2 Fasten plastic clips at the corners of the insulating mat.
- 33 Install (center) luggage compartment trim panel (luggage compartment cover).
⇒ *Workshop Manual '70061900 Remove and install (centre) luggage compartment trim panel (luggage compartment cover)'*
- 34 Start the high-voltage system.
⇒ *Workshop Manual '2X00IN Activate/Start high-voltage system'*
- 35 Read out and erase fault memories.
- 36 Enter the campaign in the Warranty and Maintenance logbook.

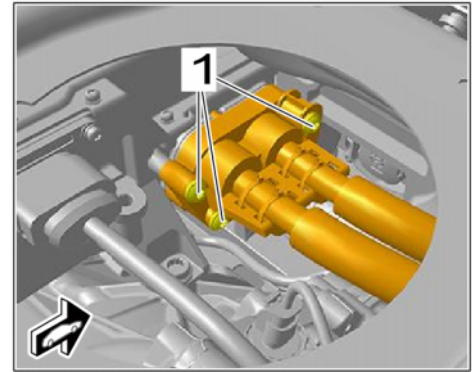

High-voltage line for rear electric machine

Replacing high-volt battery



Information

The high-volt battery needs to be replaced only if both pressure tests have identified a leak on the high-volt battery.

- Work Procedure:
- 1 Save the test report of the repeat test, print and attach to PCSS quality line.
 - 2 Remove test equipment for leak test.

- 3 Remove test plug and adapter plug from the box CAN line connection ⇒ *Test plug and adapter plug-1-* and front E-box high-voltage connection ⇒ *Test plug and adapter plug-2-*.

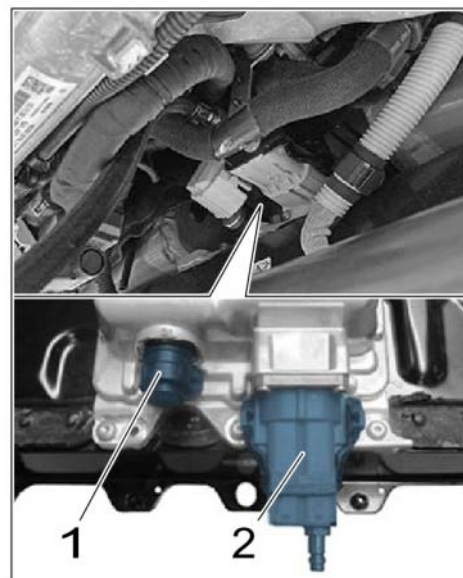

Test plug and adapter plug

- 4 Unscrew screws ⇒ *Adapter plug on high-voltage line-1-* and remove adapter plug ⇒ *Adapter plug on high-voltage line-2-*.

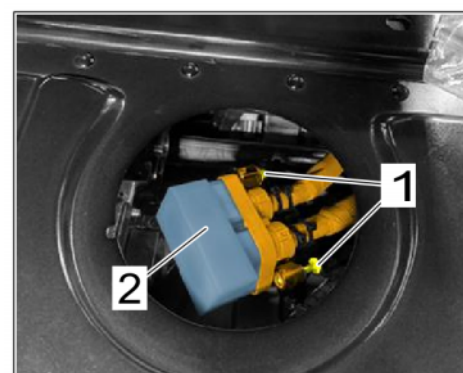

Adapter plug on high-voltage line

- 5 Unscrew screws ⇒ *Adapter plate on high-volt battery-1-* and remove adapter plate ⇒ *Adapter plate on high-volt battery-2-*.

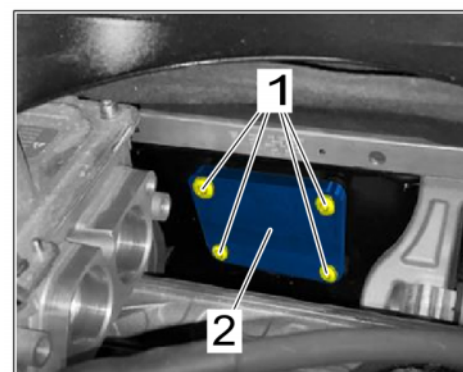

Adapter plate on high-volt battery

- 6 Install **previous** pressure valve ⇒ *Pressure valve -2-*.
 - 6.1 Clean sealing surface on high-volt battery with isopropanol.
 - 6.2 Set pressure valve ⇒ *Pressure valve -2-*.
 - 6.3 Screw in screws ⇒ *Pressure valve -1-* and tighten with **tightening torque 8 Nm (5.9 ftlb.)**.
- 7 Replace high-volt battery.
For instructions, see: ⇒ *Workshop Manual '270855 Replacing high-volt battery'*

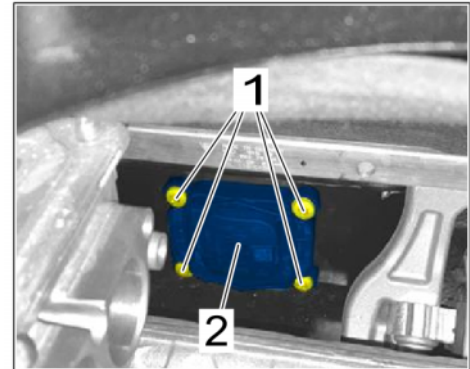

Pressure valve



Information

If the HV battery needs to be replaced, the faulty battery must be disposed of in accordance with PCNA and legal requirements.

NOTE: THESE BATTERIES SHOULD NOT BE RETURNED TO THE PDC.

Porsche Centers should follow processes listed on PPN once ready for disposal - <https://ppn.porsche.com/portal/docs/DOC-488949>

- 8 Enter the campaign in the Warranty and Maintenance logbook.

Warranty processing



Information

The specified labor times were determined specifically for carrying out this campaign and include all necessary preliminary and subsequent rework. The labor times may differ from the labor times published in the Labor Operation List in PCSS.

Scope 1: **Performing leak test on the high-volt battery**

- One leak test performed
- Vehicles without PDCC (M-No. 1P7)

Labor time:

Performing leak test on the high-volt battery Labor time: **383 TU**

Includes: Activating/Starting the high-voltage system
 Remove and install (center) luggage compartment trim panel (luggage compartment cover)
 Classify lithium-ion battery.

Required parts:

V04015007AP	Pressure valve	1 piece
N 10700201	Internal hexagon round-head bolt	4 pieces

⇒ **Damage Number APB2 099 000 1**

Scope 2:

Performing leak test on the high-volt battery

- One leak test performed
- Vehicles with PDCC (M-No. 1P7)

Labor time:

Performing leak test on the high-volt battery Labor time: **405 TU**

Includes: Activating/Starting the high-voltage system
 Remove and install (center) luggage compartment trim panel (luggage compartment cover)
 Classify lithium-ion battery.

Required parts:

V04015007AP	Pressure valve	1 piece
N 10700201	Internal hexagon round-head bolt I	4 pieces
N 91006202	Hexagon-head bolt	4 pieces

⇒ **Damage Number APB2 099 000 1**

Scope 3 - 14: Not applicable for NAR vehicles.

Scope 15: **Replacing high-volt battery**

- Valid for USA/Canada
- Vehicles without PDCC (M-No. 1P7)
- High-volt battery 93 KWh (M-No. J9K)

Labor time:

Replacing high-volt battery

Labor time: **1015 TU**

Includes: Performing leak test on the high-volt battery (installed)
 Activating/Starting the high-voltage system
 Remove and install (center) luggage compartment trim panel (luggage compartment cover)
 Classify lithium-ion battery.

Required parts:

9J1915100CX	High-volt battery	1 piece
9A701053900	EN Warning signs	1 piece
9A701053910	FR warning sign	1 piece

Additional reimbursement:

APB200000001	Disposal costs	1 piece (for warranty invoicing only)
APB200000002	Flat-rate transport fee	1 piece (for warranty invoicing only)

For warranty processing, the **Part No. APB200000001** with the designation "disposal costs" and **Part No. APB200000002** with the designation "flat-rate transport fee" can be invoiced as an **additional part** of the warranty claim. Maximum amount \$ 2,100 (disposal costs) or \$ 1,575 (flat-rate transport fee). Please document a copy of the invoice for this in the warranty claim.

⇒ **Damage Number APB2 099 000 2**

Scope 16: **Replacing high-volt battery**

- Valid for USA/Canada
- Vehicles with PDCC (M-No. 1P7)
- High-volt battery 93 KWh (M-No. J9K)

Labor time:

Replacing high-volt battery Labor time: **1037 TU**

Includes: Performing leak test on the high-volt battery (installed)
 Activating/Starting the high-voltage system
 Remove and install (center) luggage compartment trim panel (luggage compartment cover)
 Classify lithium-ion battery.

Required parts:

9J1915100CX	High-volt battery	1 piece
N 91006202	Hexagon-head bolt	4 pieces
9A701053900	EN Warning signs	1 piece
9A701053910	FR warning sign	1 piece

Additional reimbursement:

APB200000001	Disposal costs	1 piece (for warranty invoicing only)
APB200000002	Flat-rate transport fee	1 piece (for warranty invoicing only)

For warranty processing, the **Part No. APB200000001** with the designation “disposal costs” and **Part No. APB200000002** with the designation “flat-rate transport fee” can be invoiced as an **additional part** of the warranty claim. Maximum amount \$ 2,100 (disposal costs) or \$ 1,575 (flat-rate transport fee). Please document a copy of the invoice for this in the warranty claim.

⇒ **Damage Number APB2 099 000 2**

Scope 17: **Replacing high-volt battery**

- Valid for USA/Canada
- Vehicles without PDCC (M-No. 1P7)
- High-volt battery 79 KWh (M-No. J9I)

Labor time:

Replacing high-volt battery

Labor time: **1015 TU**

Includes: Performing leak test on the high-volt battery (installed)
 Activating/Starting the high-voltage system
 Remove and install (center) luggage compartment trim panel (luggage compartment cover)
 Classify lithium-ion battery.

Required parts:

9J1915099BX	High-volt battery	1 piece
9A701053900	EN Warning signs	1 piece
9A701053910	FR warning sign	1 piece

Additional reimbursement:

APB200000001	Disposal costs	1 piece (for warranty invoicing only)
APB200000002	Flat-rate transport fee	1 piece (for warranty invoicing only)

For warranty processing, the **Part No. APB200000001** with the designation "disposal costs" and **Part No. APB200000002** with the designation "flat-rate transport fee" can be invoiced as an **additional part** of the warranty claim. Maximum amount \$ 2,100 (disposal costs) or \$ 1,575 (flat-rate transport fee). Please document a copy of the invoice for this in the warranty claim.

⇒ **Damage Number APB2 099 000 2**

Scope 18:

Replacing high-volt battery

- Valid for USA/Canada
- Vehicles with PDCC (M-No. 1P7)
- High-volt battery 79 KWh (M-No. J9I)

Labor time:

Replacing high-volt battery

Labor time: **1037 TU**

- Includes:
- Performing leak test on the high-volt battery (installed)
 - Activating/Starting the high-voltage system
 - Remove and install (center) luggage compartment trim panel (luggage compartment cover)
 - Classify lithium-ion battery.

Required parts:

9J1915099BX	High-volt battery	1 piece
N 91006202	Hexagon-head bolt	4 pieces
9A701053900	EN Warning signs	1 piece
9A701053910	FR warning sign	1 piece

Additional reimbursement:

APB200000001	Disposal costs	1 piece (for warranty invoicing only)
APB200000002	Flat-rate transport fee	1 piece (for warranty invoicing only)

For warranty processing, the **Part No. APB200000001** with the designation “disposal costs” and **Part No. APB200000002** with the designation “flat-rate transport fee” can be invoiced as an **additional part** of the warranty claim. Maximum amount \$ 2,100 (disposal costs) or \$ 1,575 (flat-rate transport fee). Please document a copy of the invoice for this in the warranty claim.

⇒ **Damage Number APB2 099 000 2**

Important Notice: Technical Bulletins issued by Porsche Cars North America, Inc. are intended only for use by professional automotive technicians who have attended Porsche service training courses. They are written to inform those technicians of conditions that may occur on some Porsche vehicles, or to provide information that could assist in the proper servicing of a vehicle. Porsche special tools may be necessary in order to perform certain operations identified in these bulletins. Use of tools and procedures other than those Porsche recommends in these bulletins may be detrimental to the safe operation of your vehicle, and may endanger the people working on it. Properly trained Porsche technicians have the equipment, tools, safety instructions, and know-how to do the job properly and safely. Part numbers listed in these bulletins are for reference only. The work procedures updated electronically in the Porsche PIWIS diagnostic and testing device take precedence and, in the event of a discrepancy, the work procedures in the PIWIS Tester are the ones that must be followed.

© Porsche Cars North America, Inc.