



HYUNDAI Technical Service Bulletin

GROUP CAMPAIGN	NUMBER 24-01-003H
DATE JANUARY 2024	MODEL(S) Elantra GT (GD)

SUBJECT: UNDERBODY CORROSION PREVENTATIVE SERVICE
(SERVICE CAMPAIGN 995)

★ IMPORTANT

Dealers must perform this service campaign on all affected vehicles prior to customer retail delivery and whenever an affected vehicle is in the shop for any maintenance or repair.

Access the "Vehicle Information" screen via WEBDCS to identify open Campaigns.

Description: In some areas, a vehicle's underbody may exhibit corrosion due to road salt usage. As a preventative measure, cavity wax coating is applied to the internal surfaces of underbody components, and an undercoating spray is applied to the bottom exterior surfaces of specified underbody components. This bulletin describes the procedure to perform this preventative service on certain Elantra GT (GD) vehicles.



Applicable Vehicles (Certain):

- 2013-17MY Elantra GT (GD) vehicles currently or ever registered in a Salt Belt State produced 05/02/2012 to 01/26/2017.

Salt Belt Areas include:

Connecticut, Delaware, Illinois, Indiana, Iowa, Kentucky, Maine, Maryland, Massachusetts, Michigan, Minnesota, Missouri, New Hampshire, New Jersey, New York, Ohio, Pennsylvania, Rhode Island, Vermont, Virginia, West Virginia, Wisconsin, and the District of Columbia.

Please note all dealers must perform this service campaign if vehicle comes in with an open campaign, even if vehicle is no longer located in the listed states above.

i Information

Allow the vehicle to cool at least four hours before performing the procedures in this TSB. Parking the vehicle at the stall overnight is highly recommended to avoid a need for a cool down period and improve work efficiency.

Circulate To: General Manager, Service Manager, Parts Manager, Warranty Manager, Service Advisors, Technicians, Body Shop Manager, Fleet Repair

Table of Contents

Parts Information:.....3
Recommended Tools and Equipment:.....4
Warranty Information:5
Service Procedures:.....5
 Wax Gun Preparation:.....5
 Remove Debris:.....7
 Vehicle Preparation:11
 Applying Cavity Wax:.....12
 Applying Undercoating:14

*** IMPORTANT**

There are circumstances under which vehicles that are not currently registered or have never been registered in a “salt belt” state may be eligible for this service campaign. These circumstances include:





- Vehicles that were relocated into a “salt belt” area and/or
- Vehicles registered in a “non-salt belt” state and driven in a “salt belt” area

If it is determined that an owner of a vehicle within the affected VIN production date range relocates or has operated their vehicle in a “salt belt” area, the dealer should perform this procedure at no cost to the customer. **The dealer must submit a Prior Approval request before starting repairs.**

Parts Information:



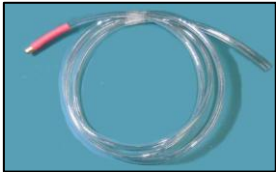





! DANGER

- This procedure must be performed in a well-ventilated area.
- Must wear safety goggles, face protection, and gloves. Rinse eyes with water or skin with soap and water. Do not inhale spray. Seek medical attention if needed.
- Flammable & pressurized. Do not spray near flames, sparks, or heated areas. Do not pierce can.

Part Name	Image / Part Number	Remark
Cavity Wax		Use about half a can per vehicle.
	00232-19034	
Undercoat Spray		Use about 1 can per vehicle.
	00232-19035	
Wax Spray Gun		Set air pressure to 70 psi. <i>If wax output is slow</i> , prime the gun by blocking the nozzle with a rag, and spraying the gun until the flow of wax increases.
	00232-19036	
"Inside" Nozzle		This is a newly developed nozzle that has an improved wax application spray pattern.  The pink tubing is to signal the user to stop spraying when pulling the nozzle out. <u>This nozzle must be used for this service procedure.</u>
	09624-2H101-QQH	

"Outside" Nozzle		This nozzle is supplied with the wax gun.
------------------	---	---

Required Supplies:

Tool Name	Image	Remark
Air Nozzle		
Safety Goggles		
Face Mask		
Gloves		
Rubber/Plastic Mallet		
Wire Brush		
Plastic bags		Bags large enough to cover the tires and wheels.
Tape		

*Above are standard shop supply.

Warranty Information:

Model	Op Code	Description	Op Time	Causal Part	Nature	Cause
Elantra GT (GD)	30D063R0	UNDER BODY RUST INSPECTION AND PREVENTIVE SERVICE	0.8 M/H	62400-3X000	A12	ZZ6

NOTE 1: Submit claim on Claim Entry Screen as “Campaign” type.

NOTE 2: Each labor operation will reimburse 1 can of undercoat spray and cavity wax.

NOTE 3: If a part that is not covered by this campaign is found in need of replacement while performing the service campaign and the affected part is still under warranty, submit a separate claim using the same repair order. If the affected part is out of warranty, submit a Prior Approval request for goodwill consideration prior to the repair.

NOTE 4: This TSB includes Repair validation photos. Op times include VIN, Mileage and Repair validation photos as outlined in the Digital Documentation Policy.

Service Procedures:

STUI



This TSB includes Repair validation photos. Refer to the latest Warranty Digital Documentation Policy for requirements.

Wax Gun Preparation:

! DANGER

- This procedure must be performed in a well-ventilated area.
- Must wear safety goggles, face protection, and gloves. Rinse eyes with water or skin with soap and water. Do not inhale spray. Seek medical attention if needed.
- Flammable & pressurized. Do not spray near flames, sparks, or heated areas. Do not pierce can.

1. Unscrew the nut to remove the compression fitting from the nozzle assembly that originally comes with the wax gun.



2. Attach the compression fitting to the tubing on the new nozzle assembly.

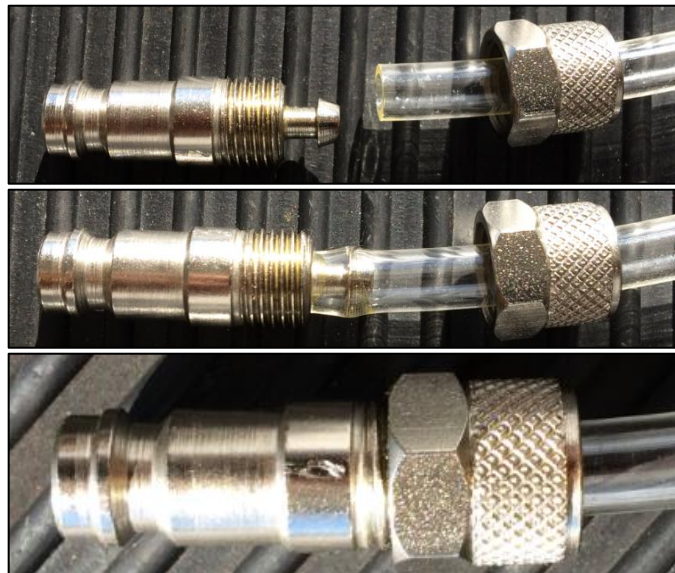

3. Fill wax gun reservoir with cavity wax.

Prime the wax gun by spraying the wax into a trash bag (or similar) until a light mist is visibly coming out of the nozzle.

i Information

Set air supply pressure to 70 psi.

Prime the wax spray gun to increase the flow when the mist is no longer visible.

To optimize the priming process, cover the nozzle with a rag and spray until the flow has increased.



Remove Debris:

! WARNING

Must wear safety goggles and a face mask during this procedure to protect eyes and prevent debris from being inhaled.

1. Lift the vehicle on a hoist.

Apply a plastic vinyl sheet on the floor.

If equipped, remove plastic undercovers to gain access to the front sub-frame, brake, and fuel tubes.



2. Lightly tap the vehicle underbody components with a rubber or plastic mallet to loosen and remove debris.



Front Underbody

- Front sub-frame (A)
- Front lower control arms (B)

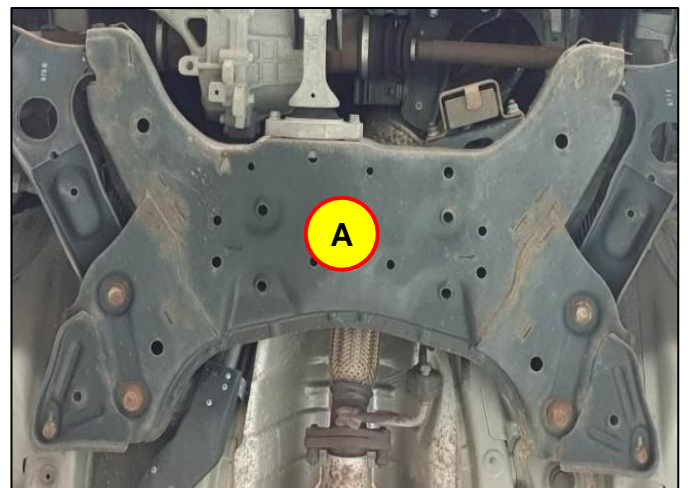

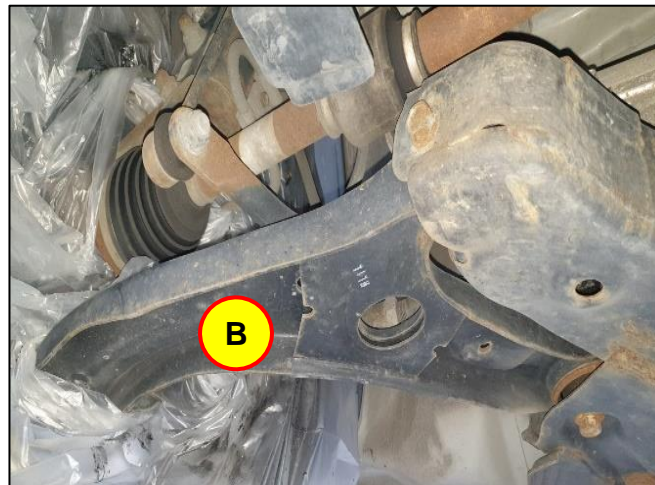

Rear Underbody

- Coupled torsion beam axle (CTBA) (C)

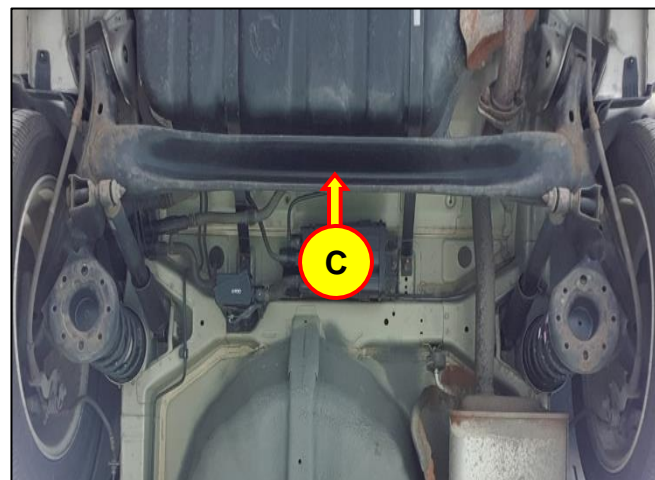

3. Use a wire brush to remove debris from:

- Front sub-frame
- Front lower arms
- CTBA



4. Clean the brake banjo bolt surfaces at all four calipers and brake tube fasteners using a wire brush.

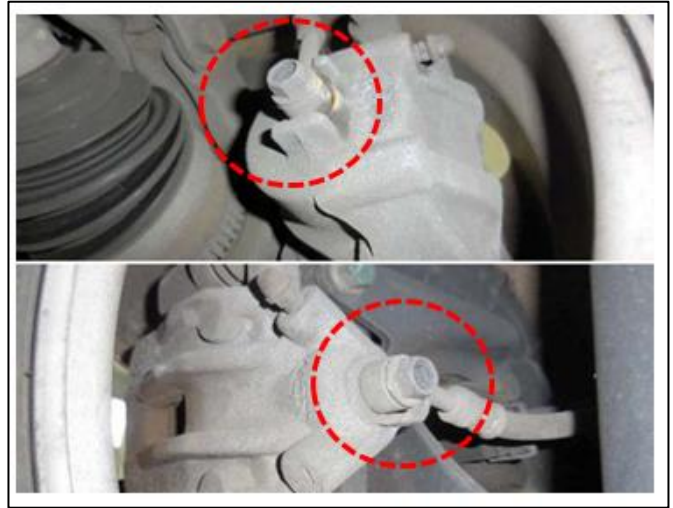
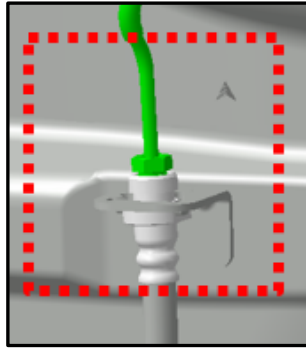

5. Remove the remaining debris by inserting an air nozzle into the interior cavities of the sub-frames and control arms. Then blow air in multiple directions.

Blow air over the exterior surfaces of components as well.

Use the marked areas as a guideline to insert the nozzle. Additional access might be possible to remove more debris.

Front Underbody

- Front sub-frame
- Front lower control arms

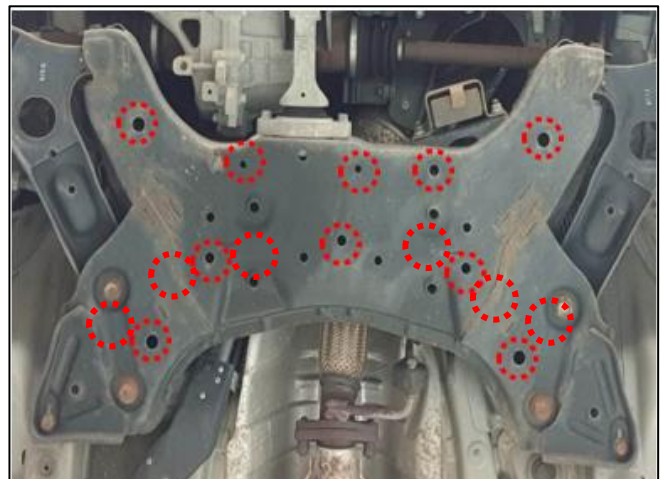

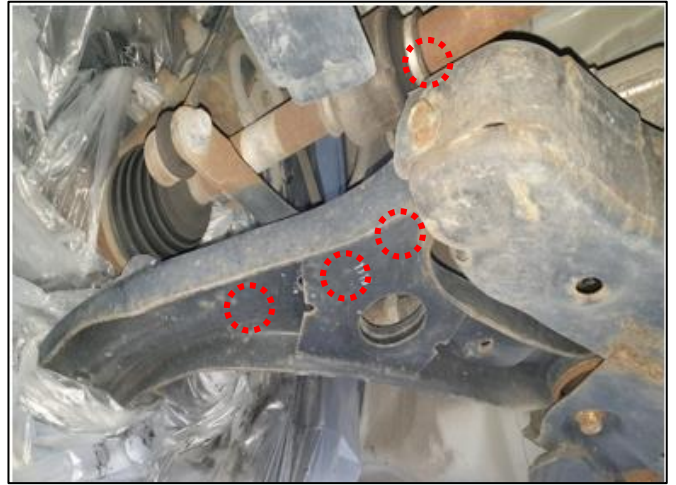

Rear Underbody
• CTBA

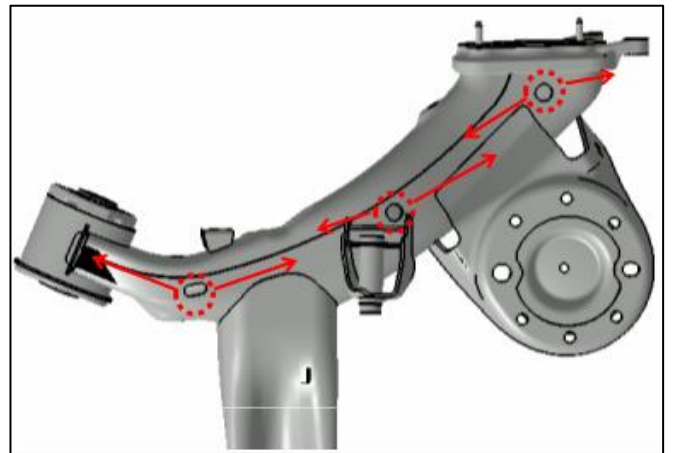

Vehicle Preparation:

1. Wrap the brakes with plastic bags to protect them from overspray. Use tape to secure the plastic in place. Leave the banjo fitting area exposed as shown.

! CAUTION

- The brakes must be sufficiently cooled before it is wrapped.
- May cause burns and melt the plastic.



2. Wrap large plastic bags around the tires and wheels to protect them from overspray. Use tape to secure the plastic in place.



3. Wrap the exhaust areas adjacent to the front sub-frame and rear CTBA with plastic bags to protect them from overspray. Use tape to secure the plastic in place.

! CAUTION

- The exhaust must be sufficiently cooled before it is wrapped.
- May cause burns and melt the plastic.

Applying Cavity Wax:

! DANGER

- This procedure must be performed in a well-ventilated area.
- Must wear safety goggles, face protection, and gloves. Rinse eyes with water or skin with soap and water. Do not inhale spray. Seek medical attention if needed.
- Flammable & pressurized. Do not spray near flames, sparks, or heated areas. Do not pierce can.

Apply the cavity wax at each of the locations noted in the following steps.

Generally for coating interior surfaces, insert the “inside” nozzle as deeply as possible at each point of entry. Spray the cavity wax while simultaneously rotating the nozzle, and slowly pulling the nozzle out. Continue this rotating/pulling motion until the pink tubing is seen coming out of the hole. The pink tubing indicates there is about 50mm of tubing left until the end of the nozzle. Stop spraying when the pink tubing is seen.

Generally for coating exterior surfaces, use the “outside” nozzle, provided with the wax gun. Use this nozzle if the inside nozzle is too large to access the internal cavity of the components.

1. Use the marked areas as a guideline to insert the cavity wax nozzle. Additional access into the internal cavity of the components might be possible.

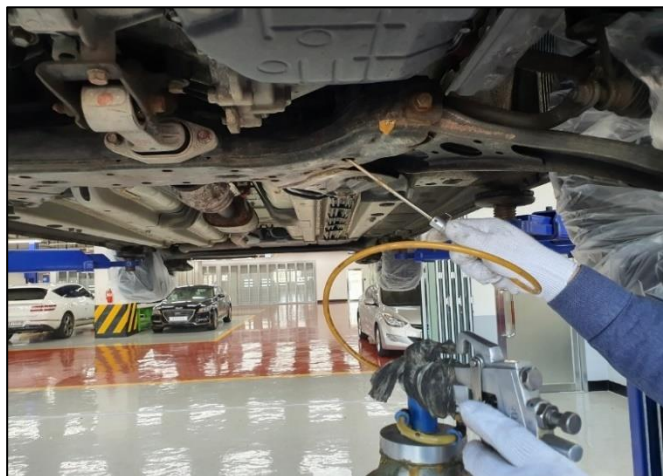

Front Underbody

- Front sub-frame

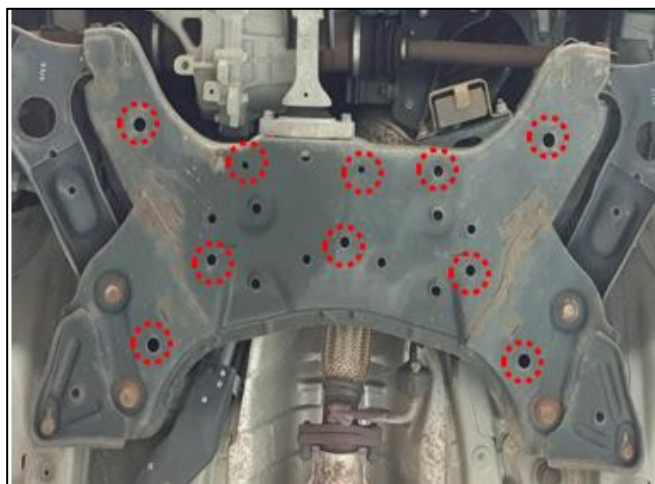

Rear Underbody

- CTBA

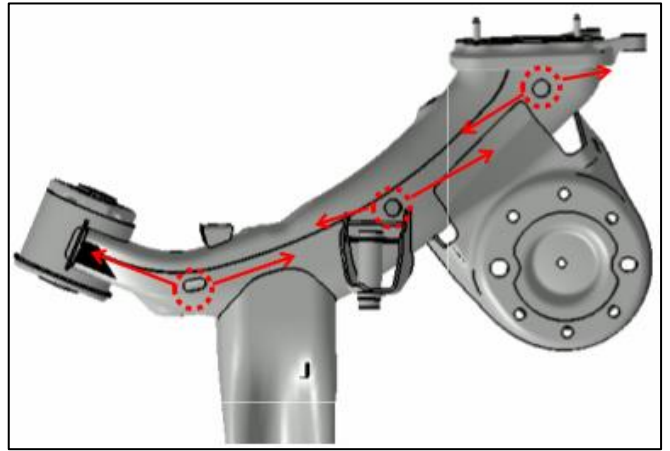

Applying Undercoating:

! DANGER

- This procedure must be performed in a well-ventilated area.
- Must wear safety goggles, face protection, and gloves. Rinse eyes with water or skin with soap and water. Do not inhale spray. Seek medical attention if needed.
- Flammable & pressurized. Do not spray near flames, sparks, or heated areas. Do not pierce can.

Spray the black undercoating on all exterior surfaces of the front sub-frame, front lower arms, rear CTBA, front and rear brake caliper banjos, brake tube brackets, and fuel & brake tubes. Refer to the following images.

1.

Front sub-frame

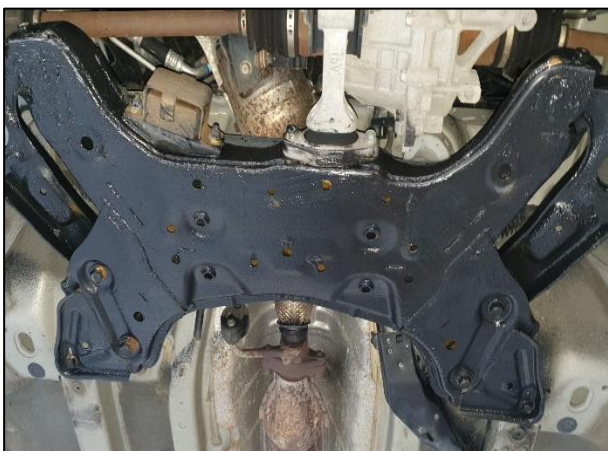

Front lower arms



Rear CTBA



Banjo and brackets at each wheel position

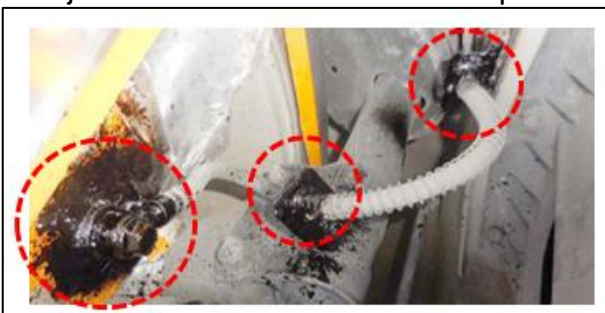

2. Additional brake and fuel tube brackets and connectors:

- Brake 2-way connector (A)
- Brake tube mounts (B)
- Rear brake and fuel tubes within the area marked in red (C)

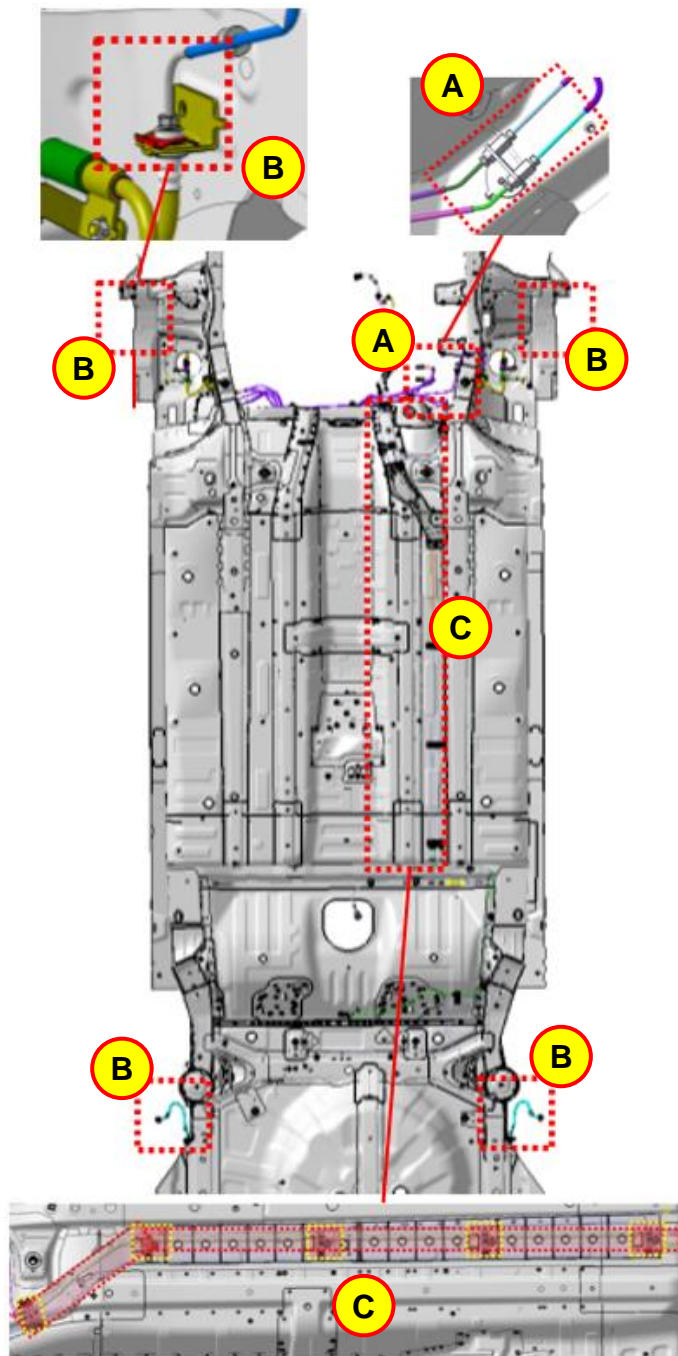

3. Remove all the plastic bags.

4.

STUI



Using STUI, take clear photos of the following components after the undercoating is applied with the last 6 digits of the VIN and the date of repair on a piece of paper. See examples shown to the right.

1. Front sub-frame
2. Rear CTBA
3. Left front lower control arm
4. Right front lower control arm

Upload all photos to STUI.

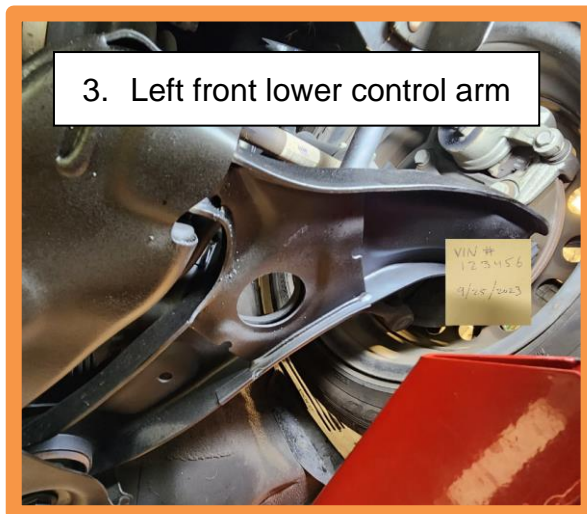
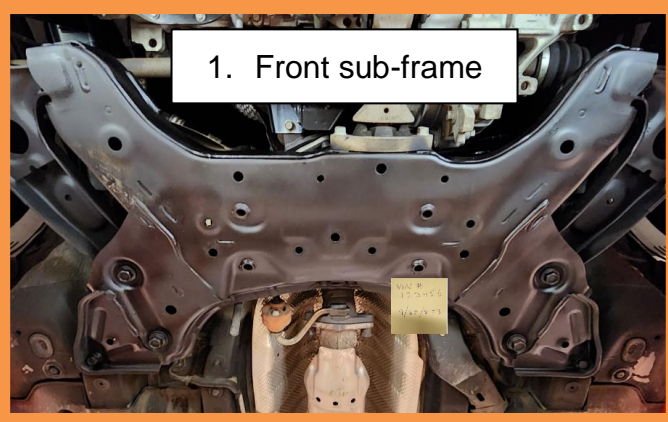

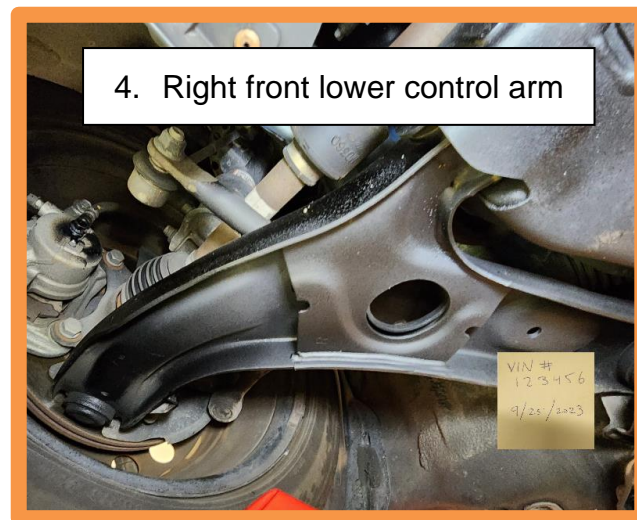

5. Reinstall the parts in the reverse order of removal.
6. The procedure is now complete.