

January 31, 2024

Version 1

Popping/Crackling from the Speakers; Display Blank

AFFECTED VEHICLES

Year	Model	Trim Level	VIN Range
2022–24	RDX	ALL	ALL

SYMPTOM

There is a popping or crackling from the speakers, a blank display, or no sound from the audio system. You may also see a **Network Loss** message.

POSSIBLE CAUSE

There is a loose connection in the MOST bus network.

CORRECTIVE ACTION

Install the FAKRA splice repair service cables and splice boxes.

PARTS INFORMATION

Part Name	Part Number	Quantity
Splice boxes	39817-THR-305	2 Splice boxes (4 Halves)
FAKRA splice repair service cable (Blue)	39165-THR-AC0	2

TOOL INFORMATION

Tool Name	Tool Number	Quantity
Straight FAKRA Puller	07AAC-THRA200	1

NOTE: For more information on using the FAKRA tools see the job aid: *Using the MOST Connector Tools*.

CLIENT INFORMATION: The information in this bulletin is intended for use only by skilled technicians who have the proper tools, equipment, and training to correctly and safely maintain your vehicle. These procedures should not be attempted by “do-it-yourselfers,” and you should not assume this bulletin applies to your vehicle, or that your vehicle has the condition described. To determine whether this information applies, contact an authorized Acura automobile dealer.

WARRANTY CLAIM INFORMATION

The normal warranty applies.

Operation Number	Description	Flat Rate Time	Defect Code	Symptom Code	Template ID	Failed Part Number
0101T5	Access the center console and passenger kick panel in-line connectors, then replace the affected FAKRA splice repair service cables, and splice boxes.	1.1 hr	03214	03217	B23038A	39540-TJB-A01

Skill Level: Repair Technician

FAKRA CONNECTOR HOUSING DISASSEMBLY/FAKRA SPLICE REPAIR SERVICE CABLE ASSEMBLY PROCEDURE

1. Follow the below steps to better understand the cable and splice box installation instructions.
2. The connectors will either be the original FAKRA housing or the WPC FAKRA service housing.

NOTE:

- There may be multiple components that require the affected FAKRA connectors to be removed.
- Use the straight FAKRA puller to remove the connector from a component.

ORIGINAL FAKRA HOUSING REMOVAL PROCEDURE

1. Use a small screwdriver, remove the secondary lock, then release the tab as shown.

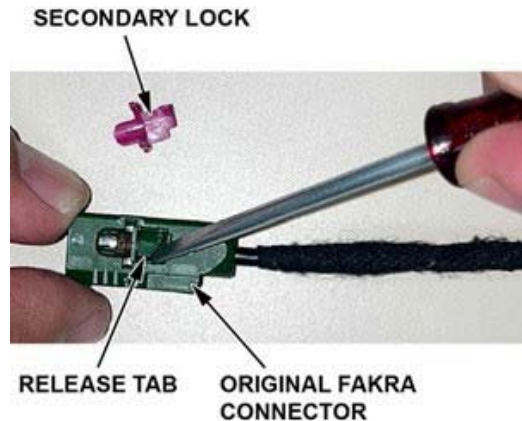

2. Pull to remove the housing from the vehicle harness. Then, **discard** the housing and lock.

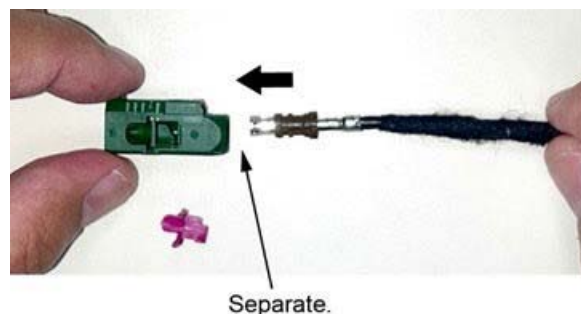

WPC FAKRA SERVICE HOUSING REMOVAL PROCEDURE

1. Release the two locking tabs on the WPC FAKRA service housing and remove the housing from the terminal.

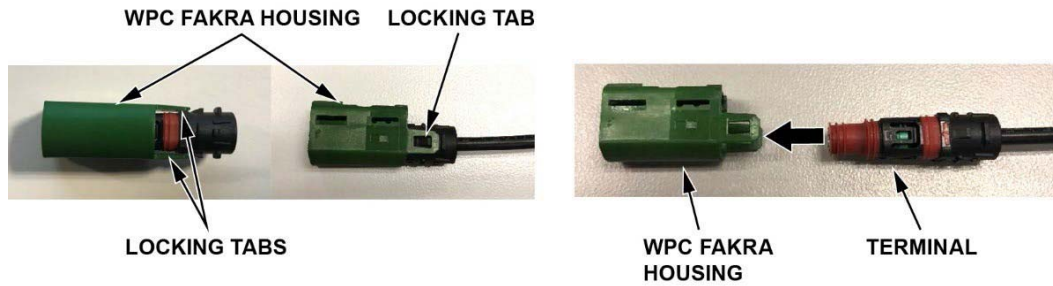

2. Release the lock tab and remove the terminal from the vehicle harness.

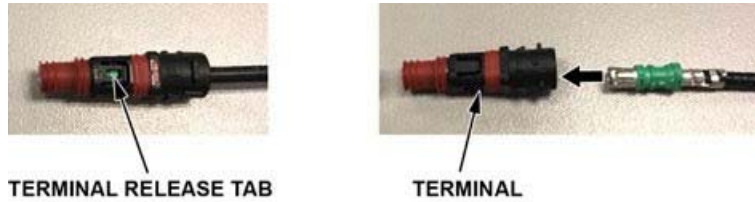

FAKRA SPLICE REPAIR SERVICE CABLE ASSEMBLY

1. Install the appropriate FAKRA splice repair service cables and splice boxes as shown in the steps that follow:

NOTE:

- The splice box arrow must always point in the direction of either the red flag label or red sleeve on the FAKRA splice repair service cable.
- If the splice box is installed **incorrectly**, the repair will fail; MOST ring failure conditions will still occur.
- Some vehicles may not use the 90° FAKRA splice repair service cables.

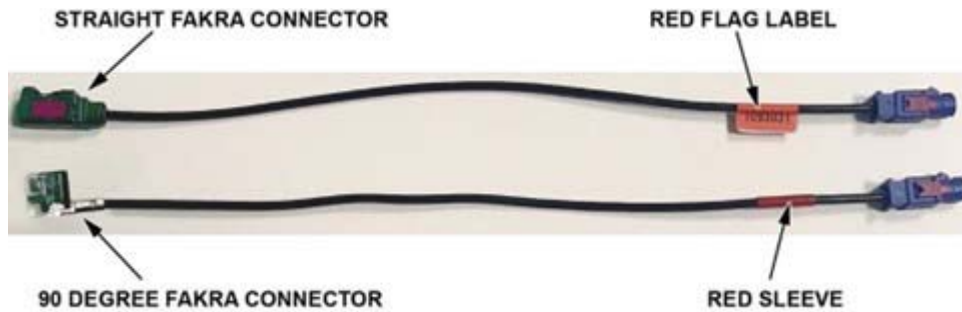

2. Use a small screwdriver to remove the secondary lock and then, release the tab.

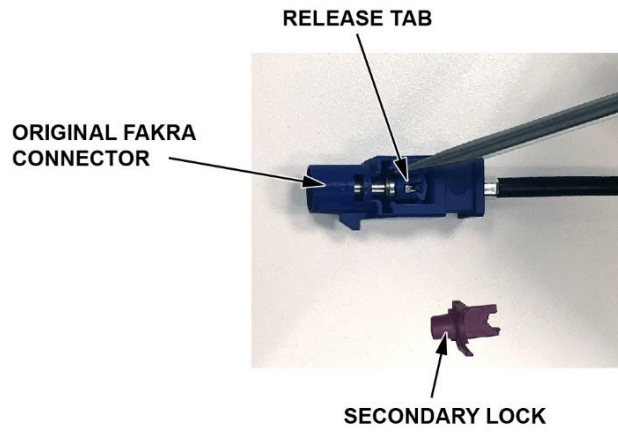

3. Pull to remove the housing from the cable and then discard the housing and secondary lock tab from the FAKRA splice repair service cable.

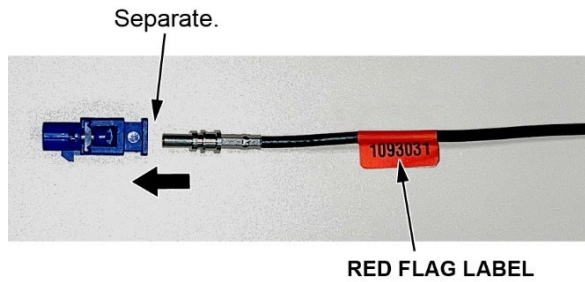

4. Connect the appropriate color FAKRA splice repair service cable to the vehicle harness.

NOTE:

- Make sure the FAKRA service cable is inserted straight into the vehicle harness terminal to avoid damage at the cable connection point.
- Always disassemble the connectors one at a time to avoid swapping the green and red wires.

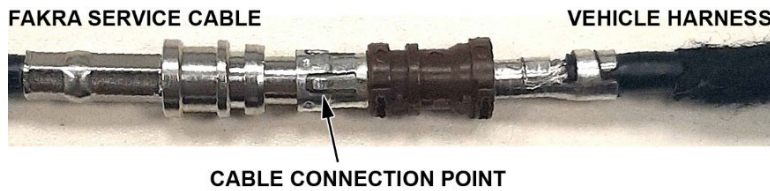

5. Attach the splice box halves to the cable connection.

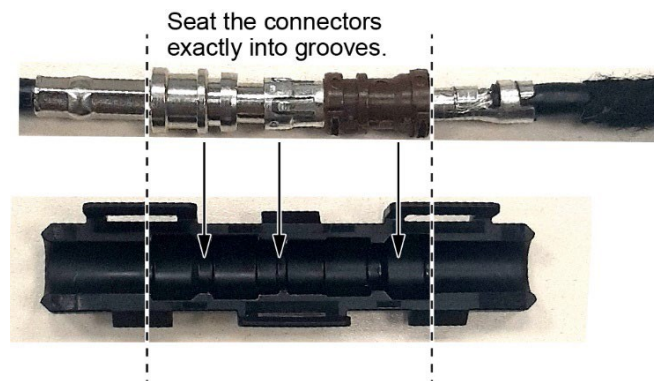

6. When mating the two splice box halves, **make sure** that all **6 lock tabs** are fully engaged. You may hear a click when installing the two halves.

NOTE:

- **The splice box arrow must always point in the direction of the red flag label or red sleeve on the FAKRA splice repair service cable.**
- The splice box is a **one-time** use part; Never reuse the splice box after it has been installed.
- If any of the lock tabs break during installation, the splice box half(s) must be replaced.
- If the splice box is installed **incorrectly**, the repair **will fail**; MOST Ring failure conditions will still occur.

CORRECT ✓

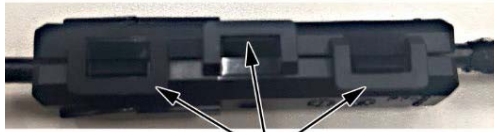

All 6 clips connected.

INCORRECT ✗

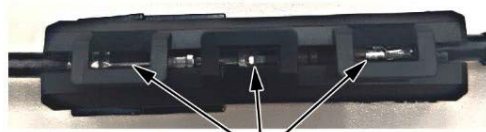

Exposed slice visible.

7. Make sure the arrow on the splice box **faces** towards the red flag label or red sleeve.

NOTE: Do not spin the splice box or the cables as this can cause damage to the connection point.

CORRECT ✓

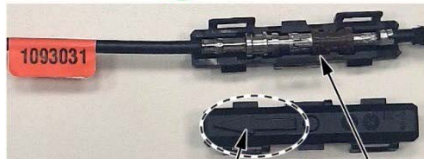

Arrow facing toward red flag label.

Fully seated in splice box.

INCORRECT ✗



- Once the FAKRA splice repair service cables and splice boxes have been attached to the cable connection, tape the splice boxes and FAKRA service cables to the appropriate component harness.

NOTE: Reference below for a correct example of the cable connection routing.

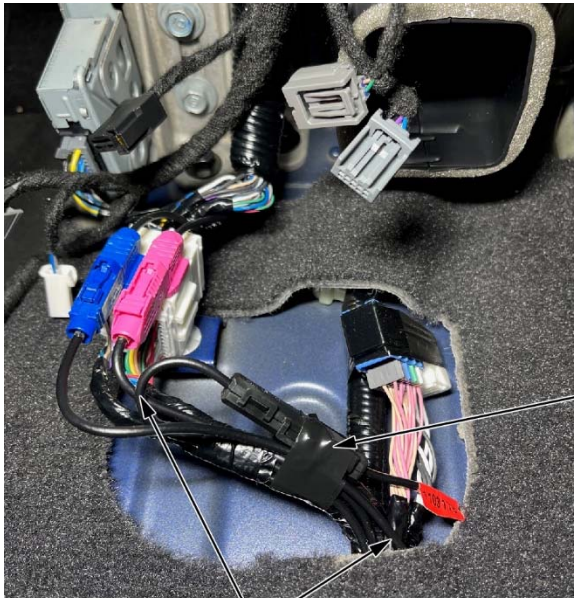

Attach the FAKRA service cable and splice box to the appropriate component harness with tape to prevent any rattles.

Keep smooth curves with a radius bend greater than 25 mm.

CORRECT ✓



Keep smooth curves with a radius bend greater than 25 mm.



INCORRECT ✗



NOTE: Make sure the FAKRA splice repair service cables are not bent at connector(s), as shown below.

CORRECT ✓

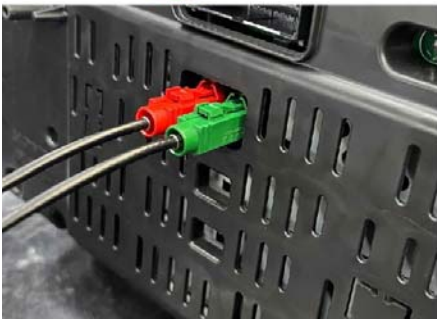

INCORRECT ✗

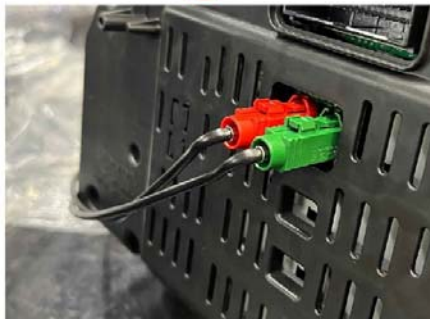

REPAIR PROCEDURE

TRIM REMOVAL PROCEDURE

1. Remove the dash side panel and air vent.

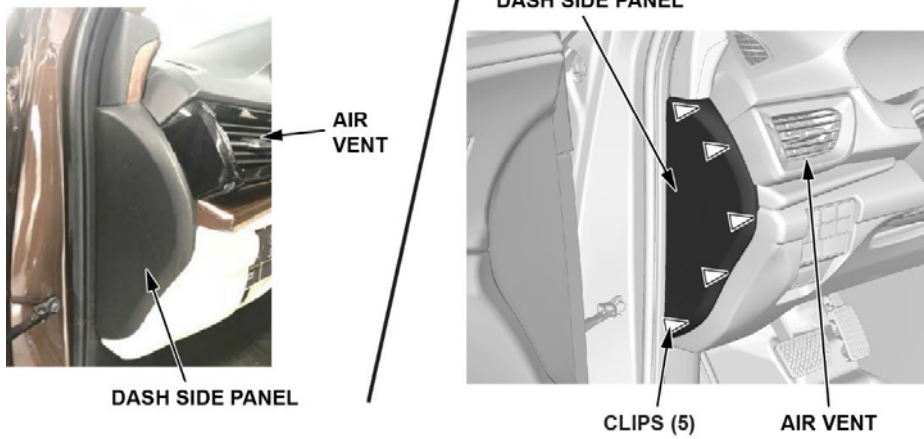

2. Remove the two screws.

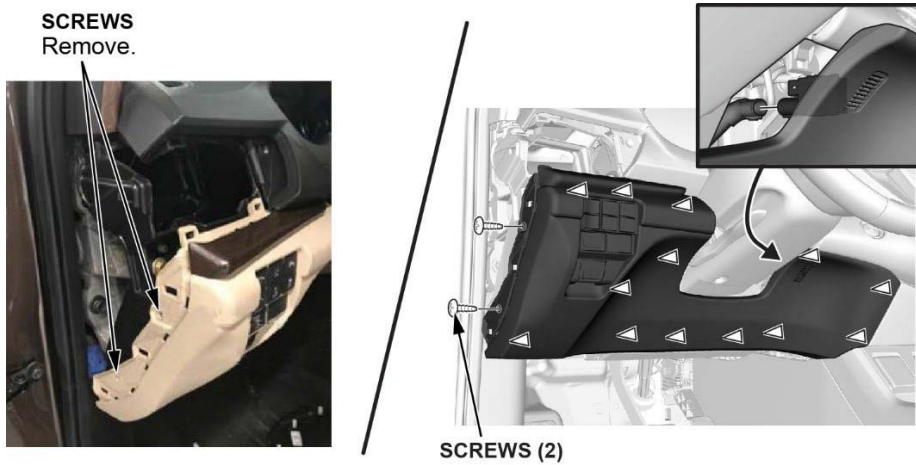

3. Remove the lower trim and disconnect the switch connectors and in-car temperature sensor.

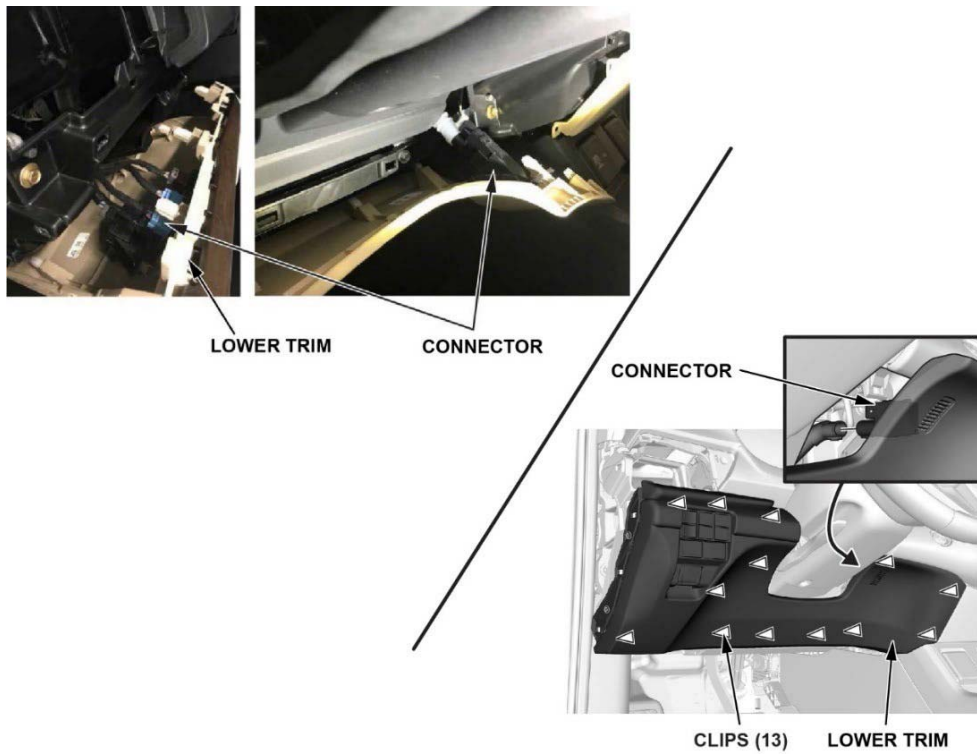

4. Remove driver's side wrapped trim.

DRIVER'S SIDE

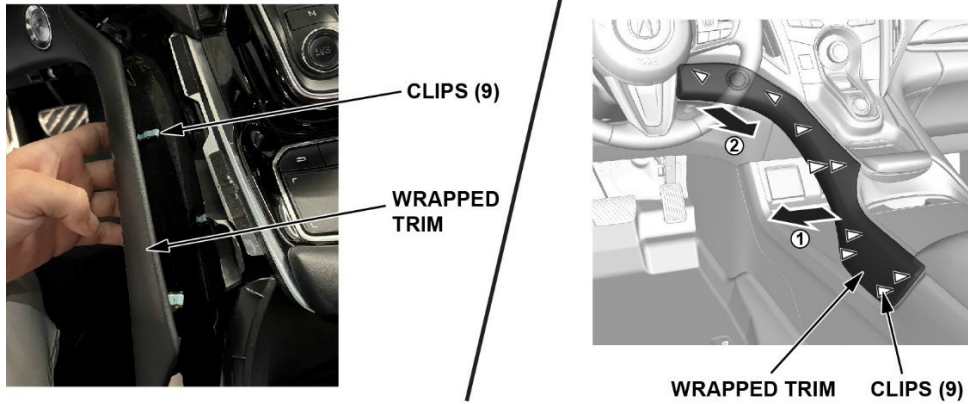

5. Remove the driver side center console panel.

DRIVER'S SIDE

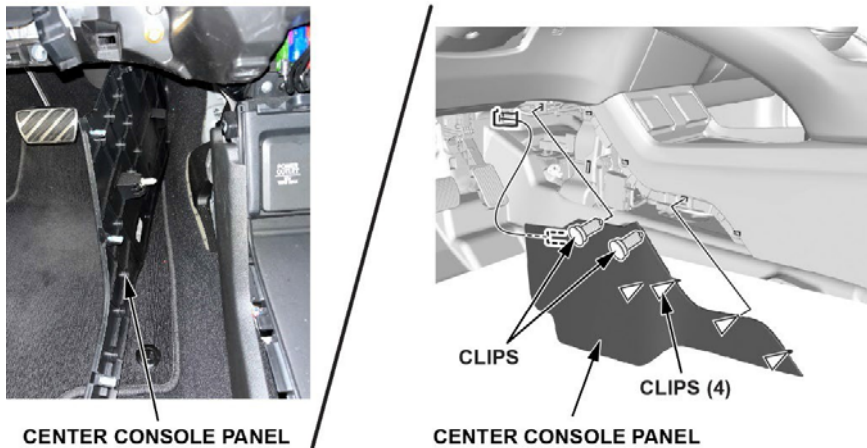

6. Remove the lower center cover to expose the infotainment control unit.



LOWER CENTER COVER
(infotainment control unit located behind)

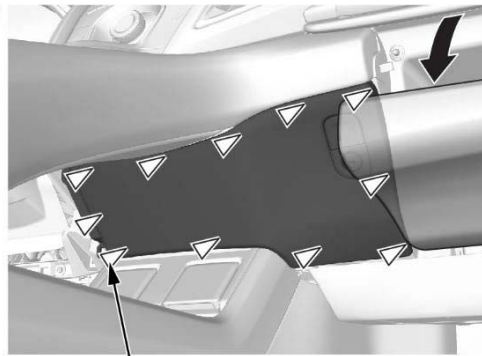

CLIPS (11)

7. Remove the passenger kick panel.

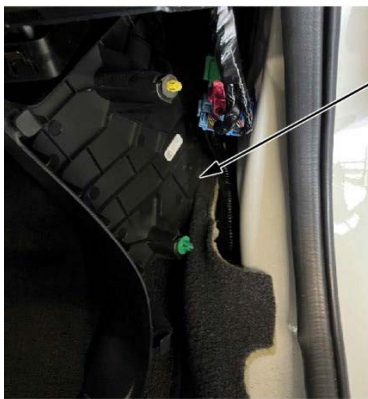

KICK PANEL

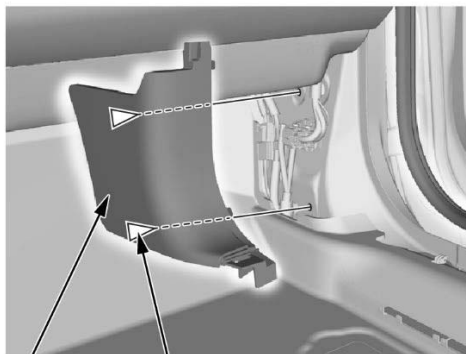

KICK PANEL **CLIPS (2)**

8. Remove the passenger side center console cover.

PASSENGER'S SIDE



CENTER CONSOLE COVER

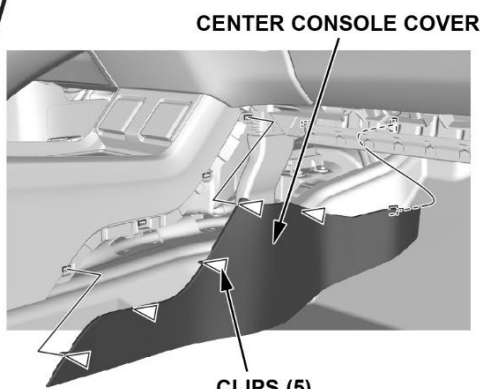

CENTER CONSOLE COVER

CLIPS (5)

9. Remove the passenger side wrapped trim.
 NOTE: Lower the glove box for removal of trim.

PASSENGER'S SIDE



PASSENGER WRAPPED TRIM

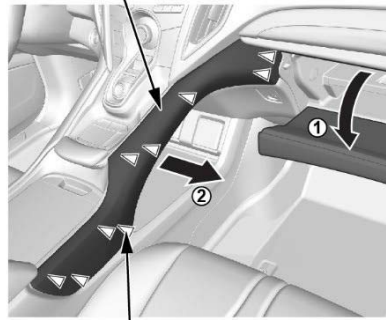

CLIPS (9)

10. Remove the center console rear panel.

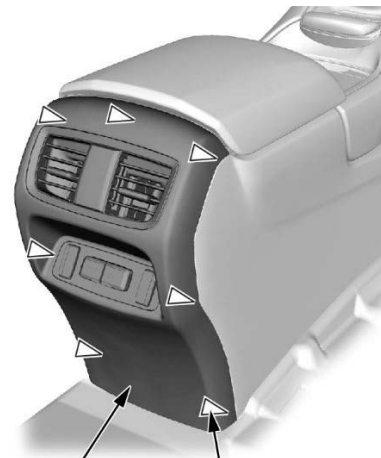

**CENTER CONSOLE
REAR PANEL**

CLIPS (7)

11. Remove the center console.

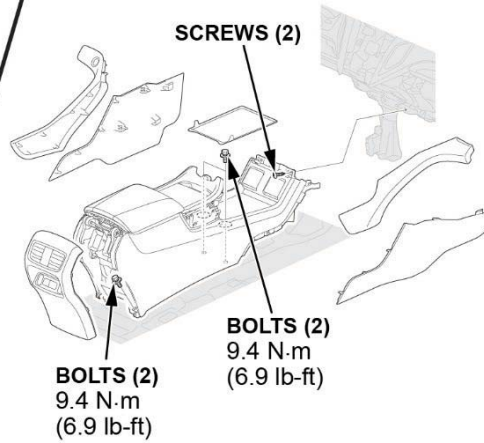

**BOLTS (2)
9.4 N·m
(6.9 lb-ft)**

**BOLTS (2)
9.4 N·m
(6.9 lb-ft)**

CENTER CONSOLE IN-LINE CONNECTOR REPAIR PROCEDURE

1. Disconnect the blue FAKRA connector at the center console.



2. Install the matching color FAKRA splice repair service cable and splice box.

NOTE:

- See the above section **FAKRA Connector Housing Disassembly/FAKRA Splice Repair Service Cable Assembly Procedure** for detailed instructions.
- **The splice box arrow must always point in the direction of the red flag label or red sleeve on the FAKRA splice repair service cable.**
- The splice box is a **one-time** use part; never reuse the splice box after it has been installed.
- If any of the lock tabs break during installation, the splice box half(s) must be replaced.
- If the splice box is installed **incorrectly**, the repair **will fail**; MOST Ring failure conditions will still occur.

3. Tape the FAKRA splice repair cable and splice box to the in-line harness.

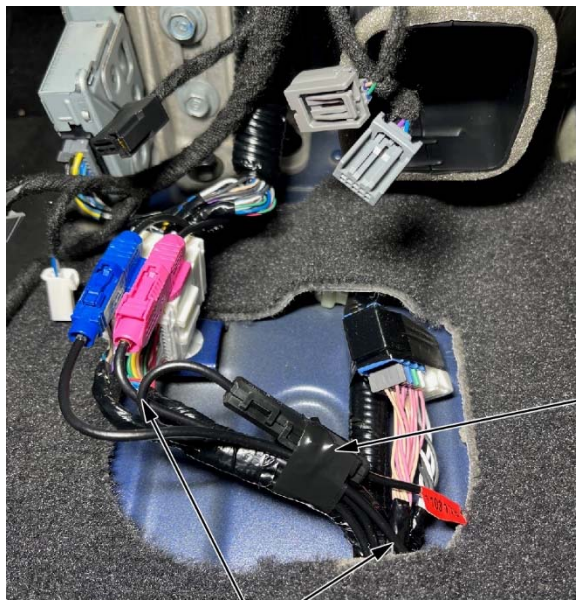

Attach the FAKRA service cable and splice box to the appropriate component harness with tape to prevent any rattles.

Keep smooth curves with a radius bend greater than 25 mm.

4. Reconnect the blue in-line FAKRA connector.

PASSENGER KICK PANEL IN-LINE CONNECTOR REPAIR PROCEDURE

1. Disconnect the blue FAKRA connector at the passenger side kick panel.

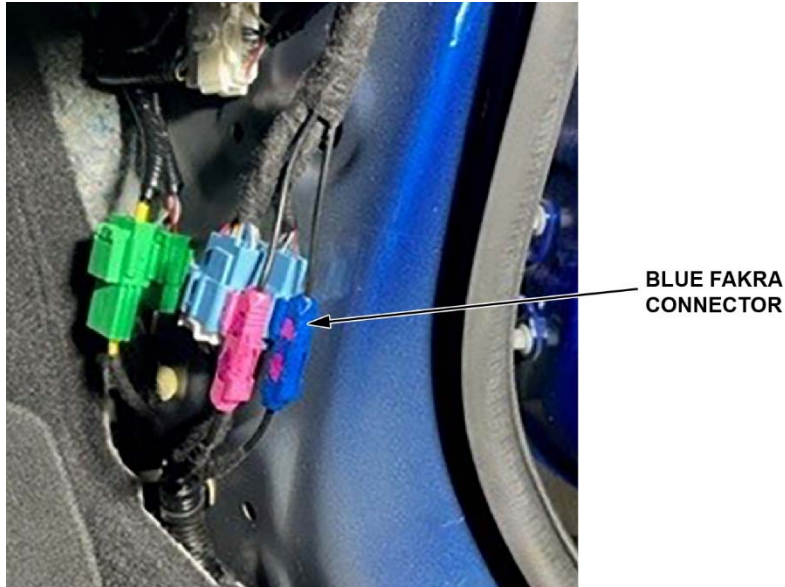

2. Install the matching color FAKRA splice repair service cable and splice box.

NOTE:

- See the above section **FAKRA Connector Housing Disassembly/FAKRA Splice Repair Service Cable Assembly Procedure** for detailed instructions.
- **The splice box arrow must always point in the direction of the red flag label or red sleeve on the FAKRA splice repair service cable.**
- The splice box is a **one-time** use part; never reuse the splice box after it has been installed.
- If any of the lock tabs break during installation, the splice box half(s) must be replaced.
- If the splice box is installed **incorrectly**, the repair **will fail**; MOST Ring failure conditions will still occur.

3. Tape the FAKRA splice repair cable and splice box to the in-line harness.



Keep smooth curves with a radius bend greater than 25 mm.

Attach the FAKRA service cable and splice box to the appropriate component harness with tape to prevent any rattles.

4. Reconnect the blue in-line FAKRA connector.

REPAIR VERIFICATION PROCEDURE

1. Install all of the removed parts in the reverse order of removal.

NOTE:

- When reinstalling components, make sure the harness is routed correctly. A **misrouted harness** can put pressure on the wires and connectors, causing connection issues.
 - **Do not pull** on the units or MOST cables while the FAKRA connectors are connected to help prevent communication issues.
2. Start the vehicle and verify the gauge control module and the infotainment control unit operates normally, then push the power button OFF. Open and close the driver's door and restart the vehicle to reverify the gauge control module and the infotainment control unit operates normally. If all systems operate normally, repair is complete.
 3. If components do not operate as intended, reinspect FAKRA splice repair service cables, splice box connections and routing. Make sure the splice box arrow is pointing to the red flag label or red sleeve on the FAKRA splice box service cable.

NOTE: If all FAKRA splice repair service cables, splice box connections, and routing are correct, follow normal troubleshooting procedures per System Information Search on iN.