

## Frame Or Cab Lean

Published 17 January 2024

### Valid For

Mack models AN, GR,PI,TE,GU,MMD - Model year 2016 to current.

Suspension causes must be ruled out first. There must be a sound base to find any other cause or you will be "chasing ghosts". Determine all suspension parts are correct for the truck and axles, especially the axle seats. Pairs of parts, i.e. springs, etc... are the same, side to side. on the same axle, i.e. front drive/rear drive.

Some reports are showing the cause has been frame lean or "ladder torquing" of frame structures during assembly. Investigation is ongoing and gathering of good information is imperative.

Care must be taken when measuring of frame heights against shop floors due to possible floor irregularities.

### Minimum measurement locations

	Location	Measurement	
		Right	Left
1.	Front of Frame		
2.	Rear of Frame		
3.	Back of Cab		
4.	Front of Tandems		
5.	Rear of Tandems or Rear of Frame		

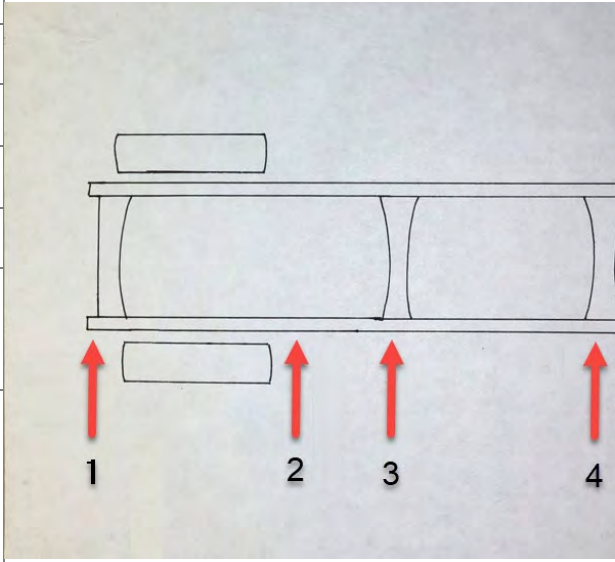

Click [HERE](#) for a printable worksheet.

Use a 4 ft level across the upper frame flanges and measure from the underside to the floor.

This eliminates issues in the flange bends.

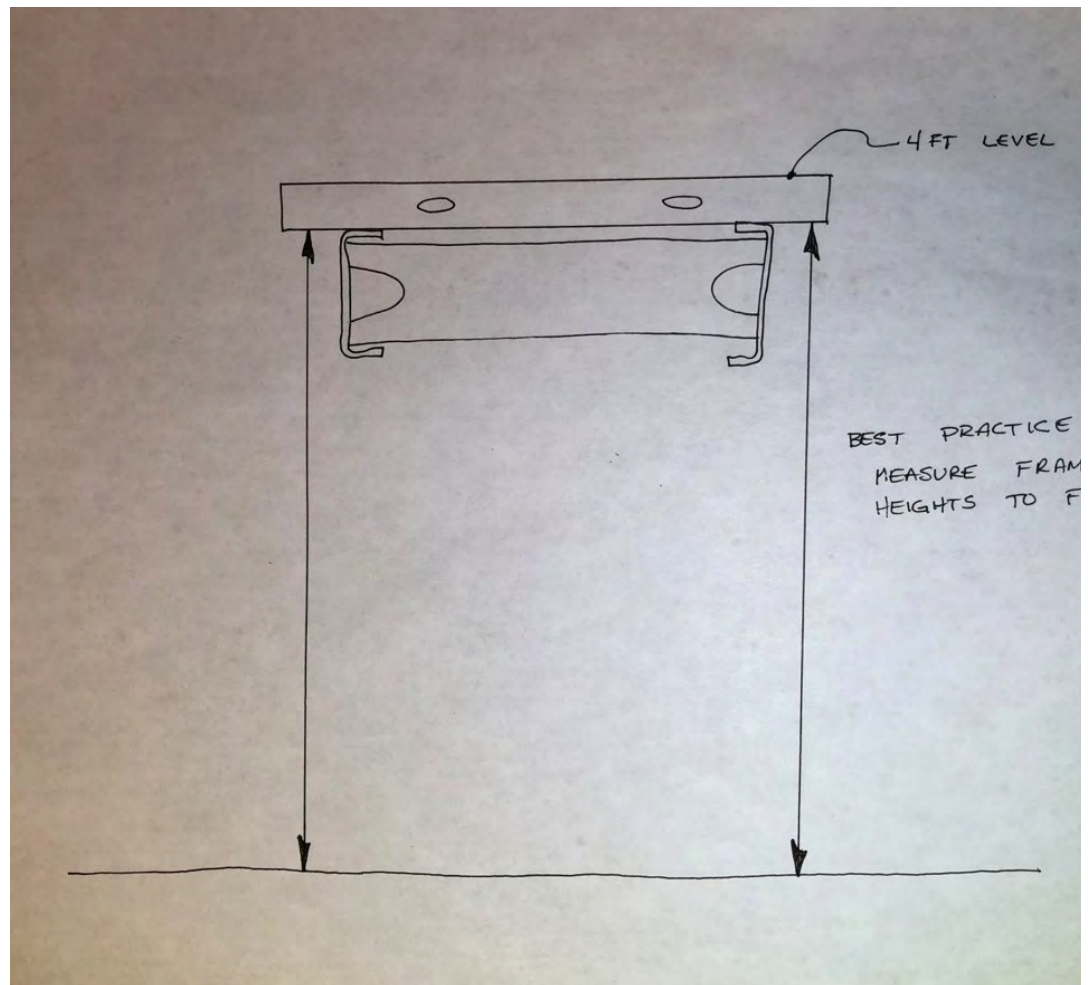

## Checking shop floor for level when measuring frame for level

Use the 4 ft level on the shop floor directly under the frame where you will be taking each measurement.

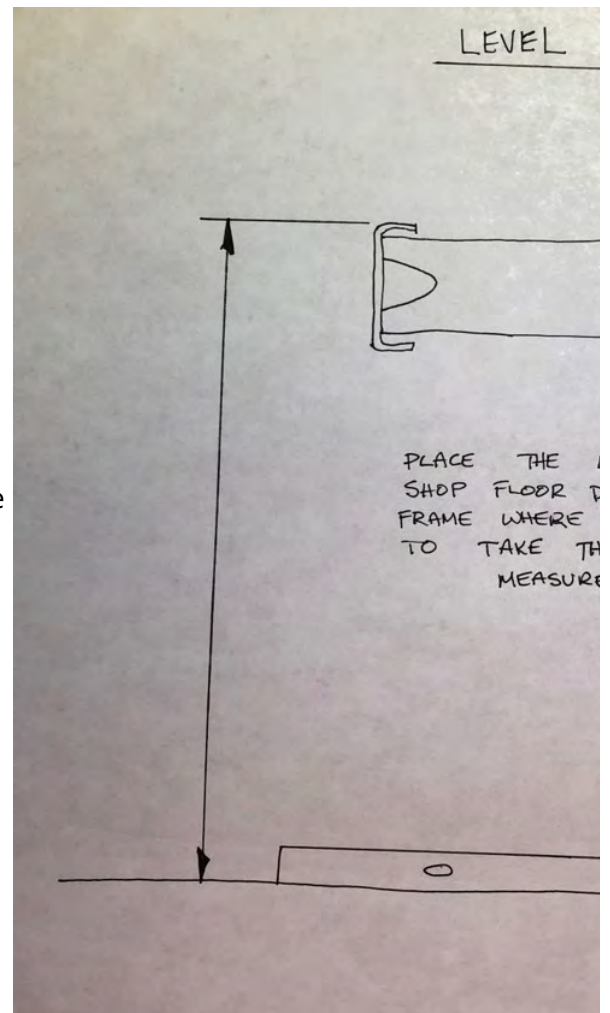

**Measuring frame height where a 4 ft level will not work.**

Use a smaller level or a torpedo level where the longer level will not work, i.e. engine compartment, front of frame.  
Again, check the shop floor at each measurement location.

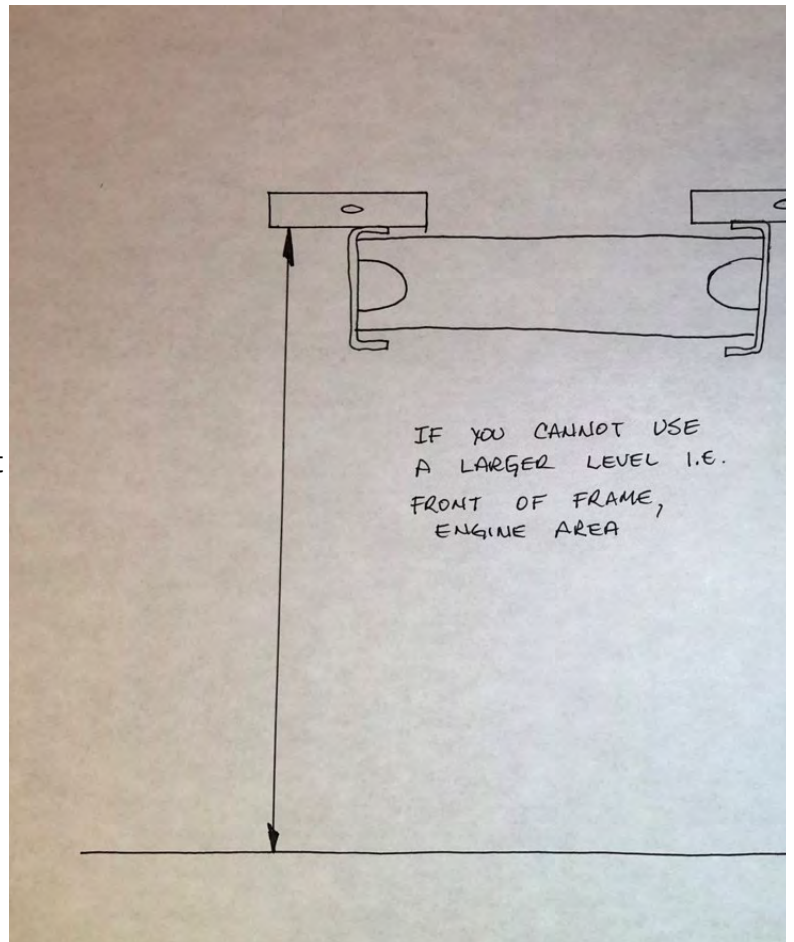

## Floor out of level at measurement location

Where the shop floor is NOT level, shim the 4 ft level and then subtract the difference from the measurement at that location specifically

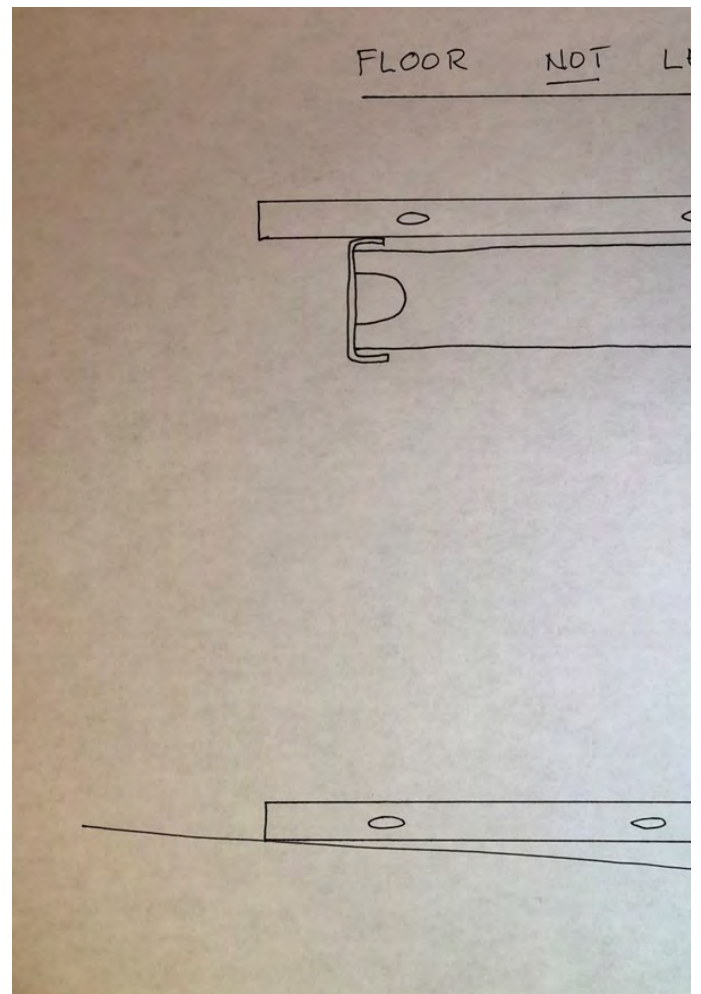

## Related links and attachments

[KC-2016 CHART PDF](#)



### Share

to others that might find it helpful



### Feedback

[Give feedback](#)

to help improve the content of this article

