

# Service Alert

Mazda North American Operations  
Irvine, CA 92618-2922



<b>Subject:</b>  RATTLE FROM SUNROOF AREA	<b>Service Alert No.:</b> SA-001/24
	<b>Last Issued :</b> 01/05/2024

## BULLETIN NOTES

This SA supersedes the previously issued service alert(s) listed below. The changes are noted in Red.

Previous SAs:	Date(s) Issued:
SA-014/23	11/14/23, 07/11/23, 03/20/23 and 03/10/23
SA-032/22	12/22/22 and 05/10/22

## APPLICABLE MODEL(S)/VINS:

2023-2024 CX-50

## DESCRIPTION

Some customers may report a rattle from the sunroof (panorama roof) area. Make sure to read the complete repair procedure before attempting any repairs as the sunroof may have rattles from more than one location. Customers having this concern should have their vehicle repaired using the following repair procedure.

## REPAIR PROCEDURE

Determine the vehicle type (A or B) by using the table below.

Vehicle Type	VIN Range	Side Cover Rattle	Cross Brace Rattle	Sunroof Unit
A	Up to production date 06/29/23.	Follow Procedure A	Follow Procedure B	Follow Procedure C
B	After 06/29/2023 production and up to 7MMVABEYXRN165681 (produced before 09/11/23)	Follow Procedure A	Contact Mazda Technical Hotline	Follow Procedure C
C	After 7MMVABEYXRN165681 (produced after 09/11/23)	Contact Mazda Technical Hotline	Contact Mazda Technical Hotline	Follow Procedure C

**CONSUMER NOTICE:** The information and instructions in this bulletin are intended for use by skilled technicians. Mazda technicians utilize the proper tools/ equipment and take training to correctly and safely maintain Mazda vehicles. These instructions should not be performed by "do-it-yourselfers." Customers should not assume this bulletin applies to their vehicle or that their vehicle will develop the described concern. To determine if the information applies, customers should contact their nearest authorized Mazda dealership. Mazda North American Operations reserves the right to alter the specifications and contents of this bulletin without obligation or advance notice. All rights reserved. No part of this bulletin may be reproduced in any form or by any means, electronic or mechanical--including photocopying and recording and the use of any kind of information storage and retrieval system ---without permission in writing.

**PROCEDURE A (FOR SIDE COVER RATTLE)**

The noise comes from the side cover vibrating against the assembly at the location marked by the arrow due to poor retention of the cover clips.

1. Test drive the vehicle and if you hear the noise, press the edges of the side covers (6 total) as shown in the example below.

**Was the noise eliminated?**

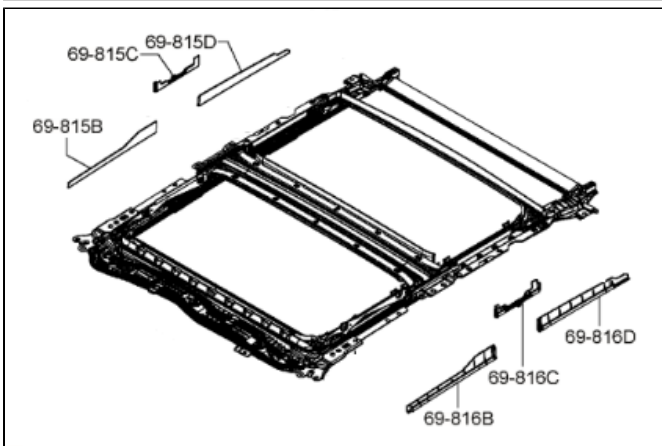

**YES:** Continue to the next step.

**NO:** Skip to the next section.

2. Order all 6 link covers and inspect them for non-woven felt.

**Do they have non-woven felt as shown in the image in step 3?**

**YES:** Go to step 4.

**NO:** Continue to the next step.

**CONSUMER NOTICE:** The information and instructions in this bulletin are intended for use by skilled technicians. Mazda technicians utilize the proper tools/ equipment and take training to correctly and safely maintain Mazda vehicles. These instructions should not be performed by "do-it-yourselfers." Customers should not assume this bulletin applies to their vehicle or that their vehicle will develop the described concern. To determine if the information applies, customers should contact their nearest authorized Mazda dealership. Mazda North American Operations reserves the right to alter the specifications and contents of this bulletin without obligation or advance notice. All rights reserved. No part of this bulletin may be reproduced in any form or by any means, electronic or mechanical---including photocopying and recording and the use of any kind of information storage and retrieval system ---without permission in writing.

3. Cut 4 pieces sized 5 mm x 15 mm x 0.4 mm and 4 pieces sized 10 mm x 10 mm x 0.4 mm out of the A-pillar felt, and then tape the cut pieces to the new link covers as shown in the image below.

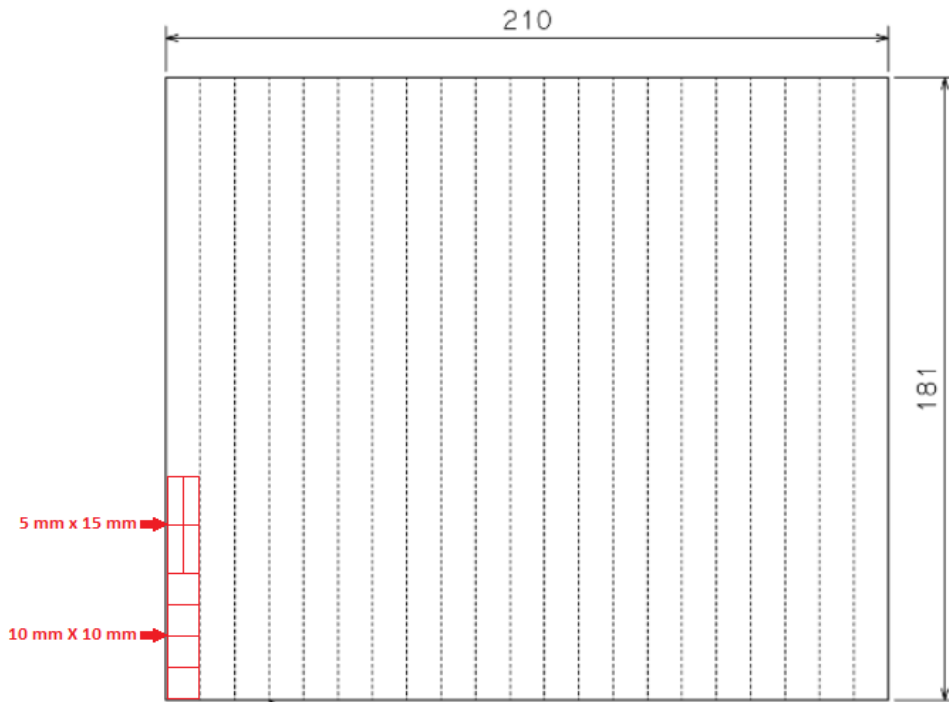

VAY1-68-2A3

FELT SHEET

SIZE : 210 x 181 x t0.5

QTY : 1

**CONSUMER NOTICE:** The information and instructions in this bulletin are intended for use by skilled technicians. Mazda technicians utilize the proper tools/ equipment and take training to correctly and safely maintain Mazda vehicles. These instructions should not be performed by "do-it-yourselfers." Customers should not assume this bulletin applies to their vehicle or that their vehicle will develop the described concern. To determine if the information applies, customers should contact their nearest authorized Mazda dealership. Mazda North American Operations reserves the right to alter the specifications and contents of this bulletin without obligation or advance notice. All rights reserved. No part of this bulletin may be reproduced in any form or by any means, electronic or mechanical---including photocopying and recording and the use of any kind of information storage and retrieval system ---without permission in writing.

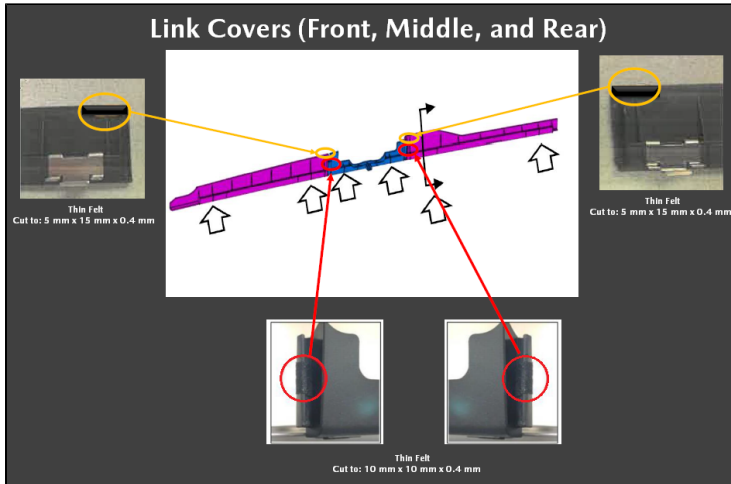

4. Replace all 6 link covers and retest for the rattle noise.

**PROCEDURE B (FOR CROSS BRACE RATTLE)**

The noise comes from the cross brace cover after the vehicle has been driven and the clips loosen. Follow the instructions below to eliminate the noise.

1. Refer to the attached video for a test procedure that does not require a test drive.

**Is there a rattle?**

**YES:** Continue to the next step.

**NO:** Skip to the next section.

2. Remove the rear glass panel using the SUNROOF REAR GLASS PANEL REMOVAL procedure.

3. Remove the pushpins and then remove the trim.

**CAUTION:** DO NOT damage the trim as it is only available with the sunroof assembly.



**CONSUMER NOTICE:** The information and instructions in this bulletin are intended for use by skilled technicians. Mazda technicians utilize the proper tools/ equipment and take training to correctly and safely maintain Mazda vehicles. These instructions should not be performed by "do-it-yourselfers." Customers should not assume this bulletin applies to their vehicle or that their vehicle will develop the described concern. To determine if the information applies, customers should contact their nearest authorized Mazda dealership. Mazda North American Operations reserves the right to alter the specifications and contents of this bulletin without obligation or advance notice. All rights reserved. No part of this bulletin may be reproduced in any form or by any means, electronic or mechanical--including photocopying and recording and the use of any kind of information storage and retrieval system ---without permission in writing.

4. Add noise reduction material from the Interior Noise Kit (see below) anywhere the trim makes contact with the frame.



5. Reassemble the trim in reverse order.

**NOTE:** Make sure the clips are ok and properly reinserted.

6. Reinstall the rear glass using the SUNROOF REAR GLASS PANEL INSTALLATION procedure.

7. Retest for the noise.

8. Test drive the vehicle.

**Do any rattling noises remain from the sunroof area?**

**YES:** Continue to the next section.

**NO:** Return the vehicle to the customer.

#### PROCEDURE C (FOR SUNROOF ASSEMBLY MOUNT POINTS)

1. Access the sunroof assembly mounting points using the relevant steps from the PANORAMA SUNROOF UNIT REMOVAL procedure.

2. Check the attaching hardware and ensure all nuts and bolts are tightened to specification. Refer to the PANORAMA SUNROOF UNIT INSTALLATION procedure for torque specs, the location of the hardware, and the relevant final assembly steps.

**Were all sunroof rattle noises resolved?**

**YES:** Return the vehicle to the customer.

**NO:** Continue to the next section.

**CONSUMER NOTICE:** The information and instructions in this bulletin are intended for use by skilled technicians. Mazda technicians utilize the proper tools/ equipment and take training to correctly and safely maintain Mazda vehicles. These instructions should not be performed by "do-it-yourselfers." Customers should not assume this bulletin applies to their vehicle or that their vehicle will develop the described concern. To determine if the information applies, customers should contact their nearest authorized Mazda dealership. Mazda North American Operations reserves the right to alter the specifications and contents of this bulletin without obligation or advance notice. All rights reserved. No part of this bulletin may be reproduced in any form or by any means, electronic or mechanical---including photocopying and recording and the use of any kind of information storage and retrieval system ---without permission in writing.

### SUNROOF UNIT

1. Remove the side cover at the front of the assembly to eliminate it as a possible noise source and for better access to the sunroof linkage.
2. Drive the vehicle with the sunroof open and confirm if a rattle is coming from the linkage in the general areas the red arrows point to.

**NOTE:** If you can reach the links that are rattling, you can hold them to confirm if the noise is eliminated.

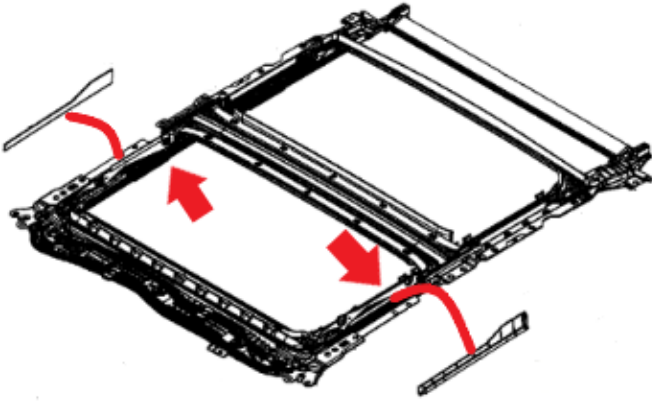

**Is there a noise from the linkage in this area?**

**YES:** Replace the sunroof unit.

**NO:** Create a video of the concern and then contact the Mazda Technical Assistance Hotline.

**CONSUMER NOTICE:** The information and instructions in this bulletin are intended for use by skilled technicians. Mazda technicians utilize the proper tools/ equipment and take training to correctly and safely maintain Mazda vehicles. These instructions should not be performed by "do-it-yourselfers." Customers should not assume this bulletin applies to their vehicle or that their vehicle will develop the described concern. To determine if the information applies, customers should contact their nearest authorized Mazda dealership. Mazda North American Operations reserves the right to alter the specifications and contents of this bulletin without obligation or advance notice. All rights reserved. No part of this bulletin may be reproduced in any form or by any means, electronic or mechanical---including photocopying and recording and the use of any kind of information storage and retrieval system ---without permission in writing.

**PARTS INFORMATION**

**NOTE:** If replacing any existing parts, use the GEPC with the VIN to look up parts to ensure they are the latest version and correct for that VIN.

Part Number	Description	Qty.	Notes
VAY1-68-2A3	A-Pillar Felt	1	VAY1-68-2A3 is considered a "shop supply" and bundled into the labor operation time since the kit repairs multiple vehicles.
VA45-69-830 - 75	Unit, Sunroof	1	This does not include glass.
<b>For Procedure A</b>			
VA 45-69-815	LINK COVER (R), FRONT	1	Only replace if directed by procedure A.
VA57-69-815	LINK COVER (R), REAR	1	
VA62-69-815	LINK COVER (R), CENTER	1	
VA57-69-816	LINK COVER (L), REAR	1	
VA45-69-816	LINK COVER (L), FRONT	1	
VA62-69-816	LINK COVER (L), CENTER	1	

**CONSUMER NOTICE:** The information and instructions in this bulletin are intended for use by skilled technicians. Mazda technicians utilize the proper tools/ equipment and take training to correctly and safely maintain Mazda vehicles. These instructions should not be performed by "do-it-yourselfers." Customers should not assume this bulletin applies to their vehicle or that their vehicle will develop the described concern. To determine if the information applies, customers should contact their nearest authorized Mazda dealership. Mazda North American Operations reserves the right to alter the specifications and contents of this bulletin without obligation or advance notice. All rights reserved. No part of this bulletin may be reproduced in any form or by any means, electronic or mechanical---including photocopying and recording and the use of any kind of information storage and retrieval system ---without permission in writing.