

SS 755 - WST X Series Odometer Reading Incorrect With Split Shaft PTO's

Applicable Vehicles

47X & 49X with split shaft PTO applications, Detroit Diesel engine & CEEA+ electrical architecture 2023 and prior.

Symptoms

Incorrect odometer readings with split shaft PTO is in operation.

Issue

On trucks with a Split Shaft PTO, the transmission output drive shaft rotates when the PTO is in use. When the truck is stationary (not driving), this is shown as a road speed on the speedometer and accumulates miles on the odometer, which is incorrect since the rear axle(s) are disconnected so the vehicle is not moving. This is not desirable as it can use up the customer's factory warranty, incur road taxes, and cause error indications since the ABS sensors show correctly that the truck is not moving.

Solution

Also, see alternate service solution SS750 for non tone ring revision.

The Detroit proprietary sensor will be used with a tone wheel installed after the SSPTO Transfer case so that when the driveline to the rear axles is disconnected the CPC will see zero vehicle speed even though the transmission output shaft is spinning to drive the PTO.

Installation

Factory wiring will be reconfigured and additional wiring and components will be added by the Truck Equipment Manufacturer as follows. Sourcing and installation of the hardware, wiring, and parameter changes will vary based upon the Transmission and SSPTO Transfer Case Brands that are currently or will be installed in the truck.

Hardware

Acquire and install a Tone Wheel and Speed Sensor Mounting Bracket on the axle side of the SSPTO Transfer Case.

NAMCOTM Transfer Cases

Driveline tone rings and Detroit sensor mounting brackets for several models of NAMCOTM transfer cases are available. Contact NAMCOTM directly to confirm availability of parts for your specific model. On some models an adapter collar is also required to mount the tone ring.

All other models

First, contact your transfer case manufacturer to determine if a tone wheel and sensor mounting bracket specific to the DetroitTM sensor are available. If no manufacturer solution is available this , a Tone wheel must be locally designed and sourced. The following is an example for use in developing your custom design.

Note 1: The picture below is for a 14-hole design. We recommend creating a 16-hole design since that is the default programmed number in the CPC5 software.

Note 2: The center hole pattern needs to be designed to match the driveline mounting bolts on the flange or yolk of the transfer case.

Note 3: A single piece tone wheel is preferred, but if your transfer case will require disassembly to install a single piece, a split tone wheel such as the one shown below is a better solution.

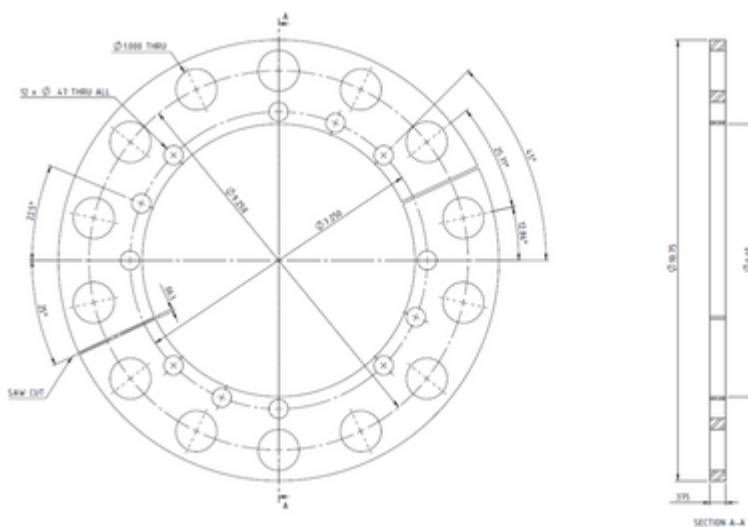

Example of a complete installed Tone Wheel is shown here:



Speed sensor mounting bracket requirements.

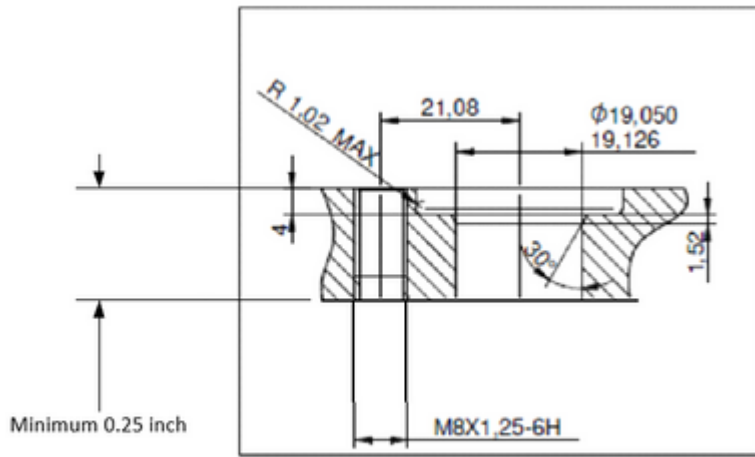

Sensor Mount Geometry

Speed Sensor

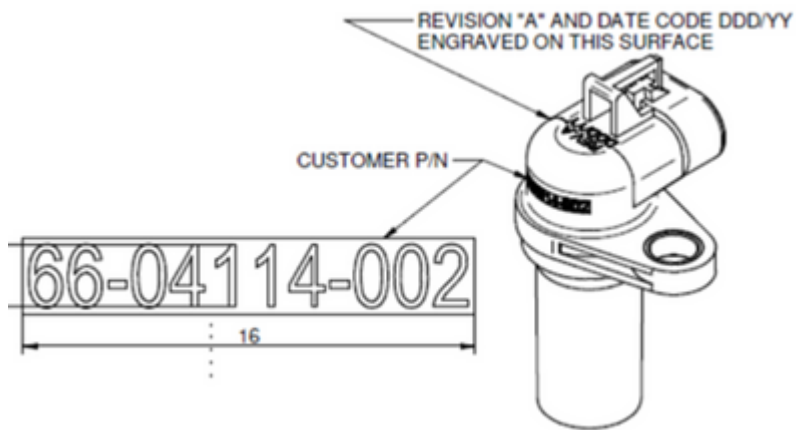

Sensor Alignment

The center of the sensor must align with the center of the hole in the tone wheel during rotation.

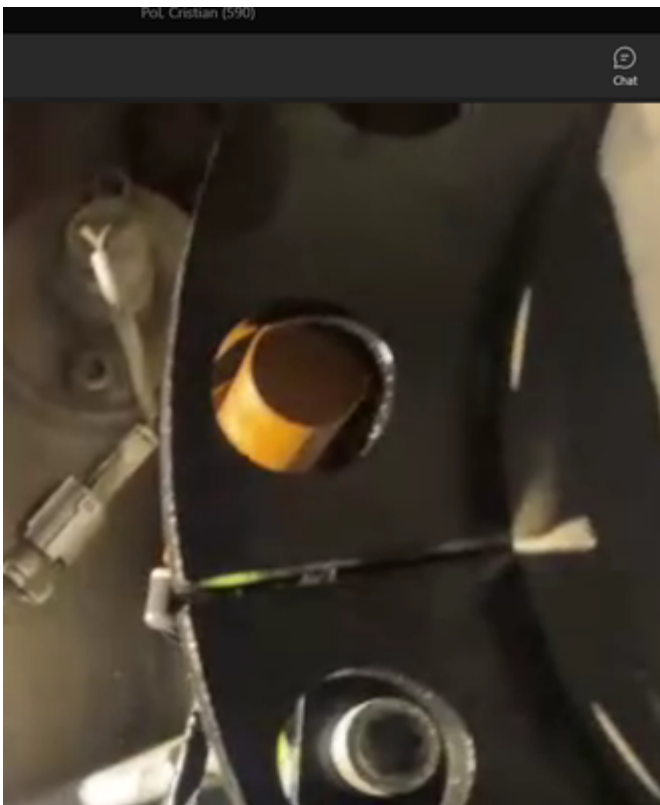

The sensor must not come in contact with the tone wheel.

The face of the sensor must be parallel to the face of the tone wheel.

The sensor gap must be maintained throughout the rotation of the tone wheel at 0.050 inches +/- 0.010 inches.

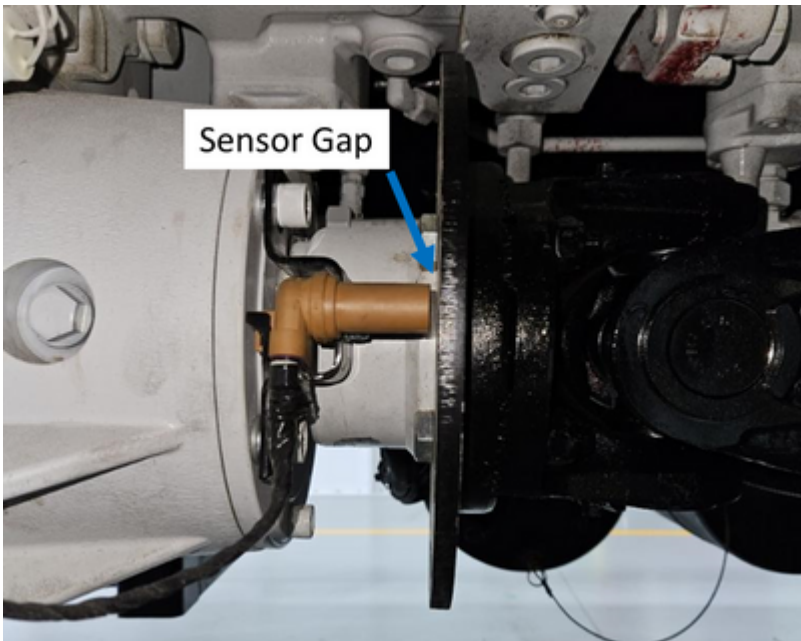

Wiring

Create a new wiring harness from the CPC5 to Detroit Vehicle Speed Sensor at the new location in the output of the split-shaft transfer case as shown in the diagram below:

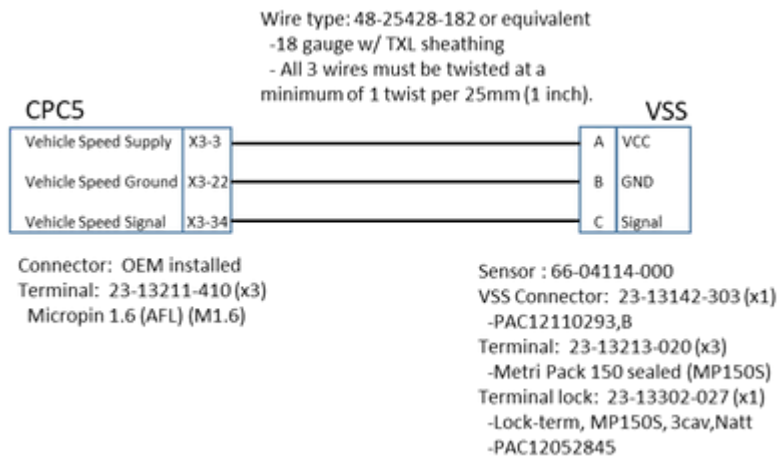

Programming

For the Eaton manual transmission no change to the CPC5 programming is required, but with an Allison transmission, the CPC5 is factory programmed to read the J1939 speed signal from the Allison TCM. The CPC must be reconfigured to use a wired sensor signal.

For these instructions, speed sensing is configured like a manual transmission. The speed signal is routed to the CPC to make calculations to determine vehicle speed when the vehicle is moving. When the vehicle is stationary the speed signal will show zero since the driveline to the rear axles will not be rotating.

Verify parameters in CPC5 are set as follows using Detroit™ Diagnostic Link software configuration tool:

1. Axle Ratio

1. 233-Powertrain Configuration Axle Ratio

- 1. Rear Axle Ratio 1 of 2 Verify axle ratio is set
- 2. Rear Axle Ratio 2 of 2 Verify axle ratio is set

2. Vehicle Speed Sensor

1. 330 - Vehicle Speed Sensor

- 1. Tire Revs per unit distance Set to value for the tires
- 2. Vehicle Speed Sensor = OutputshaftSpeed hall sensor
 average

2. Teeth per gear

1. 11 - Vehicle Configuration

- 1. cdi_pVehConf.TissTeethNum_u8 = Number of holes on the
 tone wheel

If your tone wheel has 16 teeth, setting this parameter is not necessary since this is the default setting in the CPC5. If your tone wheel has a different number of holes, a call to the Detroit Customer Assistance Center is required in order to complete this step.

Labels :



Add tags



Comment