

IMPORTANT SET-UP NOTICE

POST IN A PROMINENT LOCATION

XR650L Oil Pressure Inspection

The oil pump on XR650L units may not be primed from the factory. The lack of priming will cause the pump to malfunction and lead to **no oil pressure** and subsequent lack of lubrication/cooling. This, in turn, could lead to **engine seizure**.

Before starting the engine of any XR650L during the *Check the oil level* procedure in the *Set-Up Instructions* (step 23, page 14), you **MUST** check the oil pressure.

Follow the *Check the oil level* procedure in the *Set-Up Instructions* to verify there is oil in the engine/oil tank. Then, before starting the engine, check the oil pressure by following the procedure described below.

1. Loosen the oil line fitting at the cylinder head enough to break the seal of the banjo bolt.
2. Turn the engine stop switch to the **OFF** position.
3. Crank the engine with the electric starter for **up to 30 seconds**.
 - If **oil seeps** from the oil line fitting, the oil pump is **working correctly**. Tighten the oil line fitting (see torque setting below*) and proceed with the oil check procedure.
 - If **no oil seeps** from the oil line fitting, the oil pump is **not working correctly** and it will need to be primed. If so, leave the oil line fitting loose and follow the priming procedure described below:
4. Remove the oil filler cap/dipstick from the frame oil tank and insert a suitable rubber plug (see below for suggestion**) to seal the oil filler hole and allow compressed air to be introduced.
5. Turn the engine stop switch to the **OFF** position.
6. Crank the engine with the electric starter while applying compressed air to the oil tank. When oil begins to flow from the oil line fitting, stop blowing the compressed air but continue to crank the engine a few more times to ensure that oil continues to flow.
7. Tighten the oil line fitting and continue with the *Check the oil level* procedure in the *Set-Up Instructions*.

*Oil line fitting torque: **18 N·m (1.8 kgf-m, 13 lbf-ft)**

** Tapered SBR Rubber Plug, size 1, P/N: 9545K26.

Order from McMaster-Carr at (330) 342-3330.

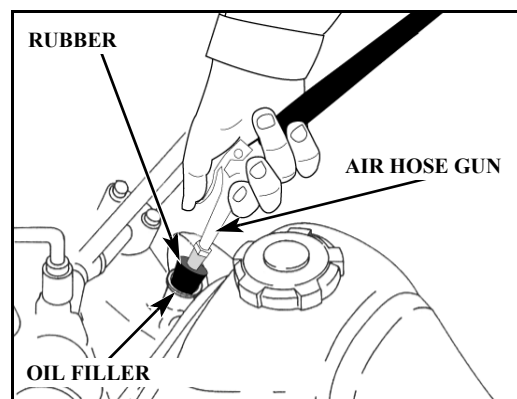
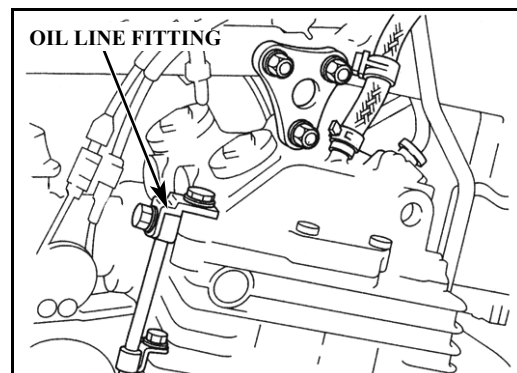

Please make sure that all relevant dealer personnel are aware of this information.