

2024-01-08

This Service Information Bulletin (Revision 6) replaces SI B54 11 19 **dated March 2023**.

What's New (Specific text highlighted):

- Models added.
- New/updated information in attachment 2.

<input type="checkbox"/>	THIS REPAIR IS MOBILE FRIENDLY
--------------------------	--------------------------------

MODEL

F95 (X5 M Sports Activity Vehicle)	F96 (X6 M Sports Activity Coupe)	F97 (X3 M Sports Activity Vehicle)	F98 (X4 M Sports Activity Coupe)
G01 (X3 Sports Activity Vehicle)	G02 (X4 Sports Activity Coupe)	X5 (Sports Activity Vehicle)	X6 (Sports Activity Coupe)
X7 (Sports Activity Vehicle)			

SITUATION

This bulletin outlines known areas of possible water entry, operational noise, or wind noise for the vehicles listed above. It serves only as a diagnostic resource in troubleshooting complaints from the roof area.

This bulletin and the associated attachments are designed to provide one single diagnostic resource for troubleshooting all known issues related to the panoramic sunroof of BMW Sports Activity Vehicles which have quality improvement measures already in place.

CAUSE

The attached diagnostic resource provides repair instructions to over 30 potential causes related to water entry, operational noise, or wind noise.

CORRECTION

Utilize the attached diagnostic troubleshooting document based on the customer complaint.

Note: The diagnostic troubleshooting document is interactive. For each set of customer complaints (water leak, wind noise, static noise, function noise) an overview page will be displayed showing the areas of potential concern related only to the customer complaint. Clicking the applicable links will bring the technician to specific areas to investigate and repair.

For clarification:

- Water leak would be water entry into the vehicle from the sunroof area
- Wind noise would be excessive noise entry into the vehicle while driving
- Static noise would be noises heard while driving, typically over rough road surfaces
- Function noise would be noises heard while operating the sunroof glass or roller sunshade

SUNROOF DIAGNOSIS

WHAT IS THE ISSUE?

Water Leak



Select troubleshooting steps by clicking the applicable option

Wind Noise

Static Noise

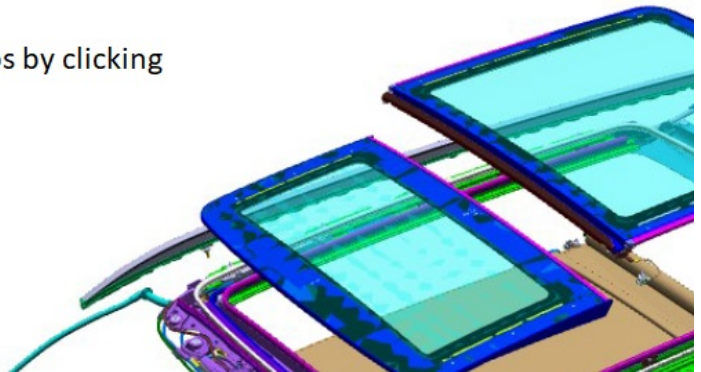

POSSIBLE CAUSES- CLICK CAUSE FOR ADDITIONAL INFORMATION

Click the possible causes

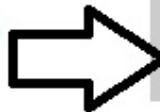

Front Center Seal
Front center seal loose/shrinking

Drain Tubes

Not connected to sunroof
Twisted/Kinked
Not connected at bottom
Clogged with dirt/debris

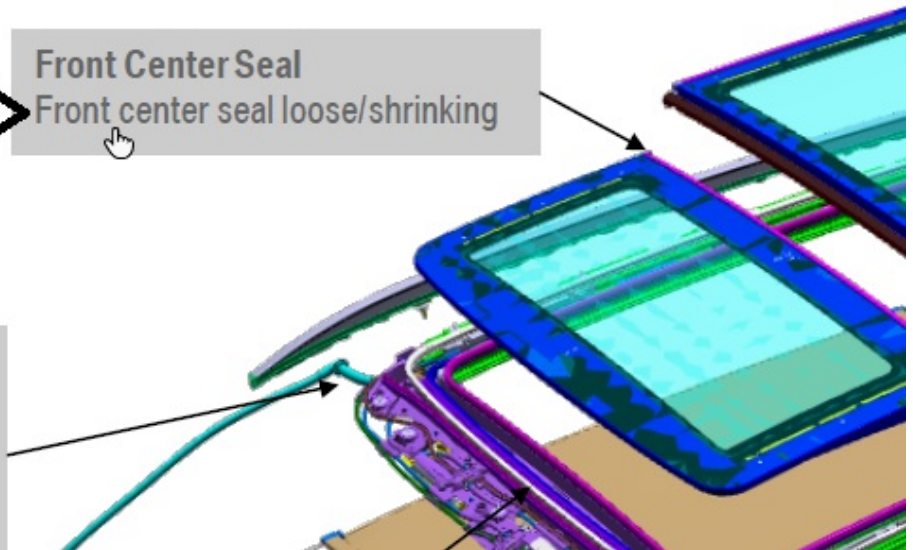

PROCEDURE

Each slide is accompanied by a suggested diagnostic troubleshooting method and a repair suggestion.

Note: **For any vehicle where a defect is found that is NOT included in the diagnostic troubleshooting document, a TSARA INFO case must be submitted providing feedback/photos when possible of the defect so that product quality improvements and diagnostic resources such as this can continue to be developed.**

- **If the vehicle cannot be diagnosed using the troubleshooting document and additional diagnostic assistance is required or additional information is needed on any issue in the document, a TSARA reply requested case should be submitted.**

Please reference the exact issue found in the technician warranty notes (“the story”) so that we can continue to compare your findings against the quality improvements which we have in place. The title of the slide related to the issue that was found should be included in the technician notes for reference.

PARTS INFORMATION

Required parts will depend on the specific repair that is necessary. This bulletin only serves as a diagnostic resource. Refer to FTK/AIR if parts are required for repair.

Copyright ©2024 BMW of North America, Inc.

WARRANTY INFORMATION

Warranty defect code and labor operations will depend on the specific repairs made to each vehicle. This bulletin only serves as a diagnostic resource.

Repairs which are eligible for warranty coverage should be claimed for using the applicable defect code and labor operations found in AIR.

QUESTIONS REGARDING THIS BULLETIN



Technical inquiries	Submit feedback at the top of this bulletin
Warranty inquiries	Submit an IDS ticket to the Warranty Department or use the chat available in the Warranty Documentation Portal
Parts inquiries	Submit an IDS ticket to the Parts Department

Supporting Materials

[picture_as_pdf B54 11 19_Attachment 1.pdf](#)

[picture_as_pdf B54 11 19_Attachment 2.pdf](#)

Note: Appropriately sized plastic inserts will need to be sourced locally.

	<ul style="list-style-type: none"> Place the plastic insert inside the drain tube, as shown.
	<ul style="list-style-type: none"> Roll back the drain tube and apply a piece of butyl between the plastic insert and the tube. Note: The butyl must wrap completely around the insert.
	<ul style="list-style-type: none"> Unroll the drain tube and apply a tie wrap over the drain tube in the area of the butyl and the insert. The tie wrap must be installed in the orientation shown. This will eliminate any possible interference when the headliner is reinstalled.
	<ul style="list-style-type: none"> Install the tube with the plastic insert into the other end of the drain tube and perform the same connection procedure with butyl and tie wrap.

SUNROOF DIAGNOSIS

WHAT IS THE ISSUE?

Water Leak

Wind Noise

Static Noise

Function Noise

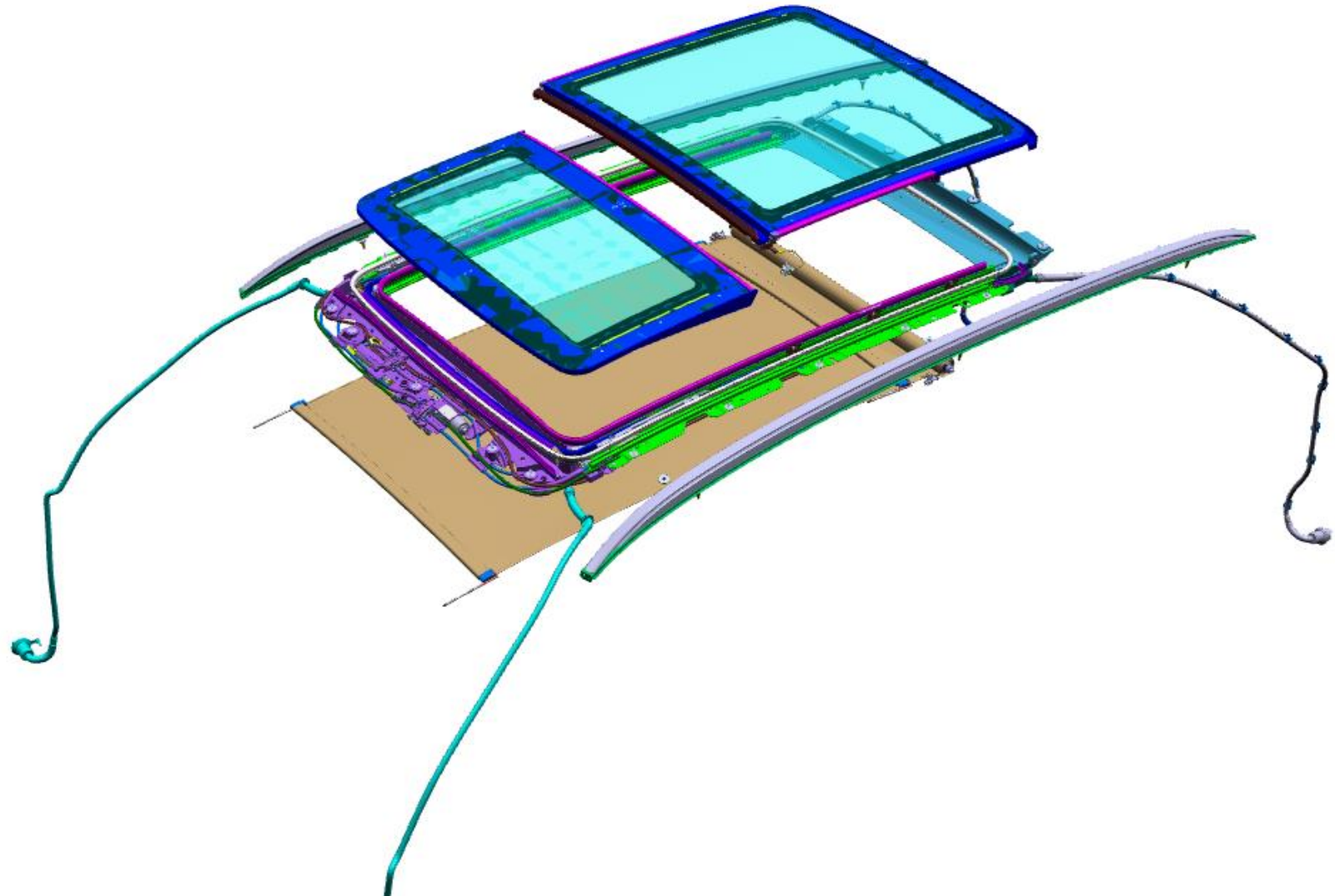

WATER LEAKS

POSSIBLE CAUSES- [CLICK CAUSE FOR ADDITIONAL INFORMATION](#)

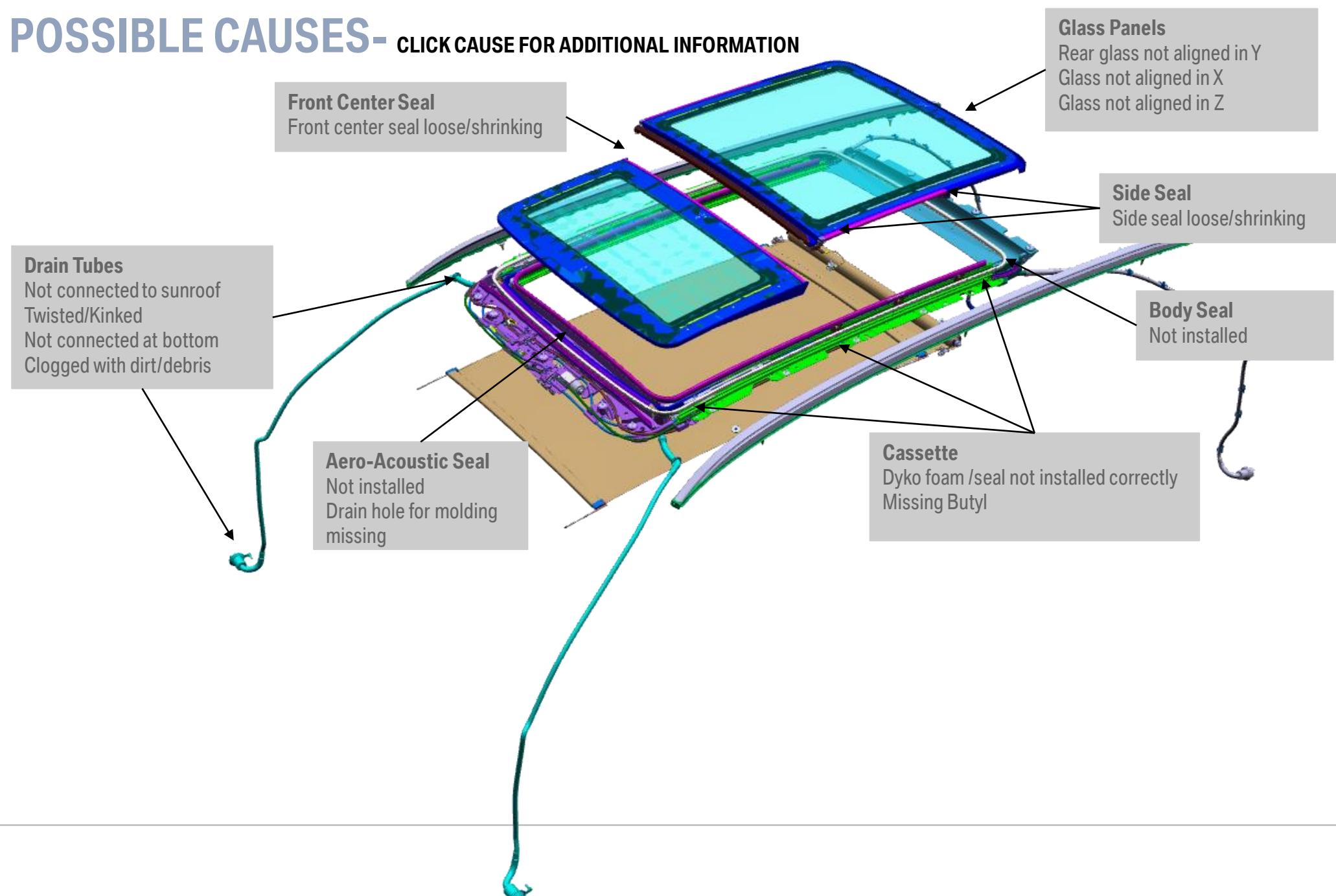

FRONT CENTER SEAL LOOSE/SHRINKING

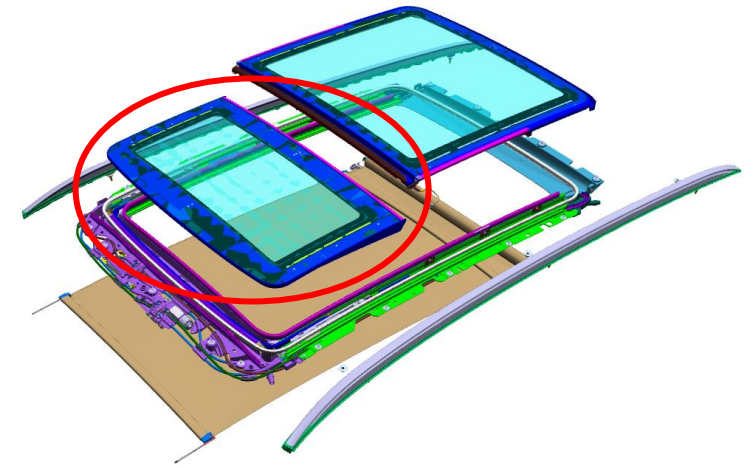
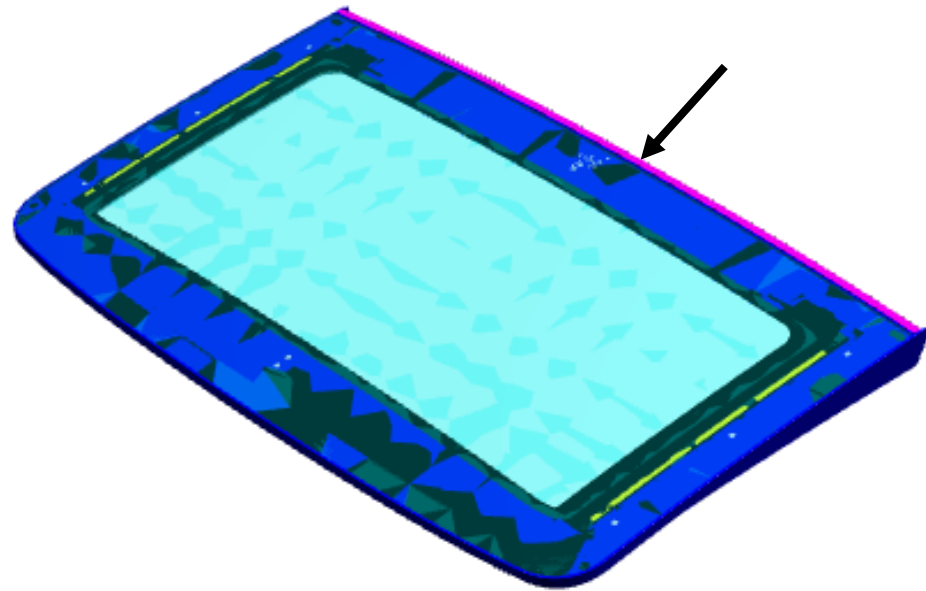

Defect: separated



Defect: shrunken / gap

Situation: Excessive water enters through the sunroof seals.

Repair: Look for gap near end of the seal on front glass. If found, replace seal according to ISTA/AIR instructions REP 54 13 052. Also refer to B54 04 21.



SIDE SEAL LOOSE/SHRINKING

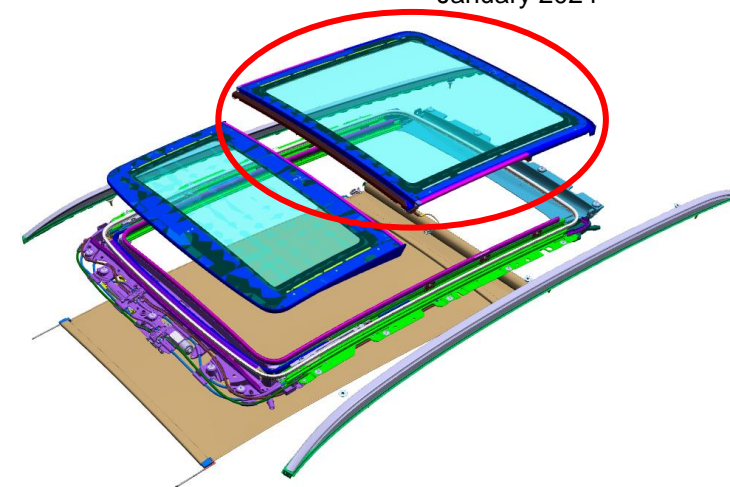
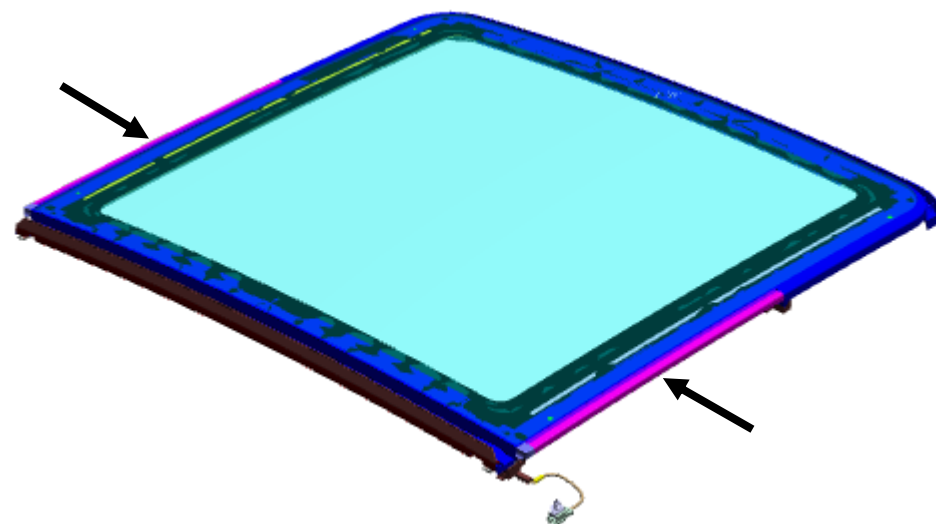

Situation : Excessive water enters through the sunroof seals. (see pictures)

Repair: Look for gap near ends or twist in seal. If found, replace seal according to ISTA/AIR instructions.
REP 54 13 050



Defect: gap



Defect: twist



Defect: loose

BODY SEAL NOT ATTACHED

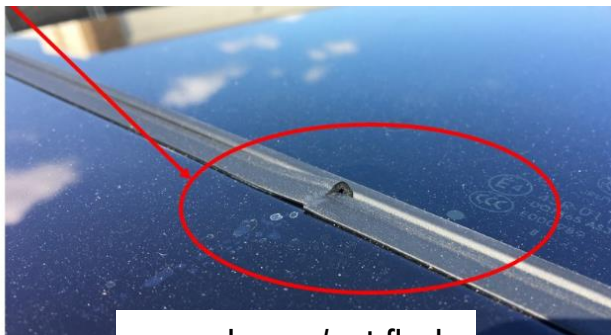
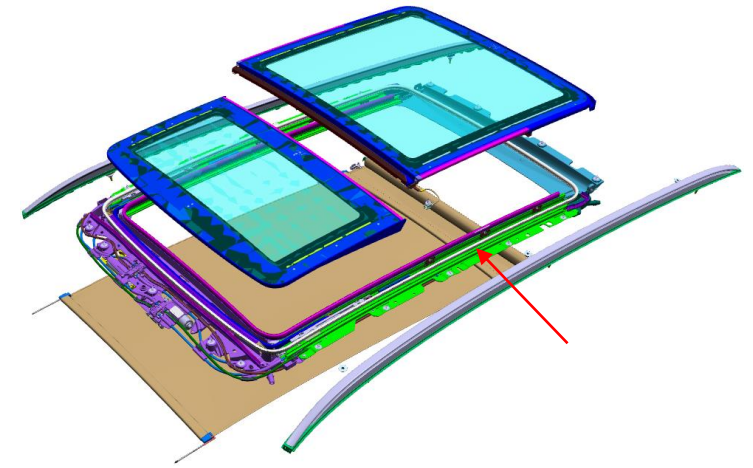
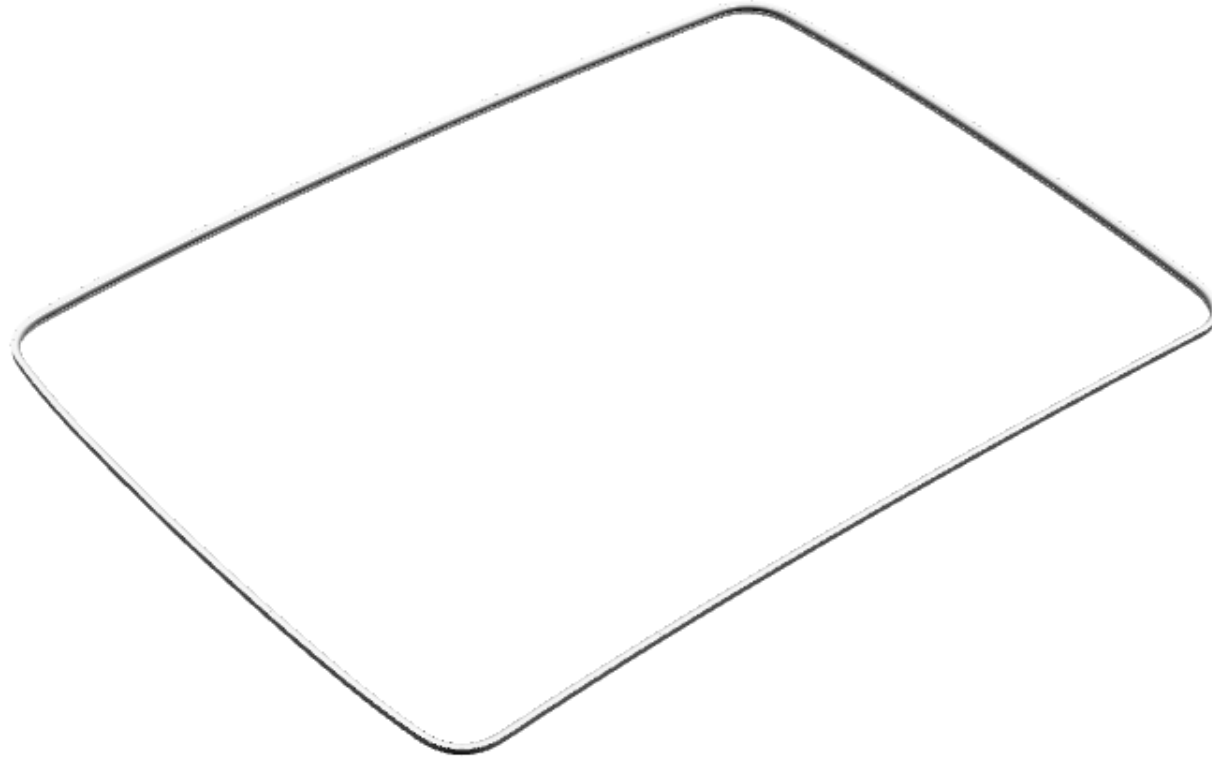

example: gap/not flush

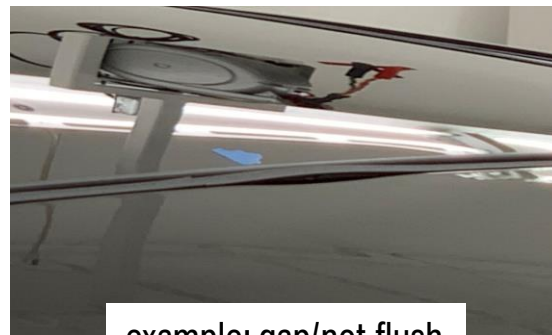

example: gap/not flush

Situation : Excessive water enters through the sunroof seals.

Repair: Inspect the sunroof perimeter seal for defects. Replace body seal according to ISTA/AIR instructions REP 54 13 055.



DYKO FOAM/SEAL- WATER INTRUSION INTO DRY SIDE OF CHANNEL

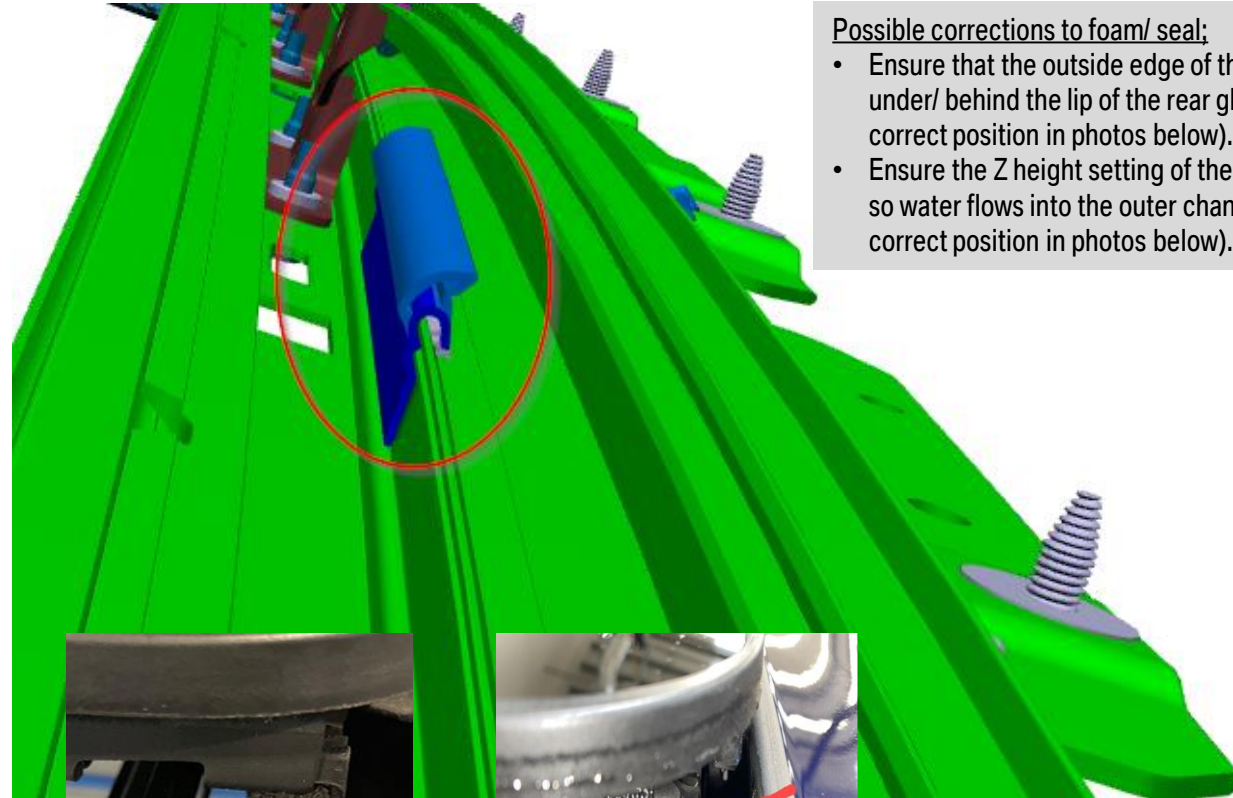

Possible corrections to foam/ seal;

- Ensure that the outside edge of the foam/ seal is tucked under/ behind the lip of the rear glass drain channel. (See correct position in photos below).
- Ensure the Z height setting of the rear glass panel is correct so water flows into the outer channel of the cassette. (See correct position in photos below).

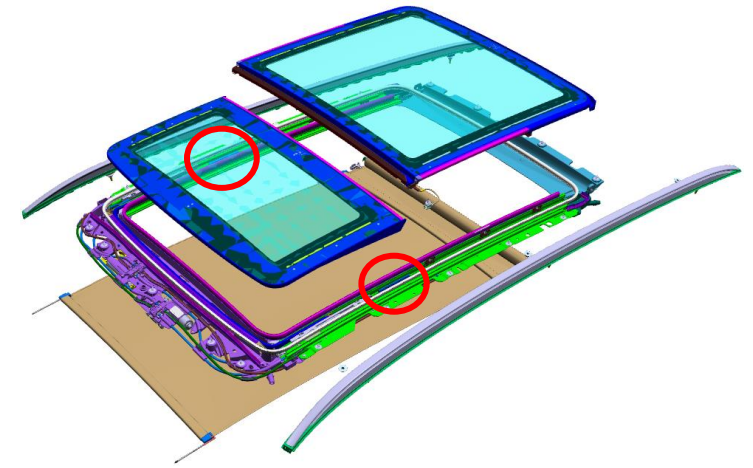

Solution: If there is a water leak near the middle drain channel, check position of the seal and foam.

Production before March 26 2020:	foam (a)
Production after March 26 2021:	seal (b)
Production in between:	no foam/seal

(!) If NO foam/seal is present, the root cause of a water leak is NOT the foam/seal. Missing foam/seal will NOT CAUSE A WATER LEAK!! DO NOT REPLACE THE FFRAE FOR THIS.

Repair: Check position of the seal/ foam. Remove foam/ seal if deformed or damaged.

Part Number: 9466049-02, if new rubber seal is not available it is approved to use the foam for repair.



Correct foam position (a)

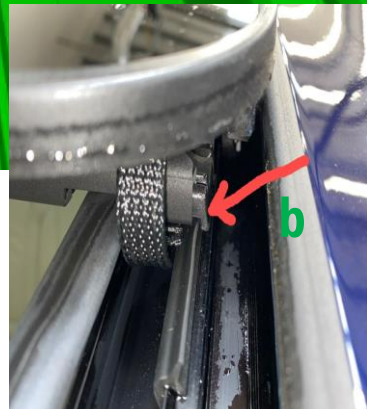

Correct seal position (b)



MISSING BUTYL BETWEEN SIDE GUIDES AND BEAM

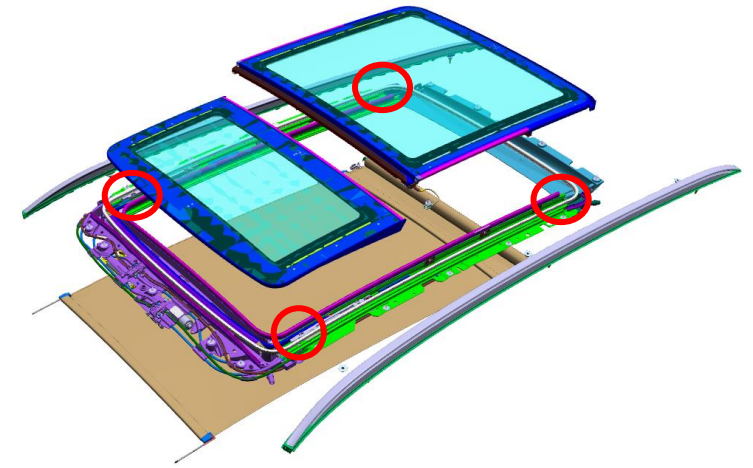
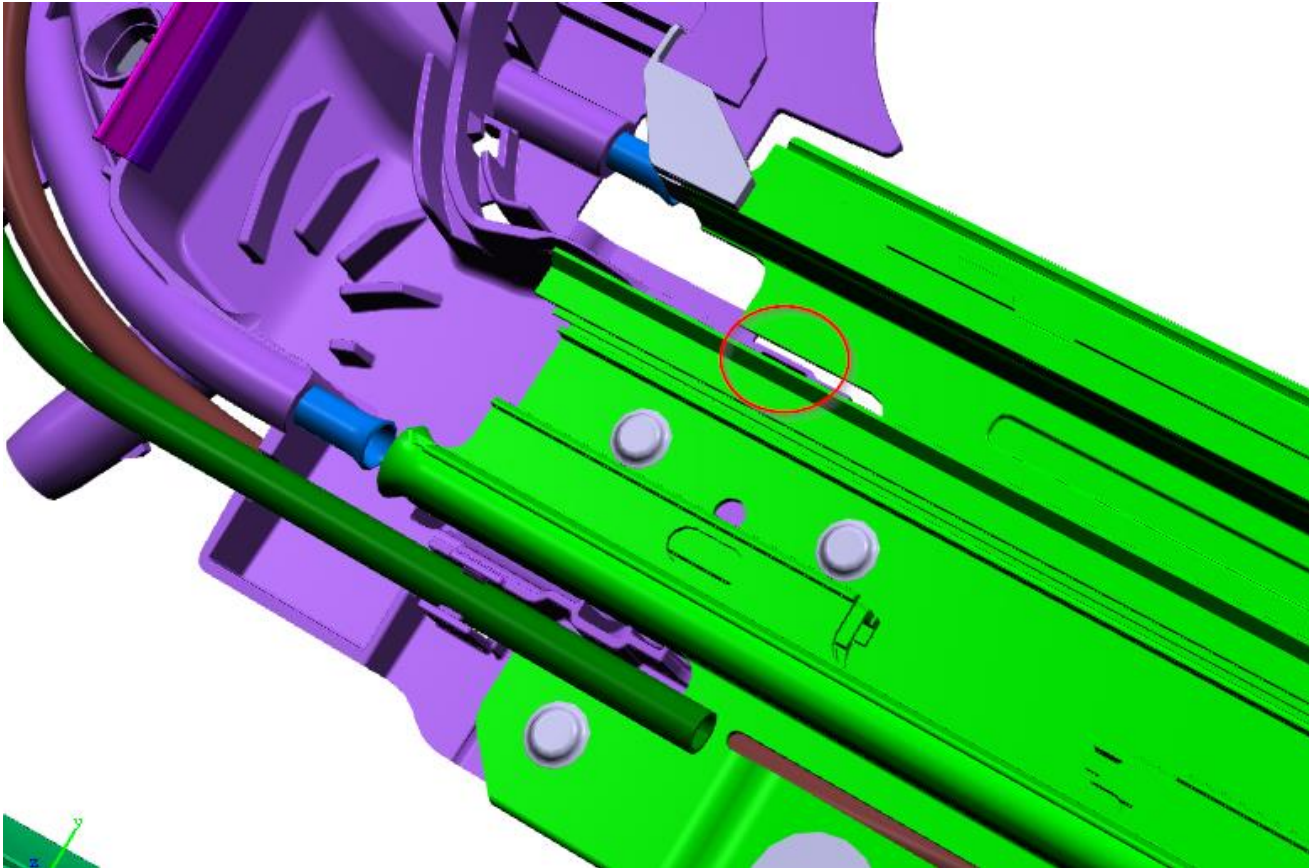

Situation : There is a water leak running between front/rear beam and side guide.

Repair: There may be missing butyl sealer. ENSURE ALL OTHER WATER MANAGEMENT (SEALS, DRAINS) ARE CHECKED FIRST. ENSURE PROPER WATER TESTING PROCEDURES ARE BEING FOLLOWED (DO NOT OVERFLOW THE SEALED TRACK)

Replace frame according to ISTA/AIR instructions REP 54 13 261.



REAR GLASS NOT ALIGNED LEFT TO RIGHT (Y)

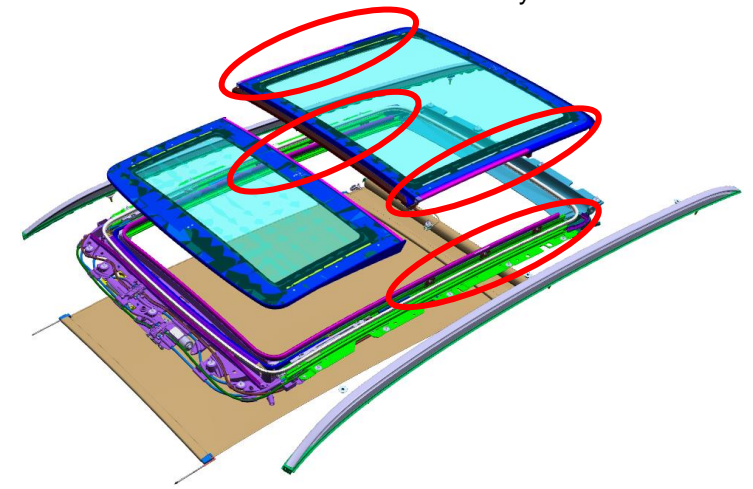
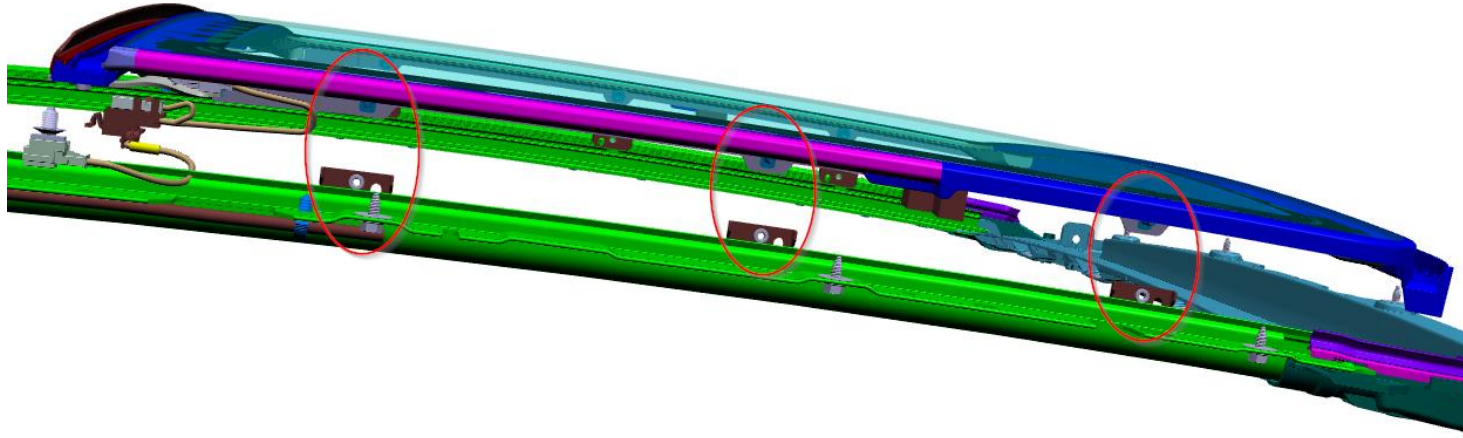

Situation: Excessive water enters a gap between the side seals and body.

Repair: Check the seals. If seals are OK, check left to right alignment of rear glass (minimal adjustment possible).

Adjust the rear sunroof glass and recheck left to right adjustment. Potential adjustment is very minor. If issue persists then replace frame according to ISTA/AIR instructions REP 54 13 261.



FRONT/REAR GLASS NOT ALIGNED IN X

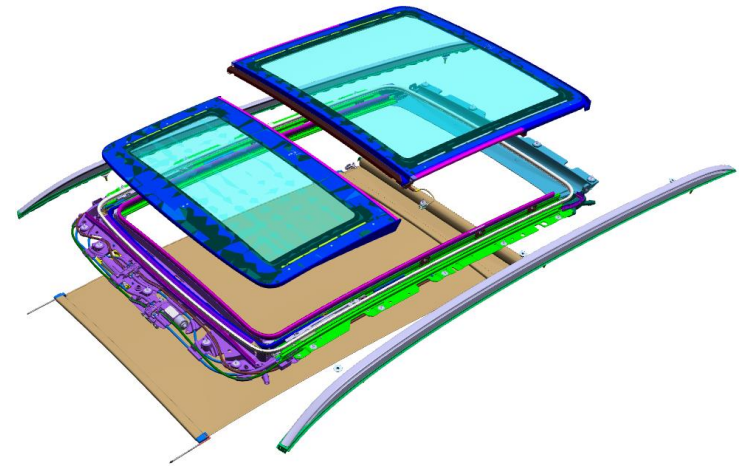
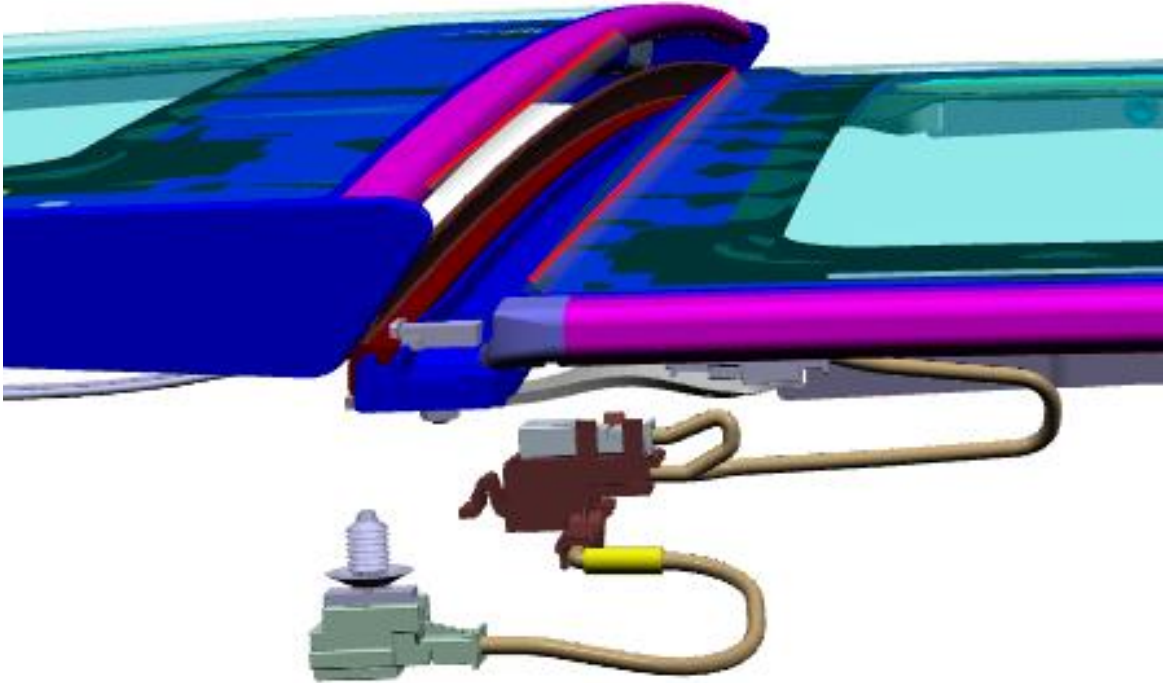

Situation: Excess water enters the perimeter of the glass. Front and/or rear glass panels misadjusted front to rear.

Repair: Adjust both sunroof glass panels according to ISTA/AIR instructions REP 54 13 002.



FRONT/REAR GLASS NOT ALIGNED IN Z

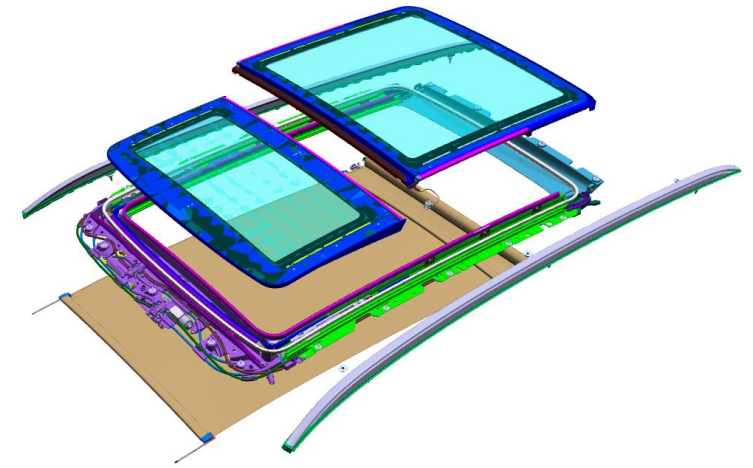
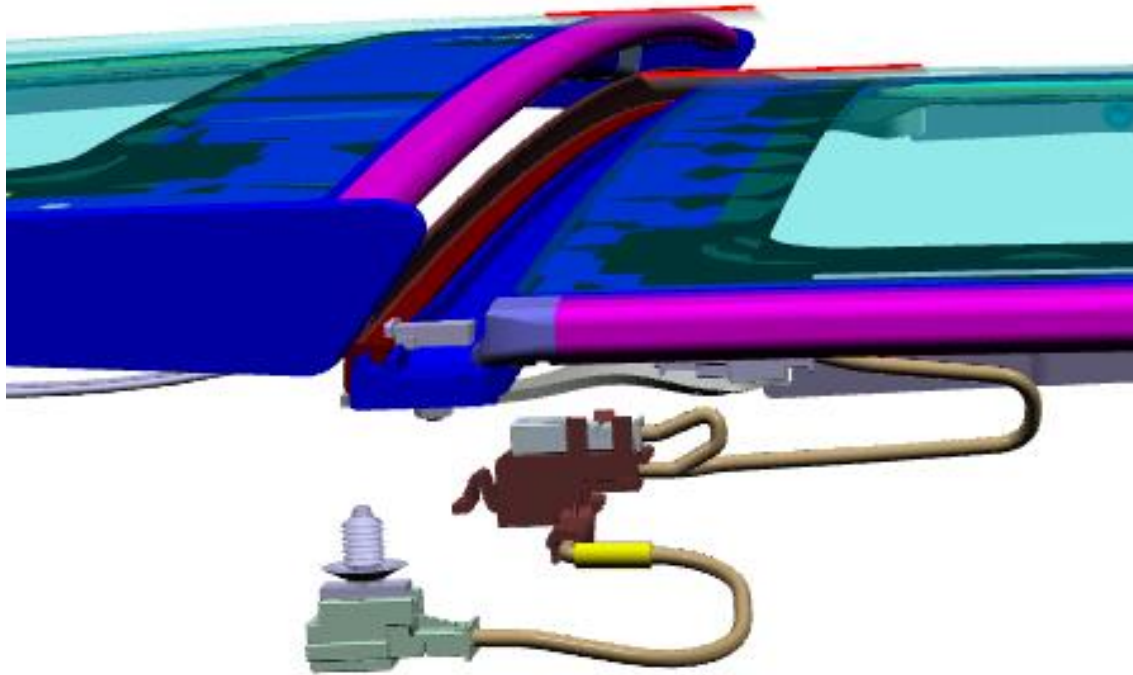

Situation: Excess water enters between the glass panels. Front and/or rear glass panel height misadjusted.

Repair: Adjust both sunroof glass panels according to ISTA/AIR instructions REP 54 13 002.



DRAIN TUBE NOT CONNECTED AT TOP

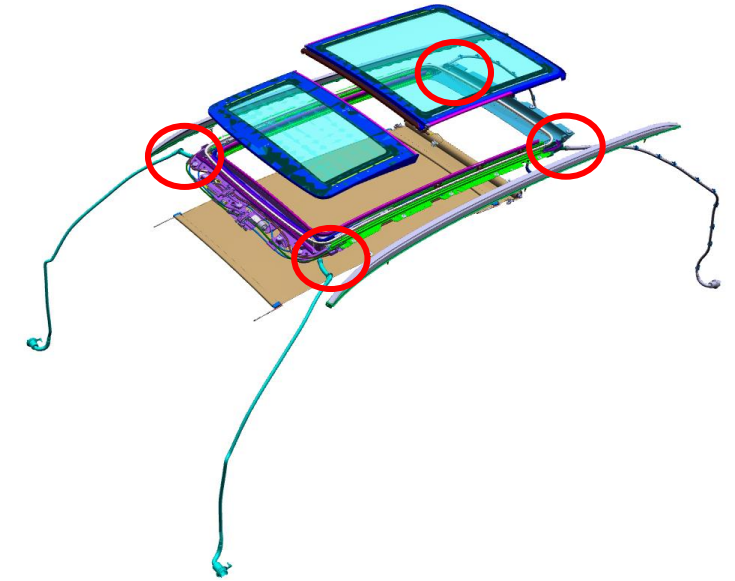
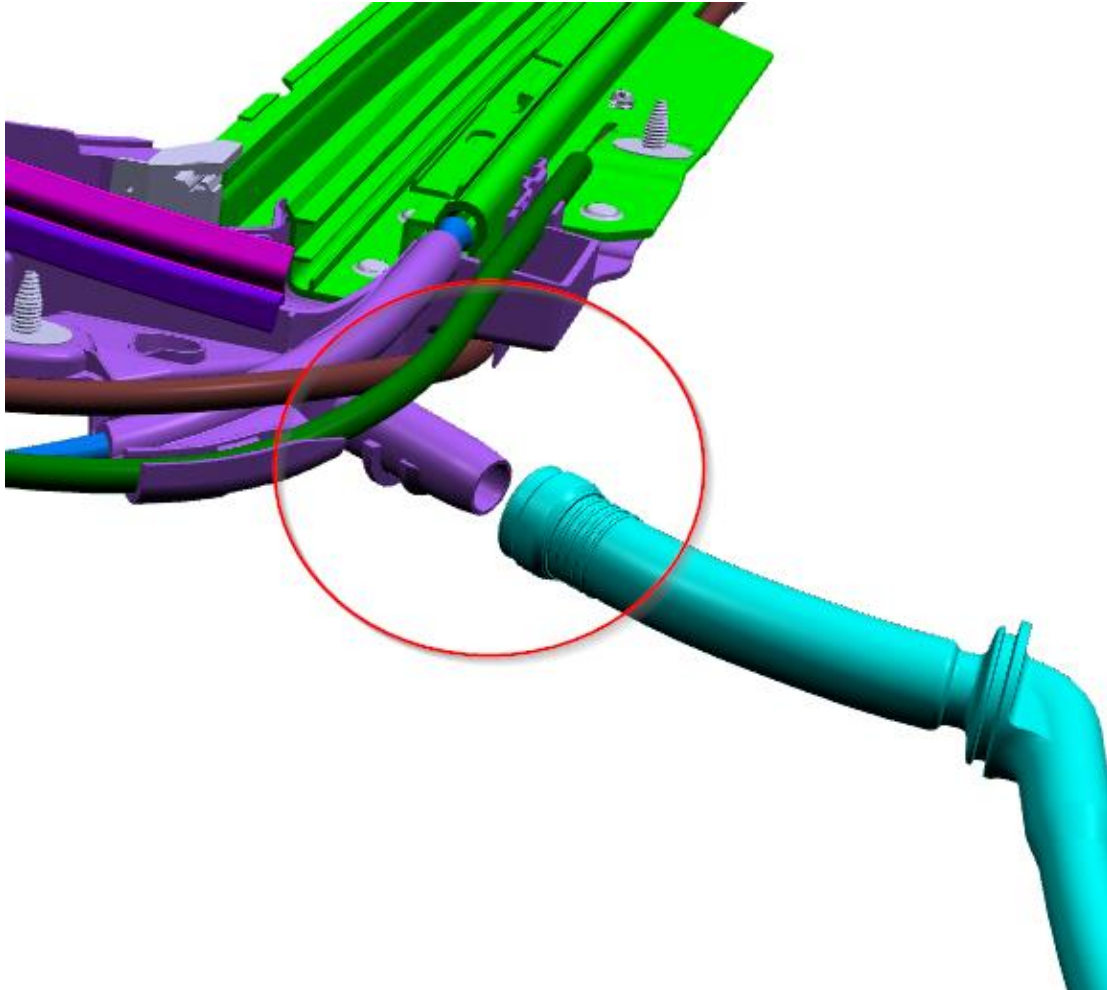

Situation: There is a water leak near the trunk area or you have a water leak near the front carpets. The drain tubes may not be properly connected at the sunroof frame (the top).

Repair: Check the drain tube connections at the sunroof. Reconnect if necessary.



FRONT DRAIN TUBE TWISTED/KINKED

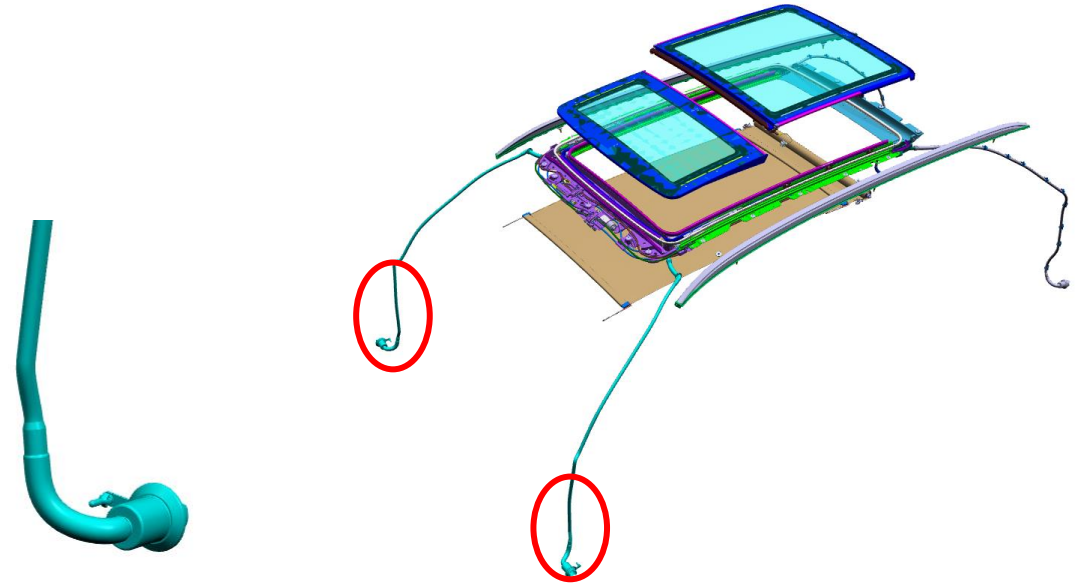

twisted



kinked



Slightly kinked



Situation: There is a water leak near the front or rear carpets. The drain tubes may be twisted. Remove A-pillar kick panels to check if front drain tube is twisted/kinked. Use borescope if needed.

Repair: Reposition hose to remove kink. If kink can't be removed, refer to B54 11 19 Attachment 1 for repair instructions.

!!This situation is one of the more common issues. Investigate thoroughly!!



DRAIN TUBES NOT CONNECTED AT BOTTOM

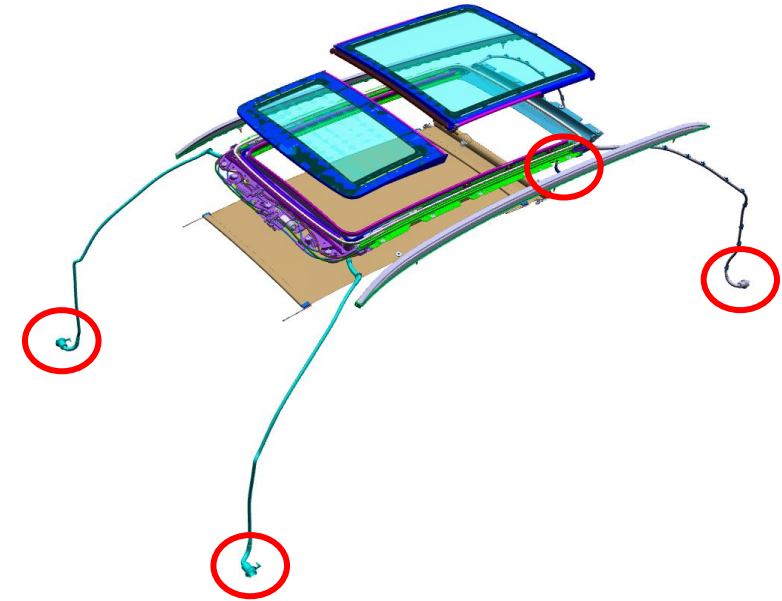
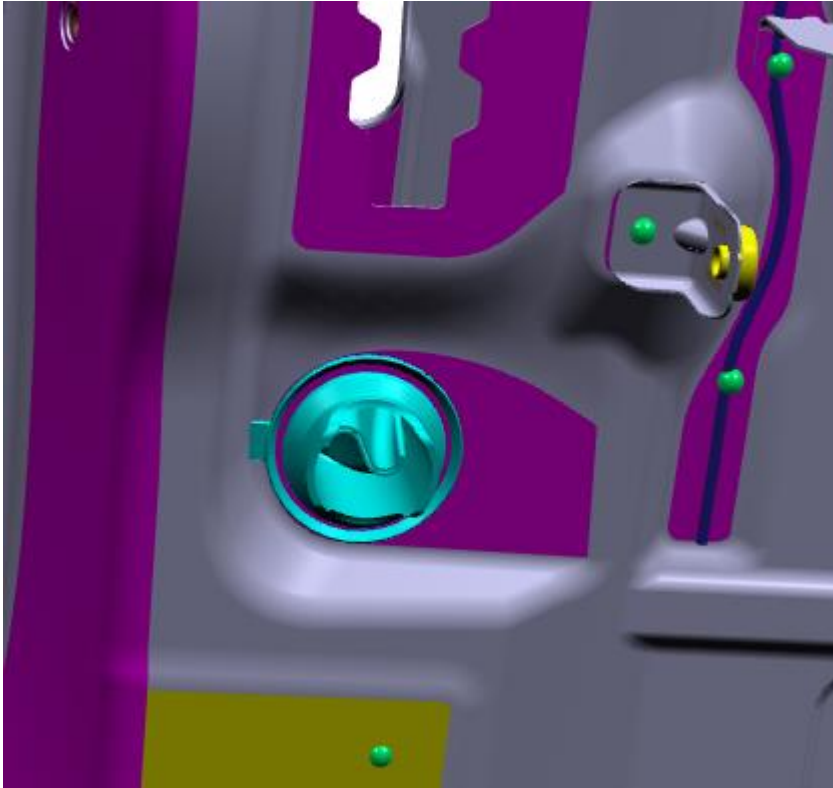

Situation: There is a water leak near the trunk area or you have a water leak near the front carpets. The drain tubes may not be properly connected at the A-Pillar or D pillar at the bottom

Repair: Make sure that drain grommet is seated correctly in the A-Pillar. If not, correctly seat grommet.



DRAIN TUBES CLOGGED (DIRT/DEBRIS)

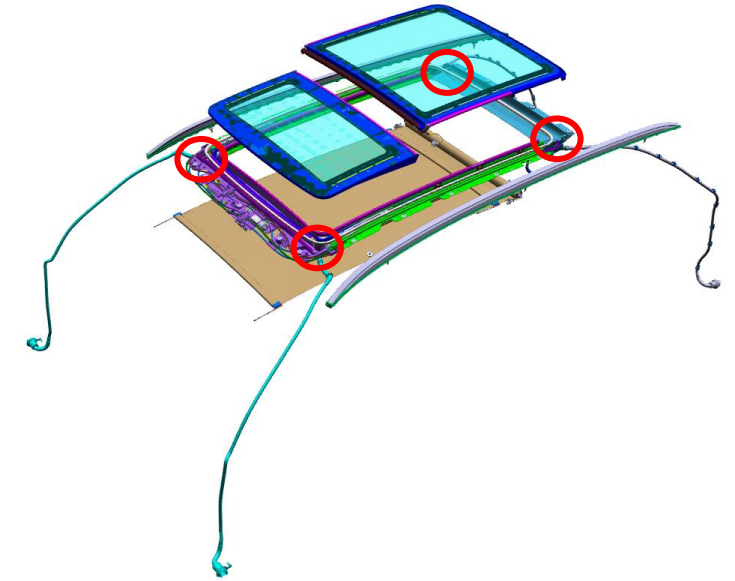
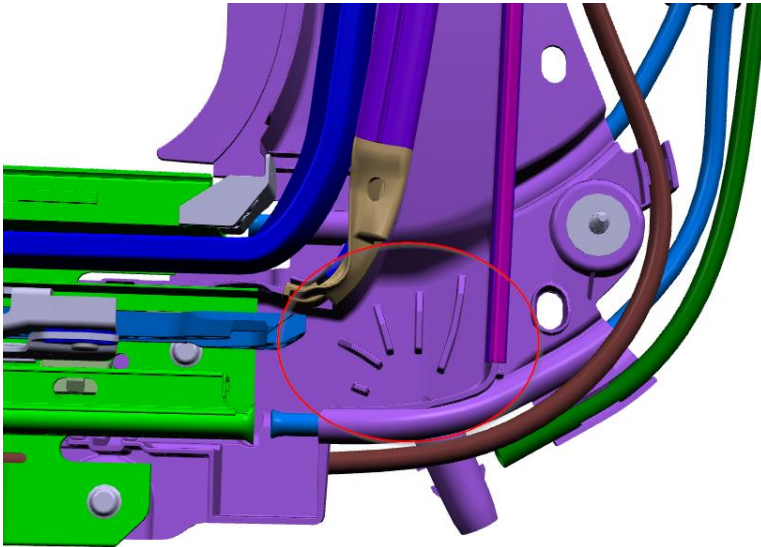

Situation: There is a water leak onto the carpets. The drain tubes may be clogged.

Repair: Verify water flow through drain tube. Check for twist/kinks in drain hoses first. If no defect is found, gently blow air through drain tube to force debris to come out. Submit TSARA case for assistance if clog cannot be cleared.



AERO ACOUSTIC SEAL NOT INSTALLED / STUCK

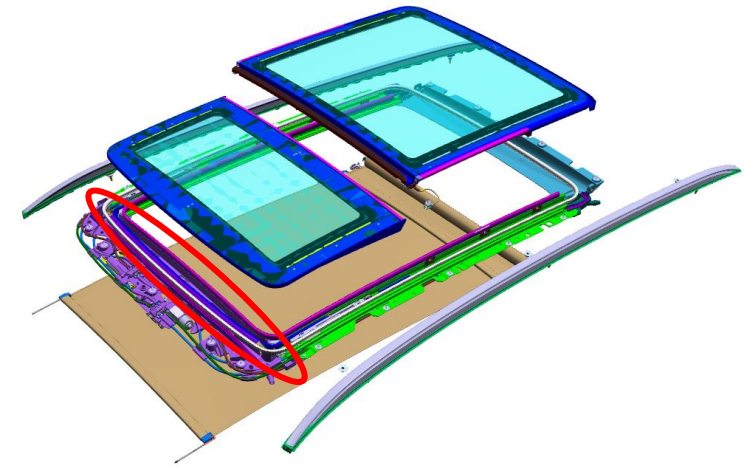
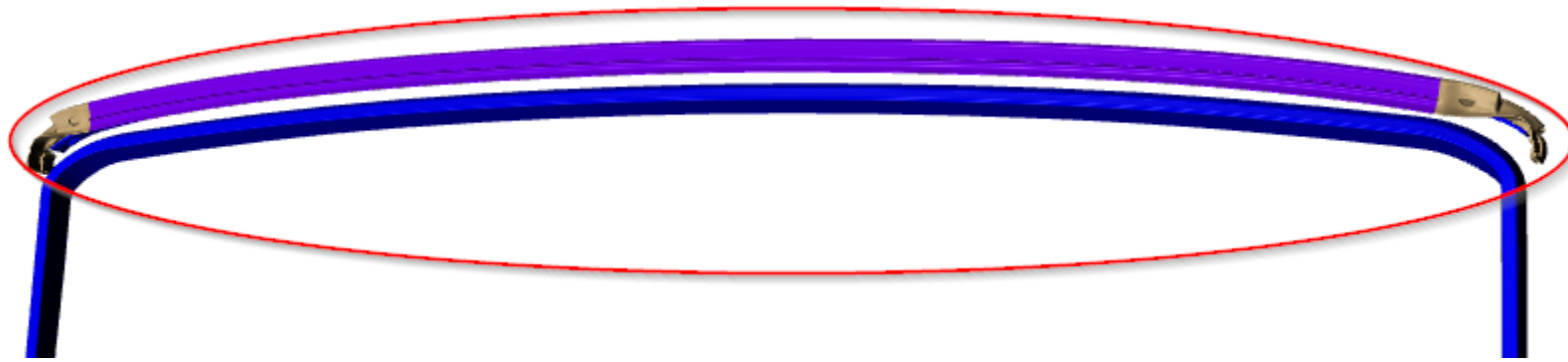

Situation: There is a water leak in the front. The aero-acoustic seal may be incorrectly installed or deformed.

Repair: Check if seal is properly seated and in good condition. If not, then reseal or replace the aero-acoustic seal and replace the body seal according to ISTA/AIR instructions REP 54 13 055.



AERO ACOUSTIC SEAL VENT/ DRAIN HOLES BLOCKED/ FLASH

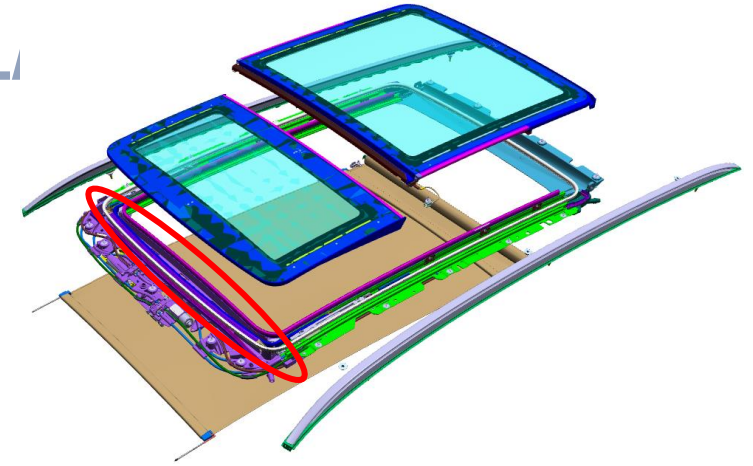

Solution: There is a water leak in the front. The aero-acoustic seal may have flash or blockage at the front vent/ drain holes.

Repair: Check if the seal is blocked at the front corners. If the holes are block by flash then replace the aero-acoustic seal.



REAR BEAM DYKO SEAL NOT INSTALLED

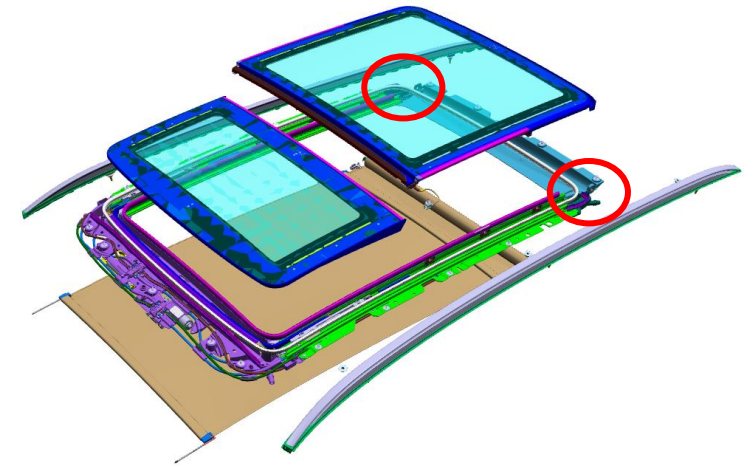
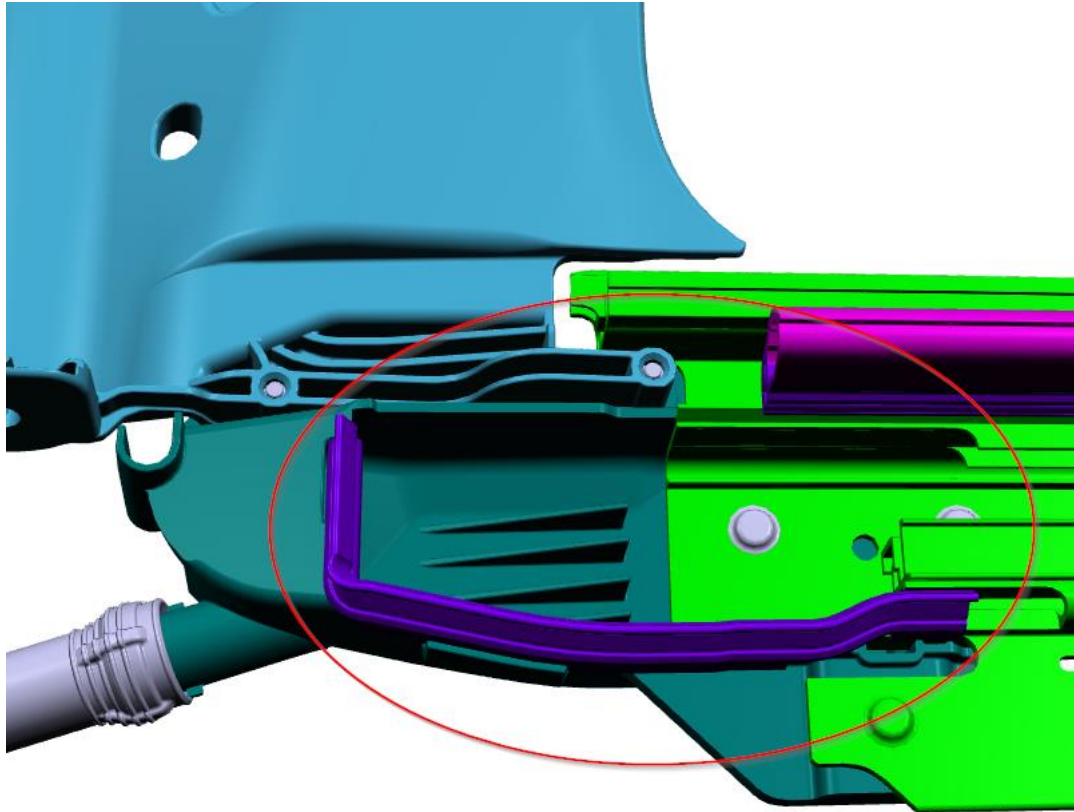

Situation: There is water ingress in the trunk area. The rear beam seal may not be installed.

Repair: Check if seal is properly seated. Loosen bolts to lower the frame in order to properly inspect seal. If seal is completely missing then replace frame according to ISTA/AIR instructions REP 54 13 261.



WIND NOISE



WHERE IS THE WIND NOISE COMING FROM?

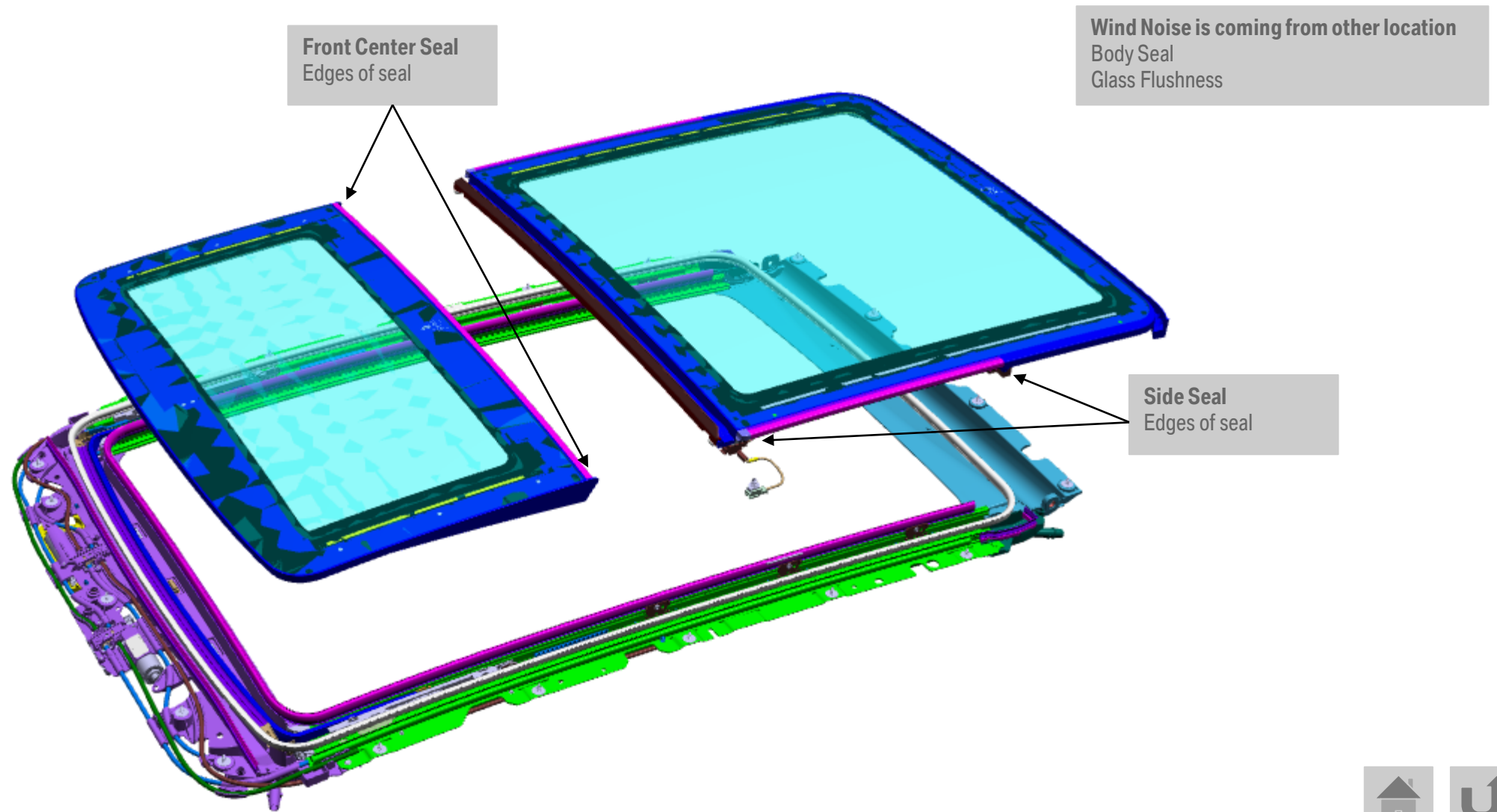

FRONT CENTER SEAL LOOSE/SHRINKING

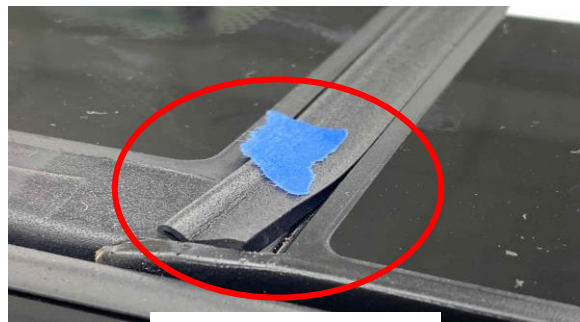
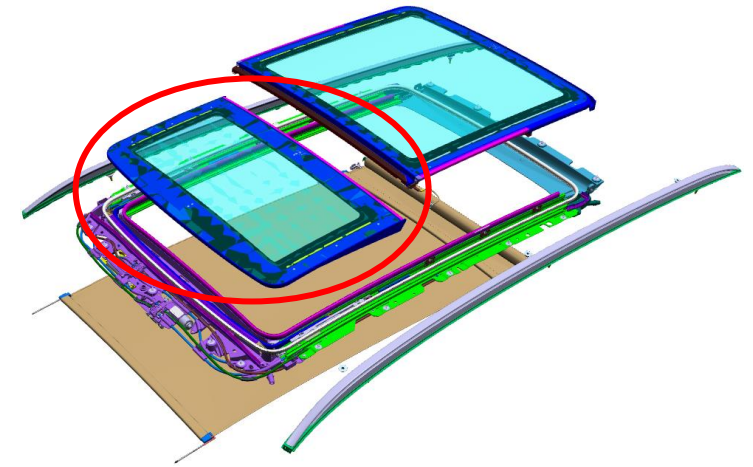
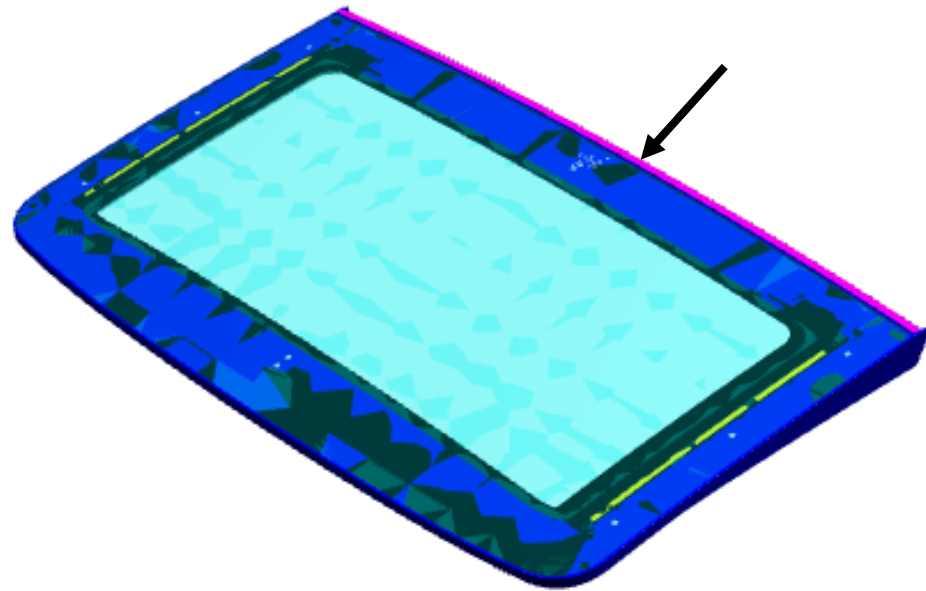

Defect: separated



Defect: shrunken / gap

Situation: Wind noise heard at speeds of 30 Mph. A gap can be seen near the end of the seal on front glass.

Repair: Replace seal according to ISTA/AIR instructions REP 54 13 052. Refer to B54 04 21.



SIDE SEAL LOOSE/SHRINKING

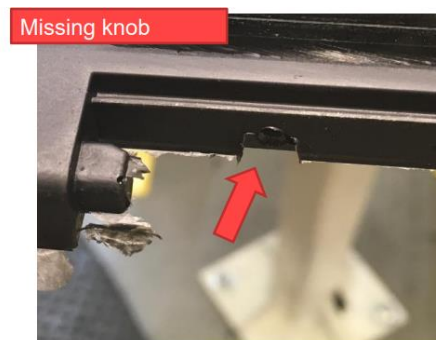
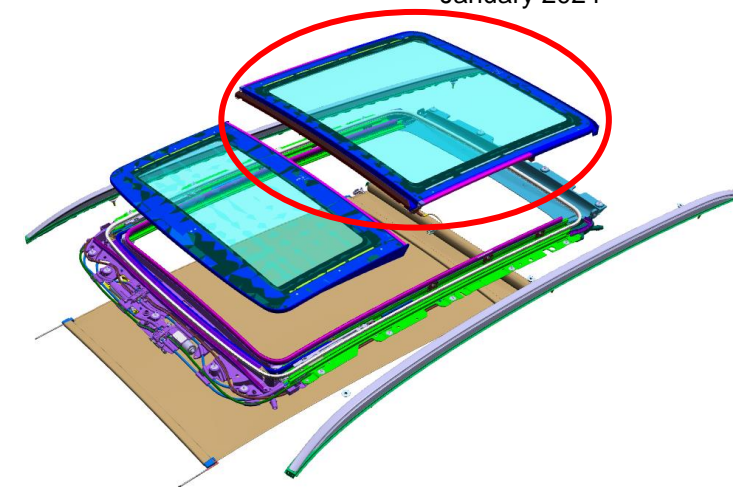
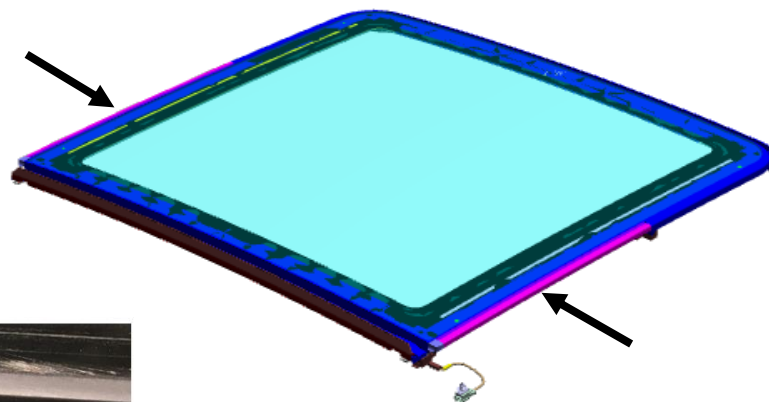

example: gap



example: twist



example: loose

Situation: Wind noise heard at speeds of 30mph.

Repair: Look for gap near ends or twist in seal. If found, replace seal according to ISTA/AIR instructions. REP 54 13 050. If the knob or locking feature is missing on the rear glass panel replace the rear glass panel.

BODY SEAL NOT ATTACHED

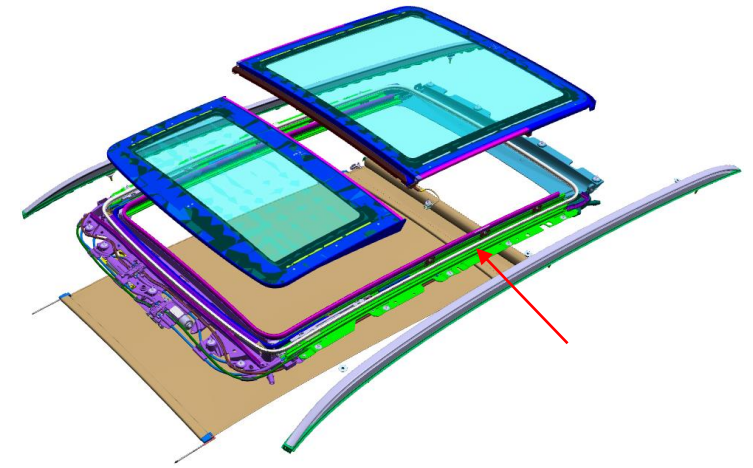
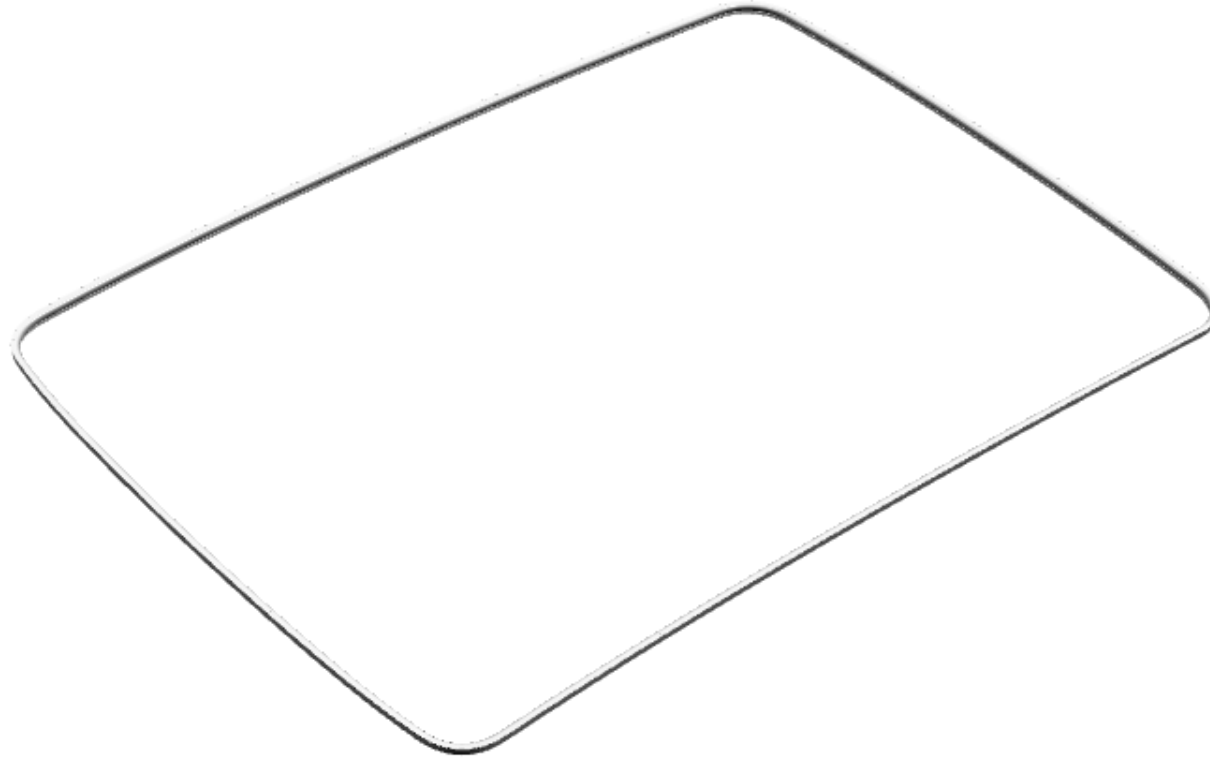

Situation: The body seal may be detached or improperly installed.

Repair: Check body seal to see if it is flush to vehicle.
(no loose areas/wrinkles)

If damaged, replace body seal according to ISTA/AIR instructions REP 54 13 055.

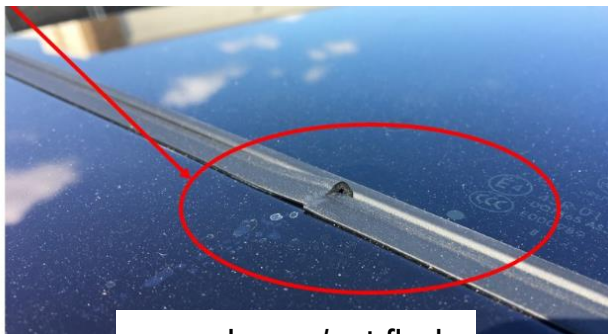

example: gap/not flush



example: gap/not flush

GLASS NOT FLUSH

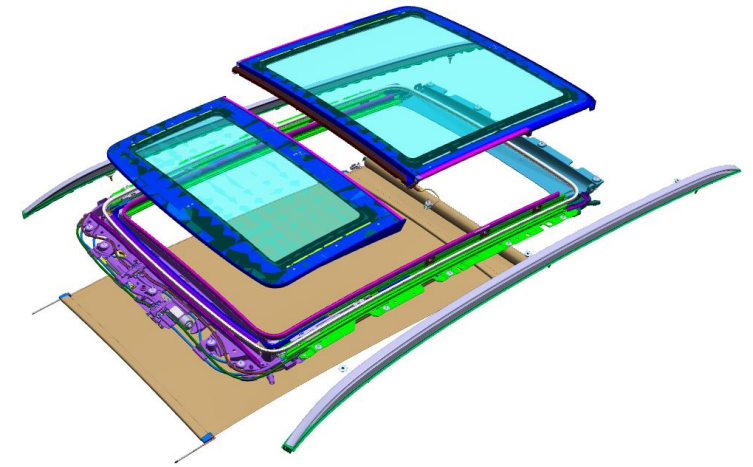
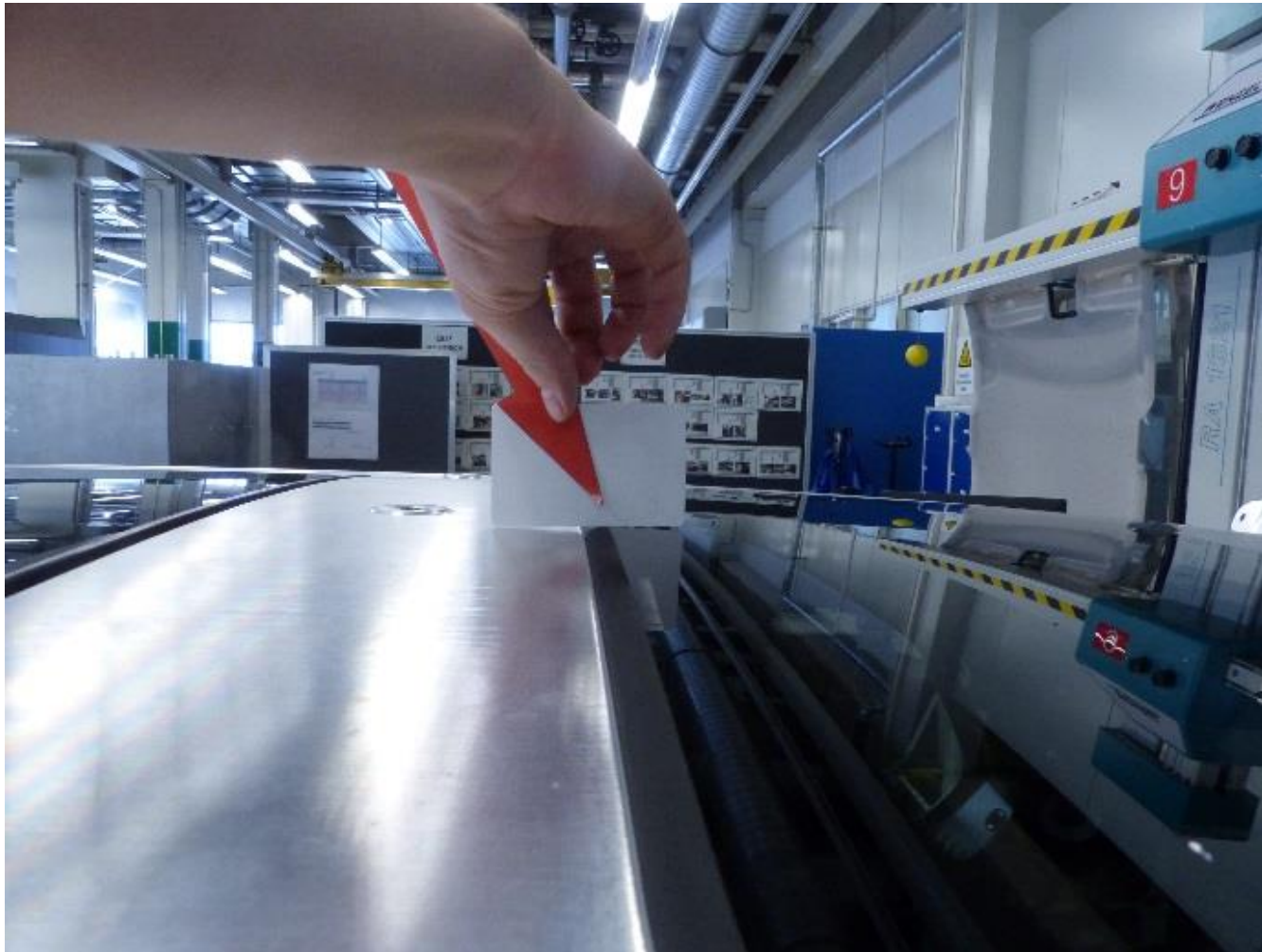

Situation: Rushing wind noise is heard from center of the glass.

Repair: Tape can be used to isolate noise and find where glass is not flush.

Adjust both sunroof glass panels according to ISTA/AIR instructions REP 54 13 002.



STATIC NOISE

WHAT DOES THE STATIC NOISE SOUND LIKE?

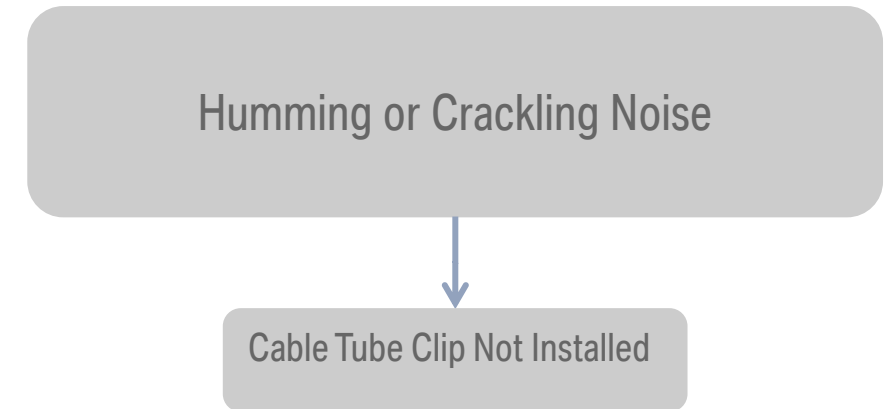
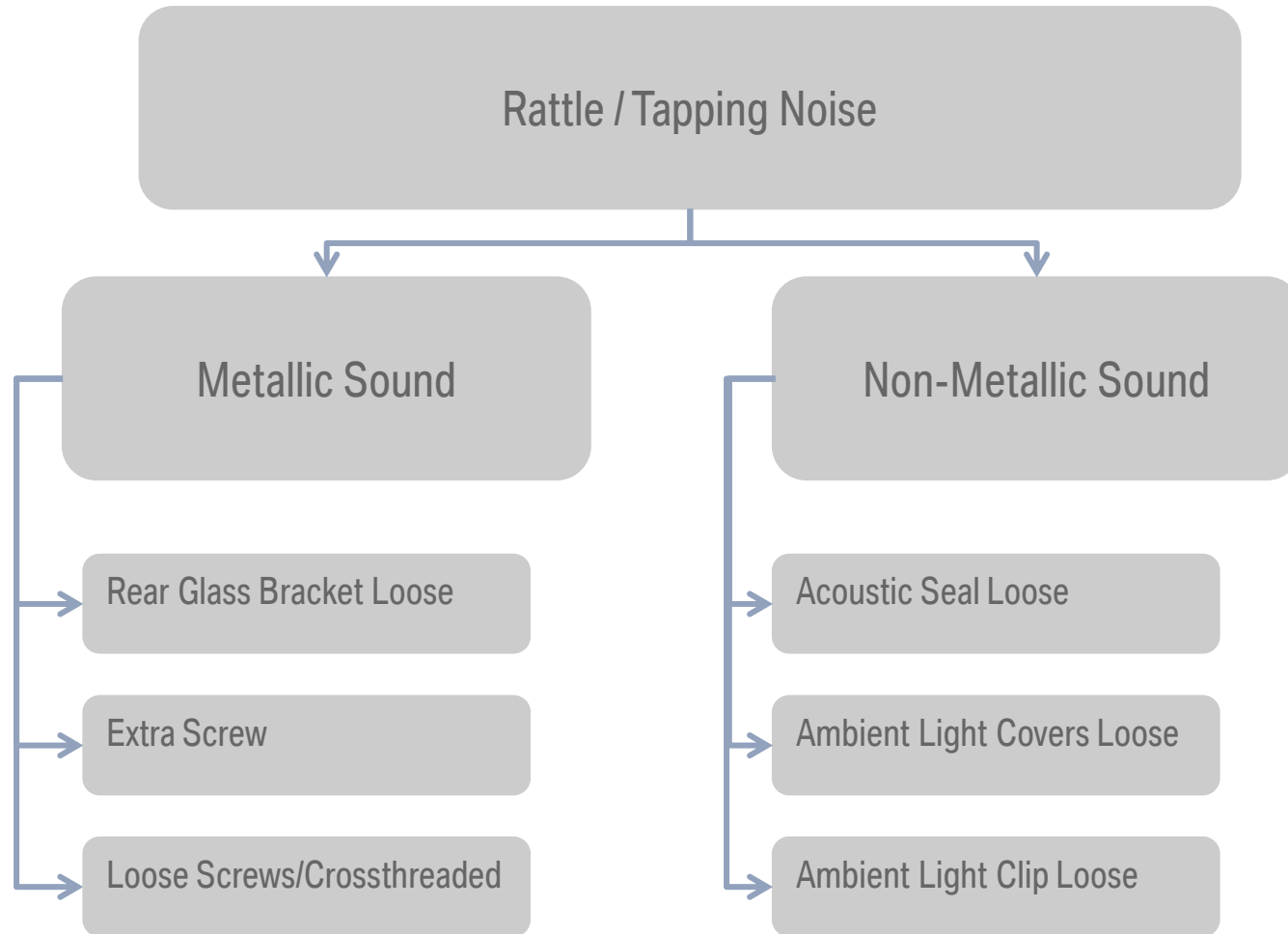

ACOUSTIC SEAL LOOSE

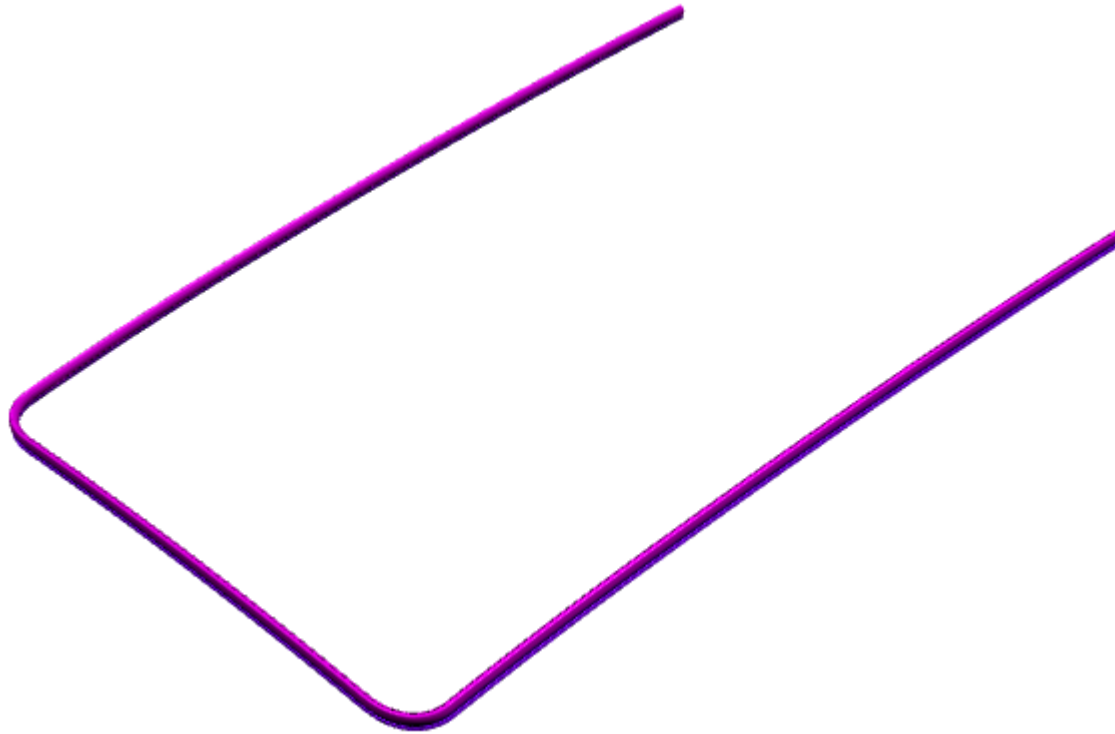

This seal will not cause a water leak into the vehicle and should not be replaced to solve a water leak on the panoramic roof.

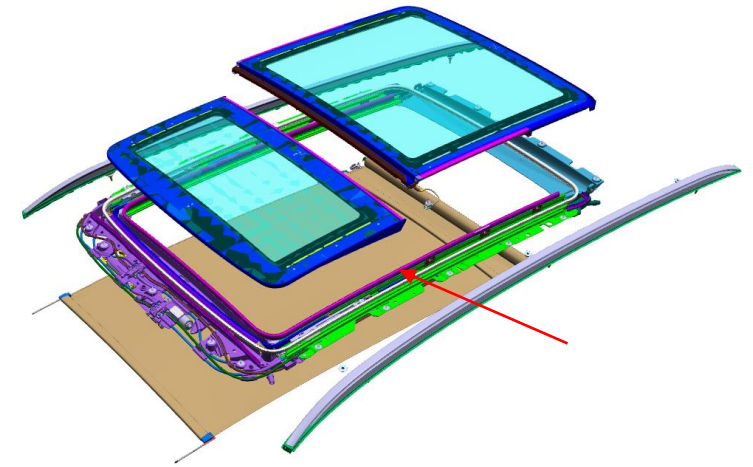

Situation: Rattle or groaning noise heard while driving over rough road surfaces. Upwards pressure on the glass will stop the noise. The cause is interference between the sunroof glass and acoustic seal mounted to the sunroof frame (not the roof perimeter seal).

Repair: Slightly lower glass (within specification) to increase pressure between the glass and the seal.



REAR GLASS BRACKET LOOSE

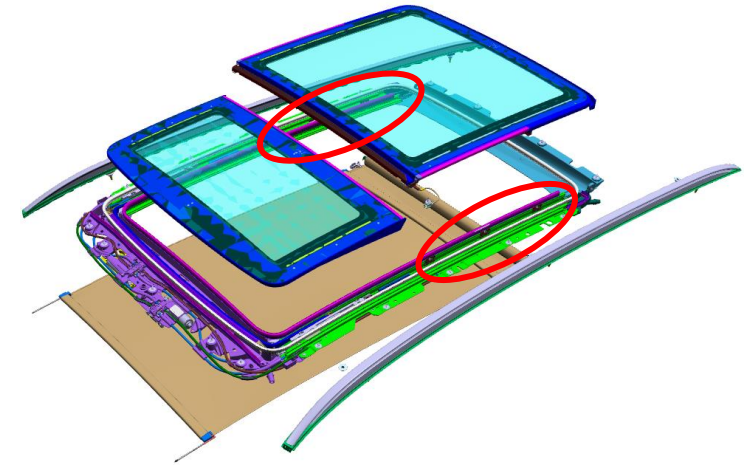
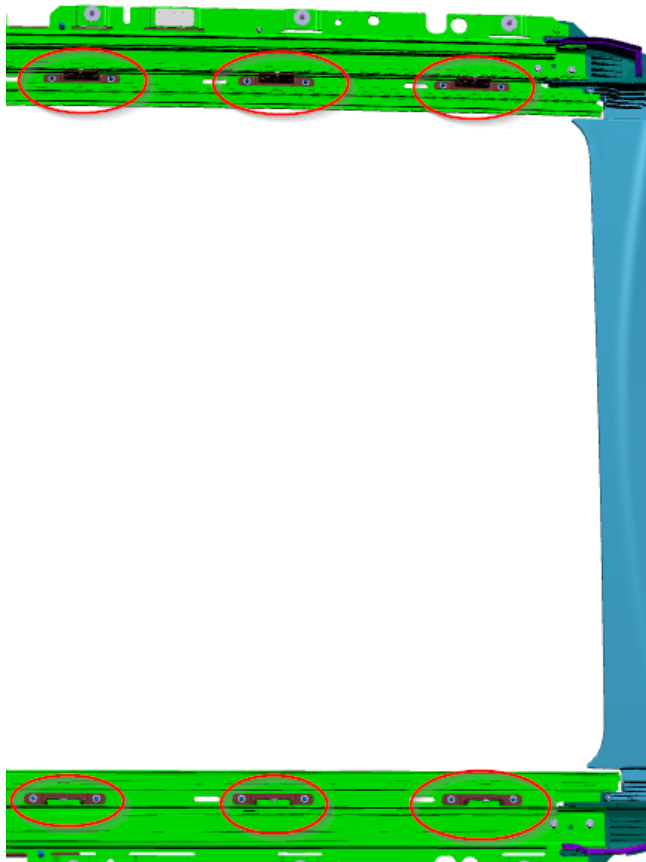

example

Situation: Metallic noise heard while driving over rough road surfaces.

Repair: Inspect bracket screws (**Bracket to frame**, not glass to bracket). Check for any cross threaded screws. If cross threaded screws are found then replace screws. Tighten loose screw(s) to 6.1Nm to fully seat. If the screws can't be tightened correctly, the frame would need replacement.



AMBIENT LIGHT COVERS LOOSE

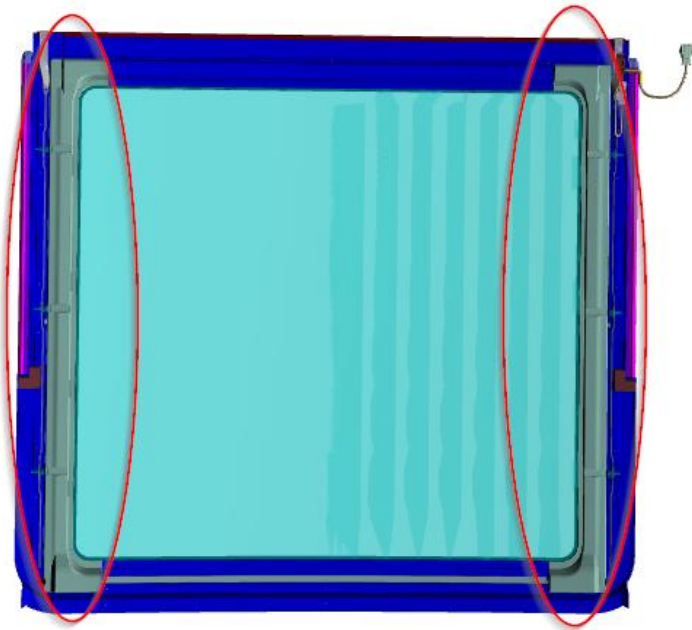
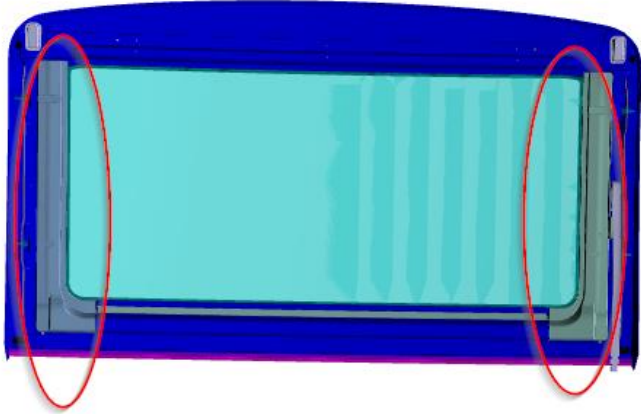

example

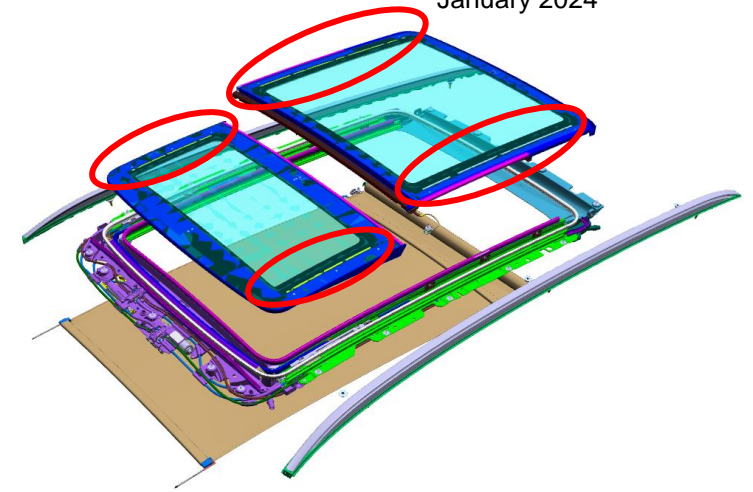

Situation: Rattle is heard from plastic cover tapping on glass panel (front or rear glass) when driving on rough road surfaces.

This situation only affects vehicles with SA407 (Panoramic Sky Lounge LED Roof)

Repair: Attempt to insulate with felt tape is visually appropriate. Replace glass panel according to ISTA/AIR instructions REP 54 13 250 if insulation is not possible.



AMBIENT LIGHT CLIP LOOSE/NOT INSTALLED

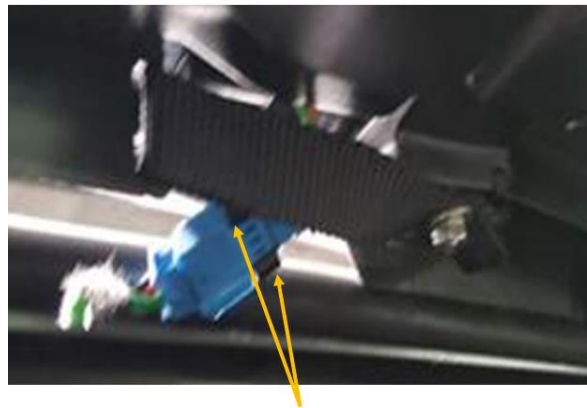
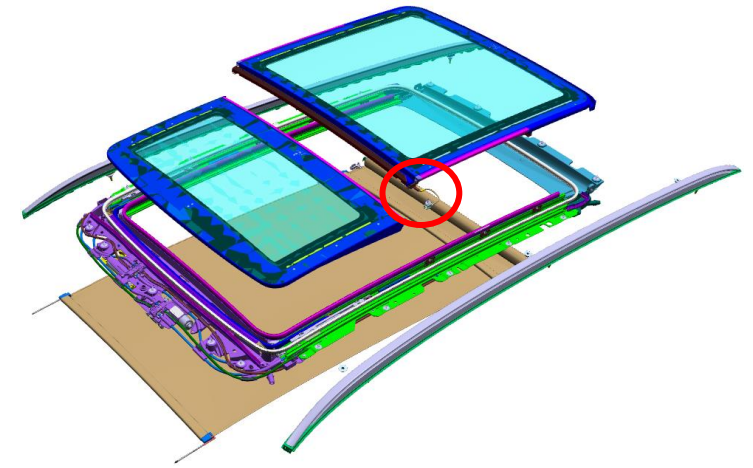
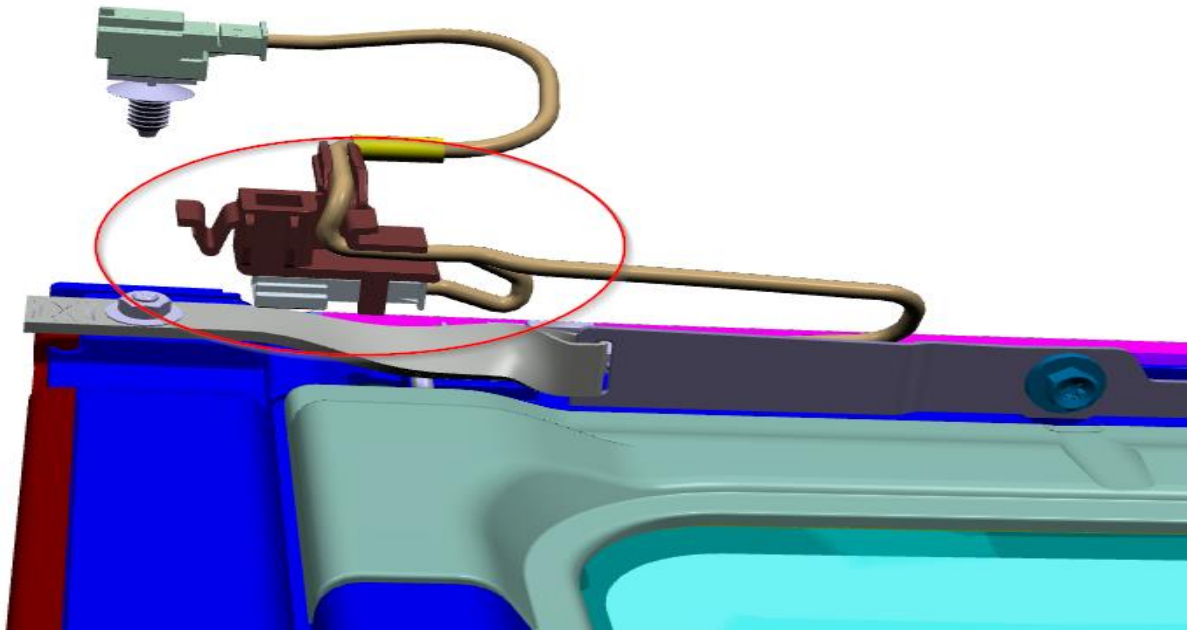

Clip loose with prongs attached to connector



Clip attached to panel with a press fit rib on the back into a slot on the panel. Glass supplier glues the rib with cyanoacrylate glue.

Situation: A loose clip for the ambient light harness is tapping on the glass or contacting the sunroof mechanism. Only affects vehicle with SA407 (Panoramic Sky Lounge LED Roof).

Repair: Correctly install the harness clip.



CABLE TUBE CLIP NOT INSTALLED

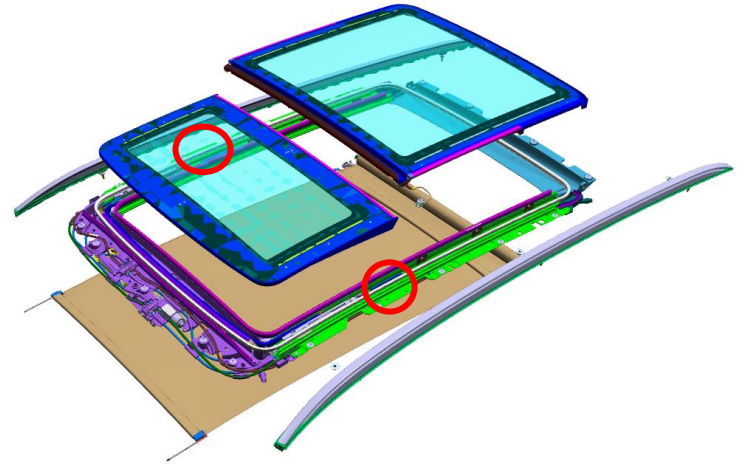
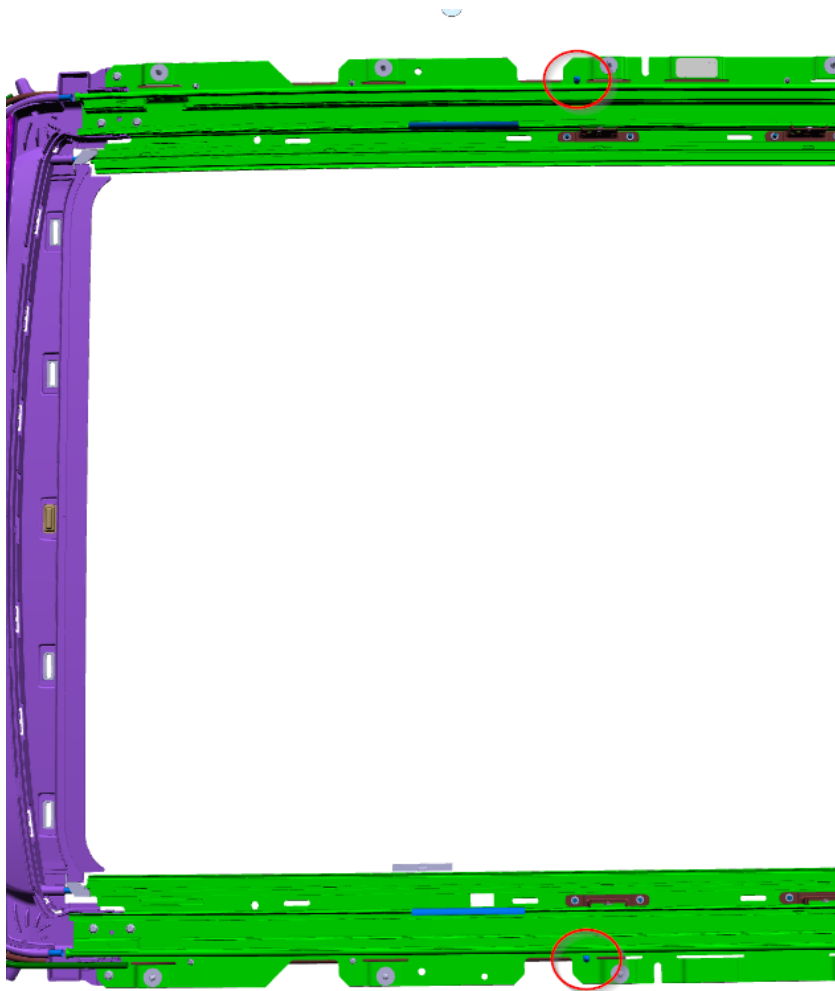

Situation: There is humming / crackling sound when opening the sunshade or plastic rattling while driving on rough roads.

Repair: Engage/set clip correctly. If tube is damaged and noise persists then replace cassette according to repair instructions.

EXTRA SCREW

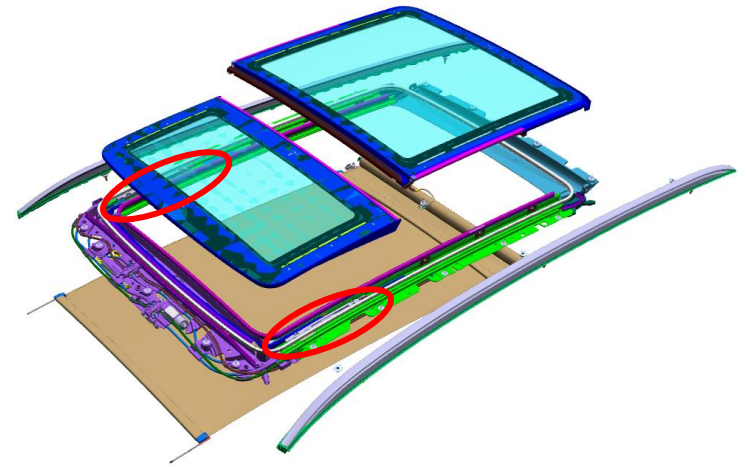
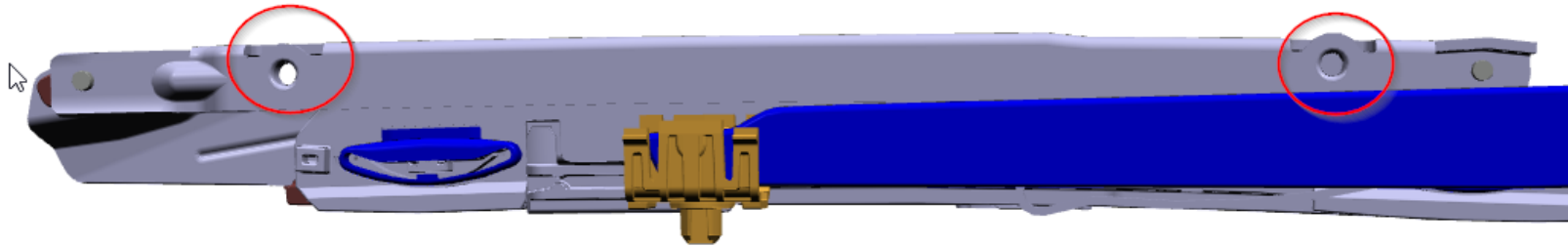

Situation: A metallic “rolling” noise is heard during acceleration/deceleration. An extra screw may have fallen into the track during production. The screw is not missing from any location.

Repair: Remove the extra screw. Additional repairs are not necessary, all other screws are correctly installed.



LOOSE FRAME TO BODY SCREW/ FRAME TO GLASS SCREW

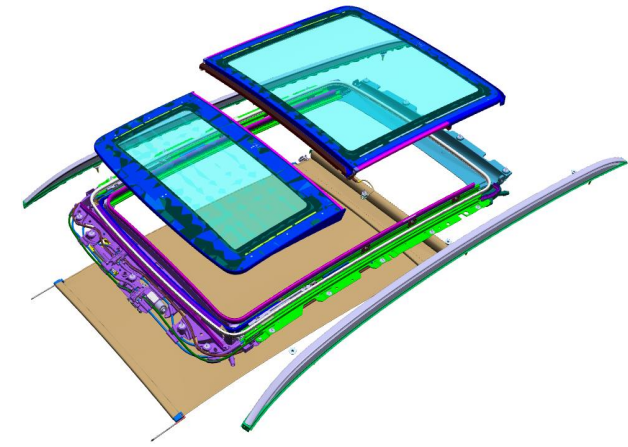
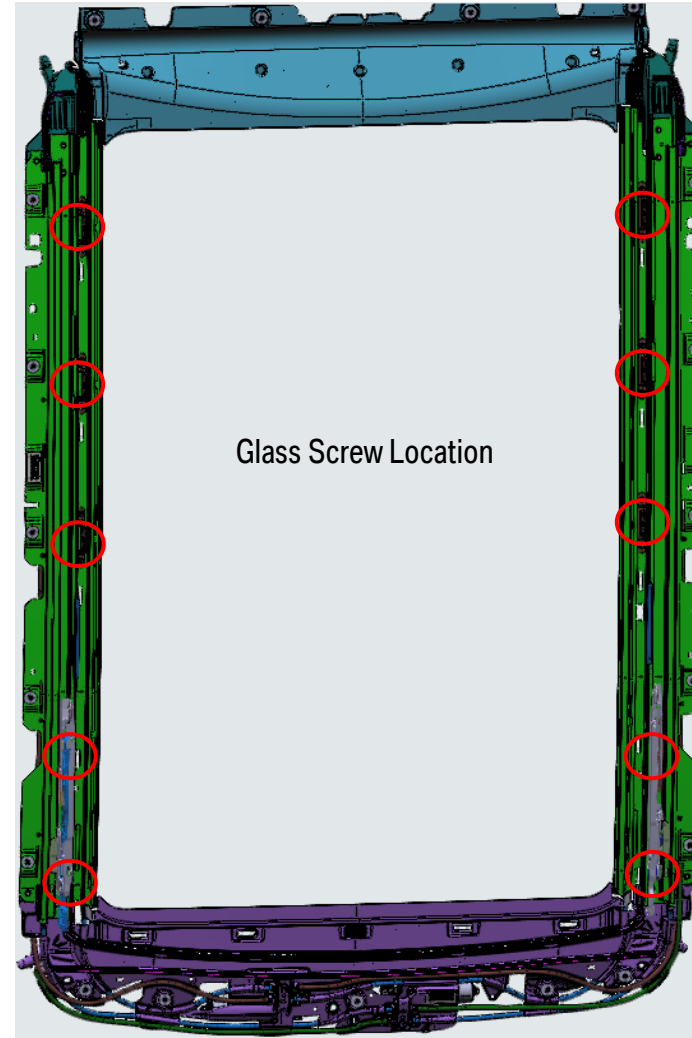
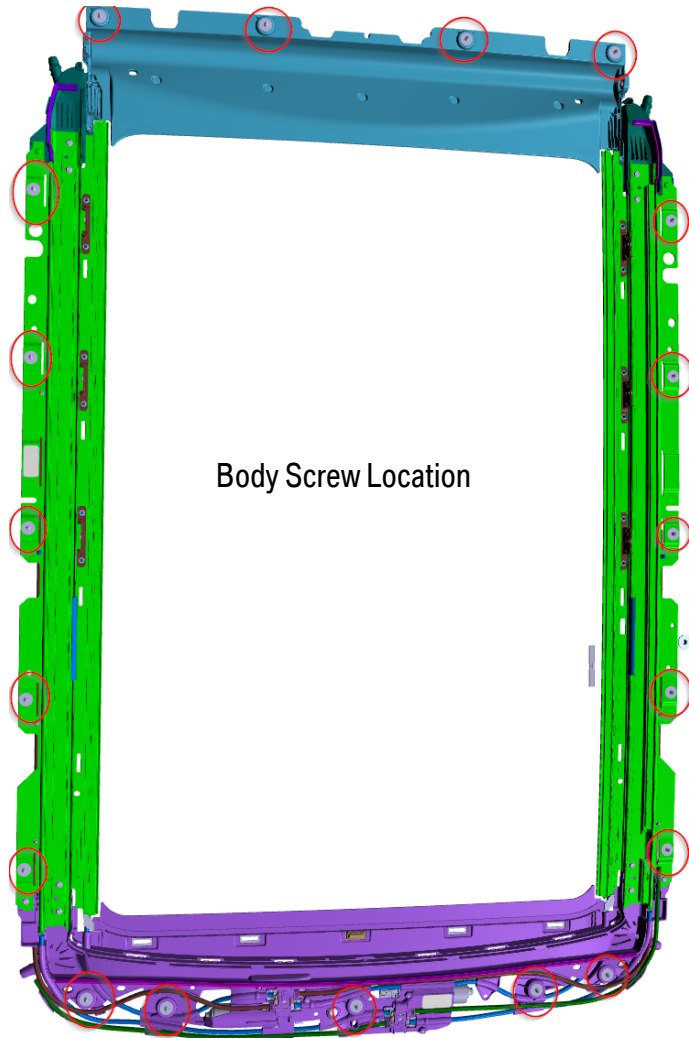

Situation: Rattling noise is heard from the roof area. One or more sunroof frame screws may be loose.

Repair: Inspect screws for signs of cross-threading. Replace screws if damaged. Retorque frame screws correctly according to ISTA/AIR repair instructions to 5.4nm. Retorque glass panel screws to 4.5nm. Note: Ensure headliner clips are engaged and not broken.



FUNCTION NOISE

WHAT DOES THE FUNCTION NOISE SOUND LIKE?

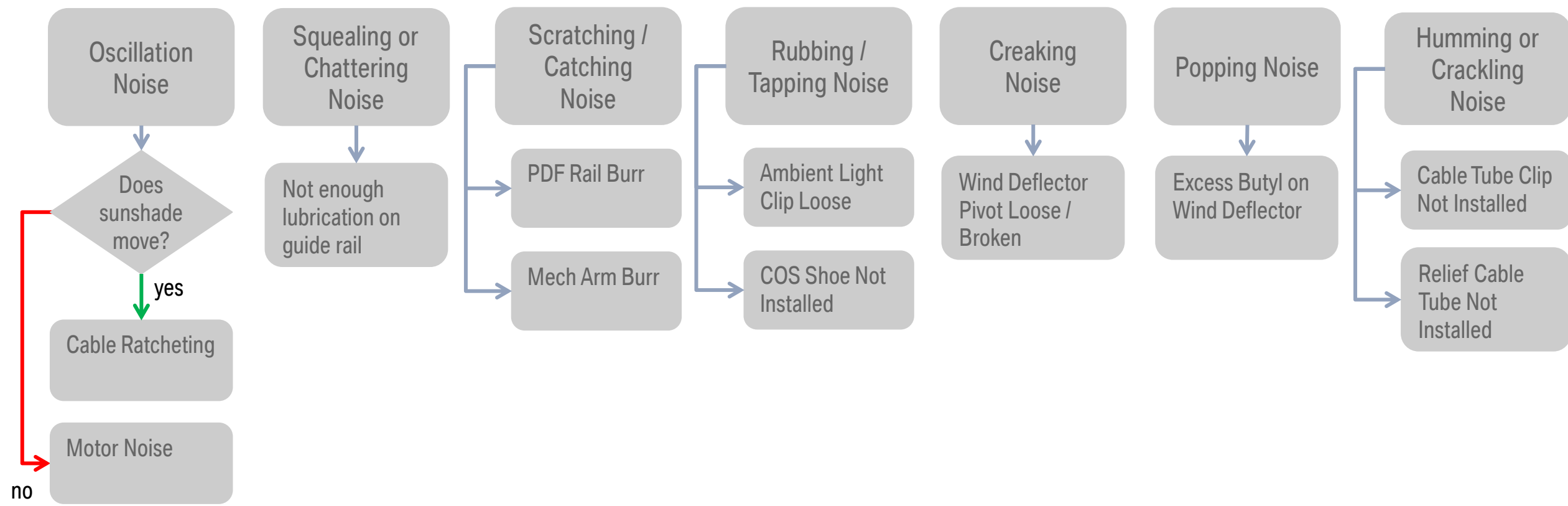

MOTOR NOISE

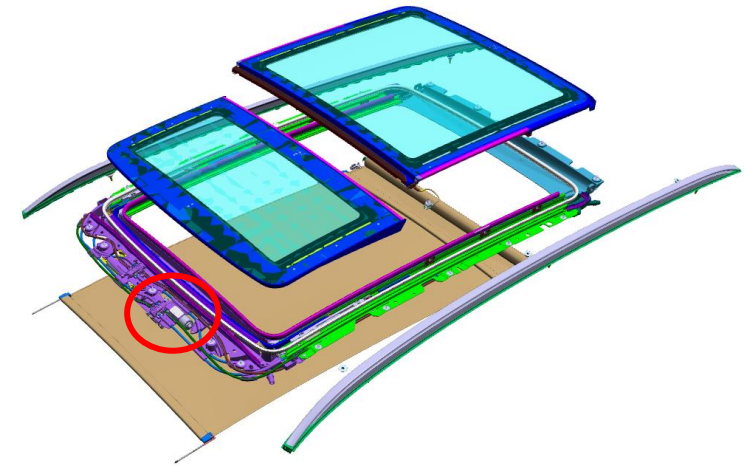
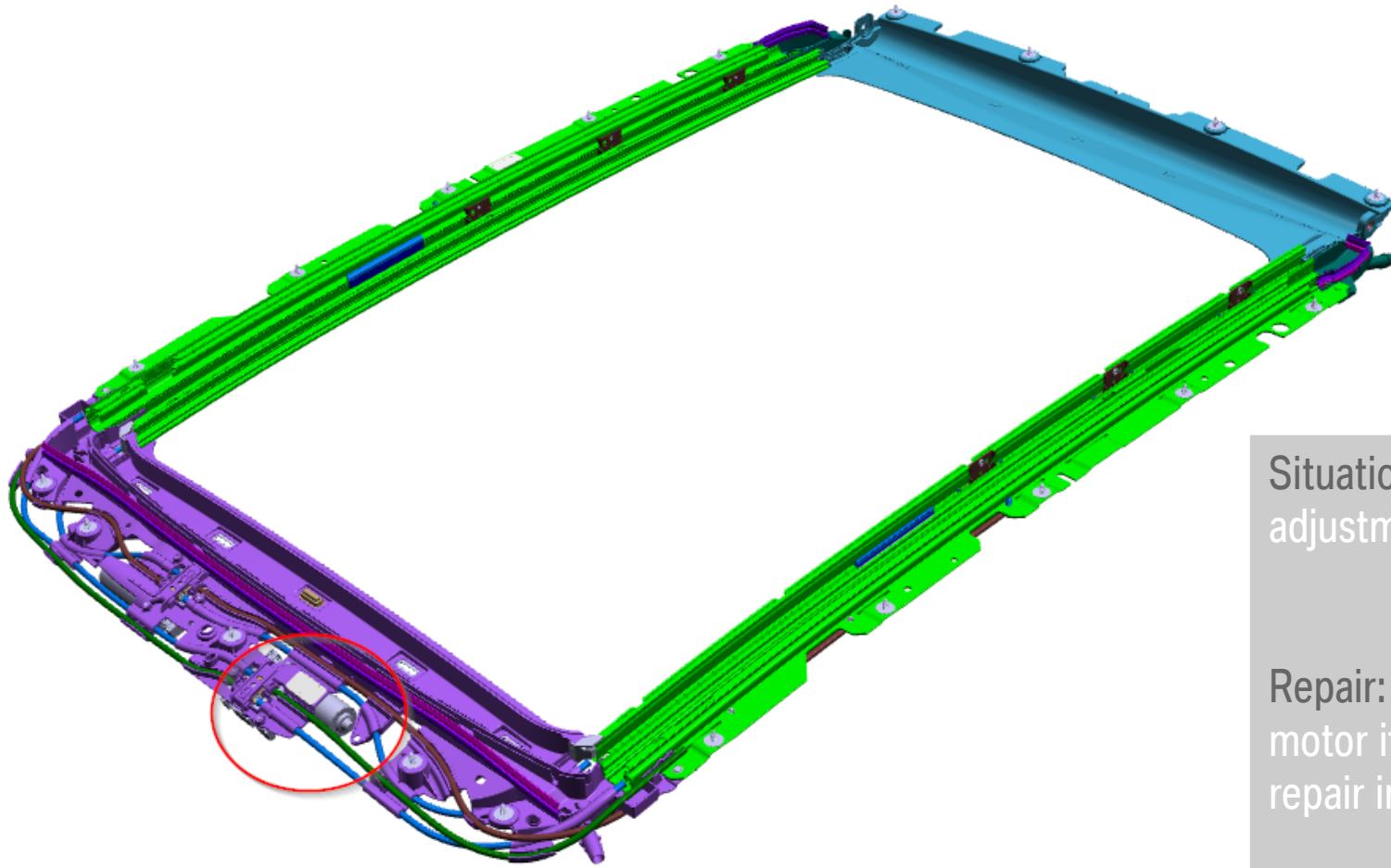

Situation: An oscillation noise is present from the adjustment motor when the shade or glass is moving.

Repair: Swap/replace the motor and retest. Replace the motor if found to be the cause according to ISTA/AIR repair instruction REP 67 61 580.



CABLE RATCHETING

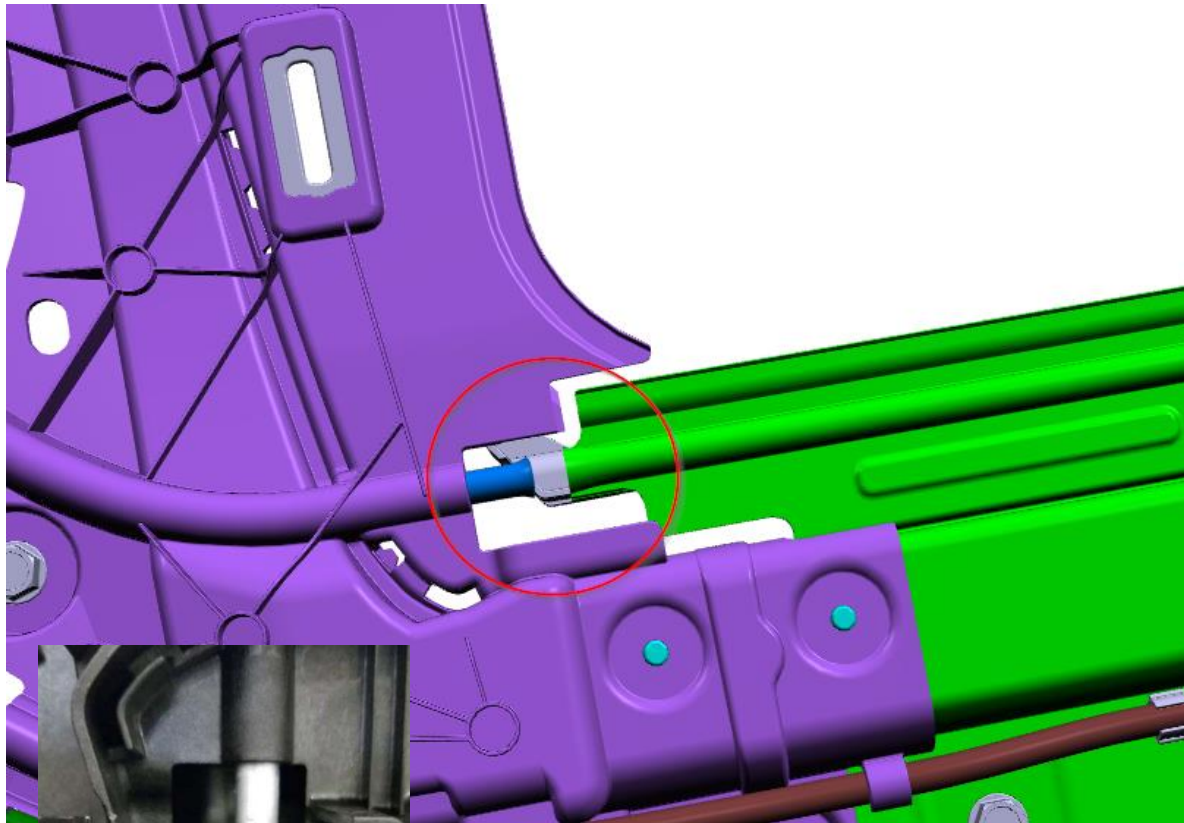

Defect: misaligned or burr

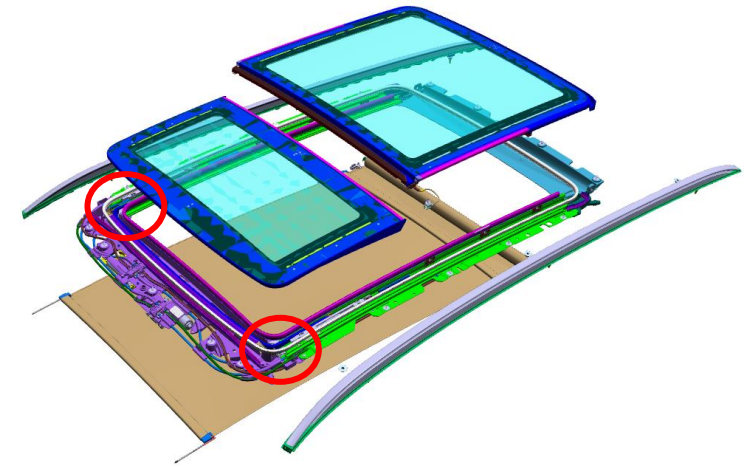

Situation: A quiet oscillating/chattering noise is present when moving only the sunshade.

Repair: Inspect the sunroof frame for misalignment or a burr on the cable guide as shown. If damage is found, replace the frame according to ISTA/AIR instructions REP 54 13 261.



GUIDE RAIL NOT ENOUGH LUBRICATION

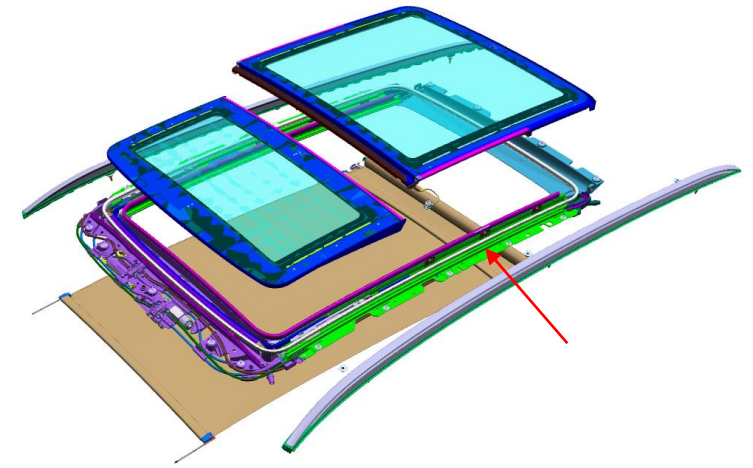
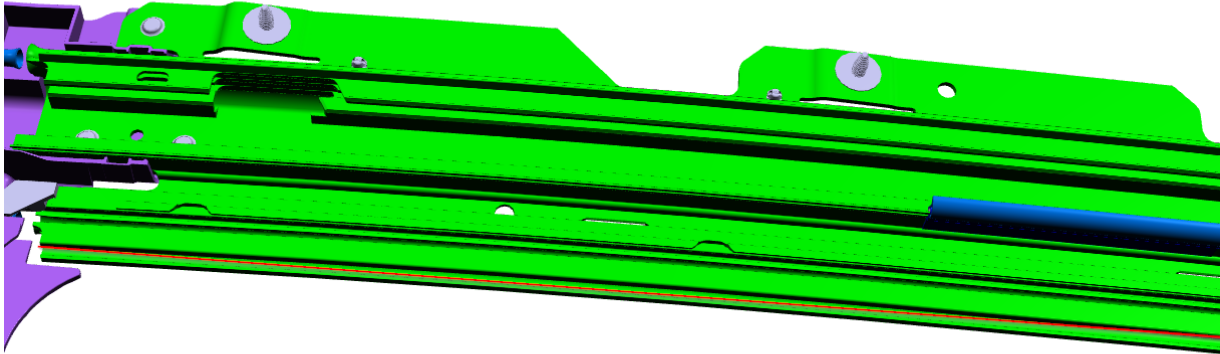

Situation: A squealing or chattering noise is heard when moving the sunshade. Typically on Alcantara (suede) equipped vehicles.

Repair: Clean and lubricate the sunroof guides. If noise persists then replace sunshade according to ISTA/AIR instructions REP 54 13 548.



PDF RAIL BURR

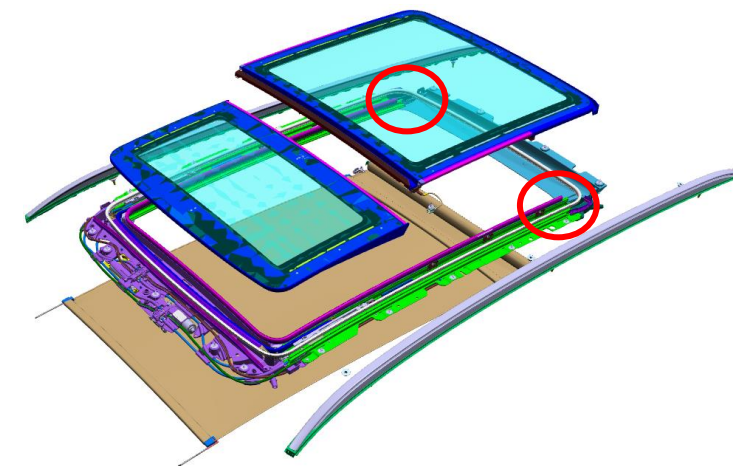
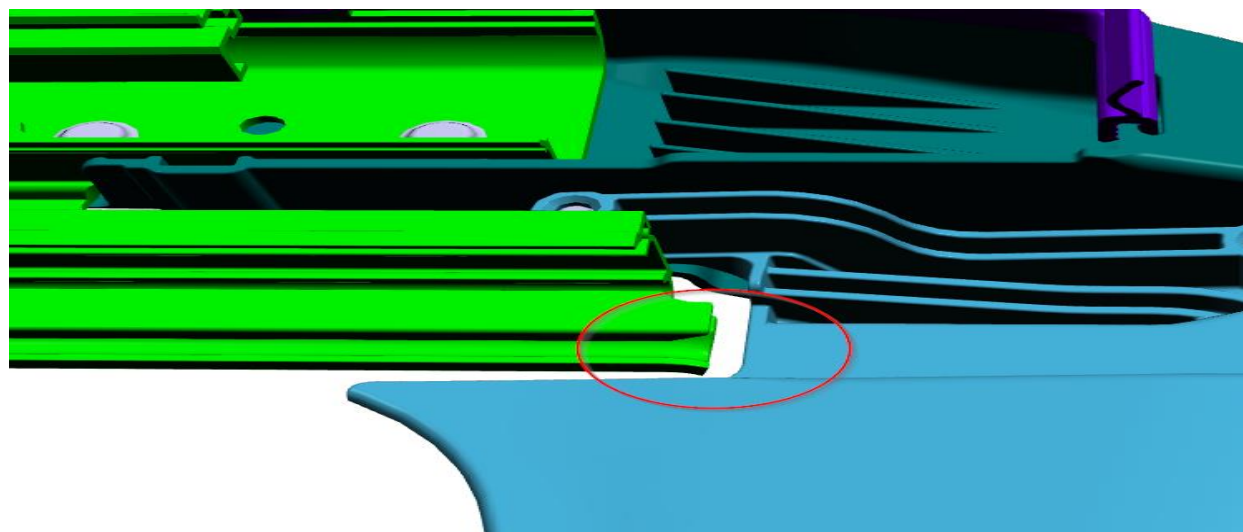

Sharp/Burr on Rollo entry at rear of guide

Burr on PDF lip on guide



Run a round pick across these two edges to break the edge.



Knock off any vertical burr on horizontal surface and touch up with a black paint pen or permanent marker.

Situation: A scratching/catching noise is heard while shade is moving.

Repair: Remove the burr on the edge of the PDF rail to break the edges. If the noise is still present then replace cassette frame according to ISTA/AIR instructions REP 54 13 261.

GUIDE SHOE NOT INSTALLED CORRECTLY

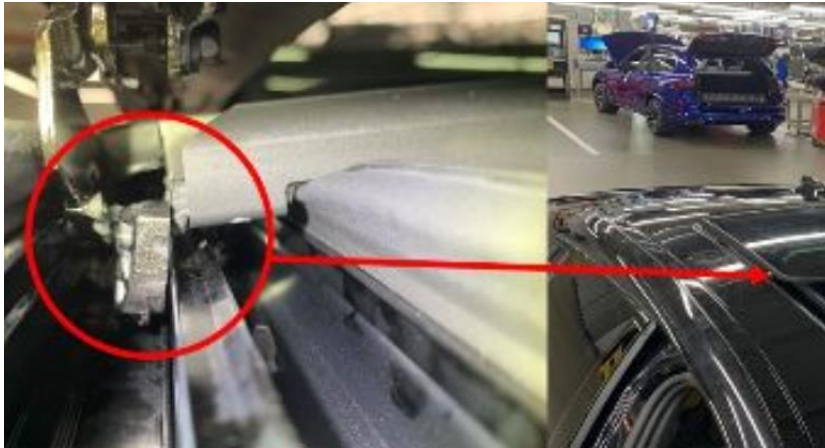
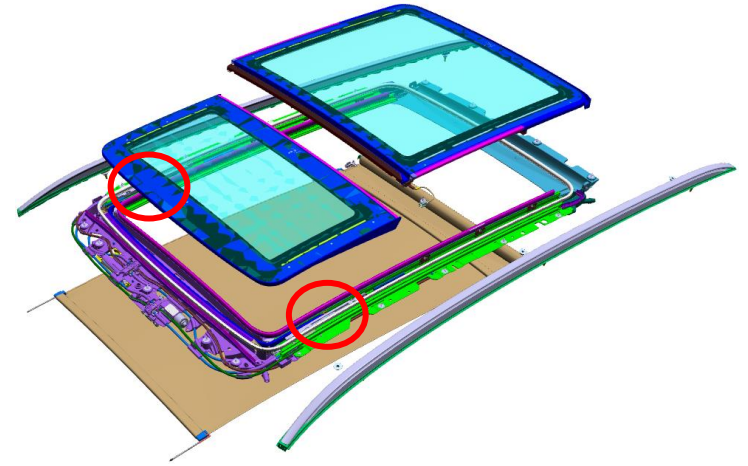
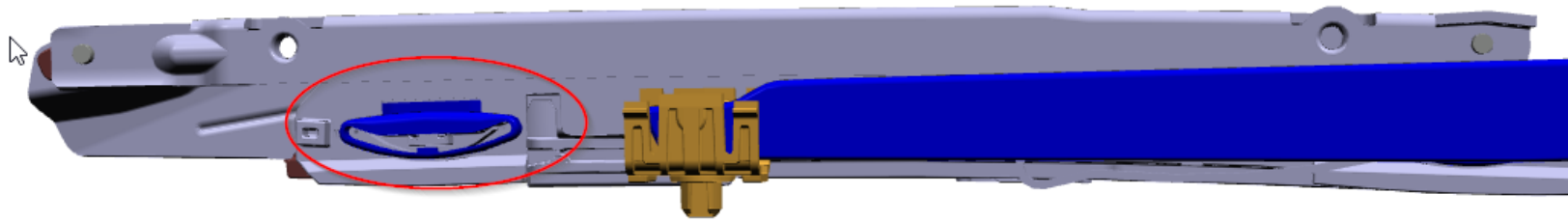

Situation: A rubbing/tapping noise heard when glass is moved.

Repair: Replace mechanism according to ISTA/AIR instructions REP 54 13 515.

AMBIENT LIGHT CLIP LOOSE/NOT INSTALLED

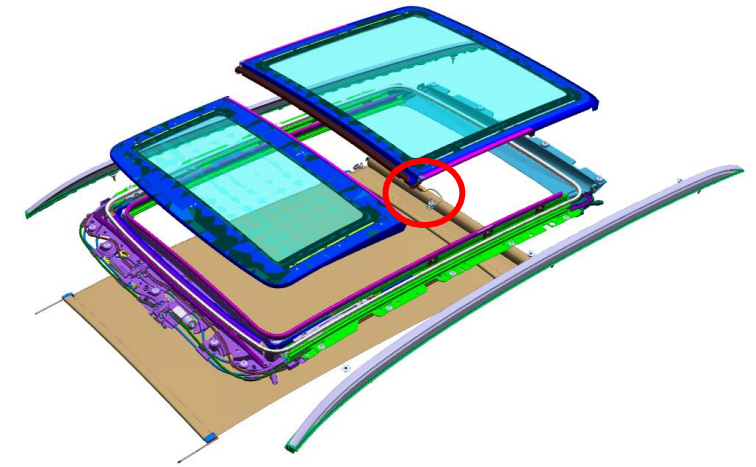
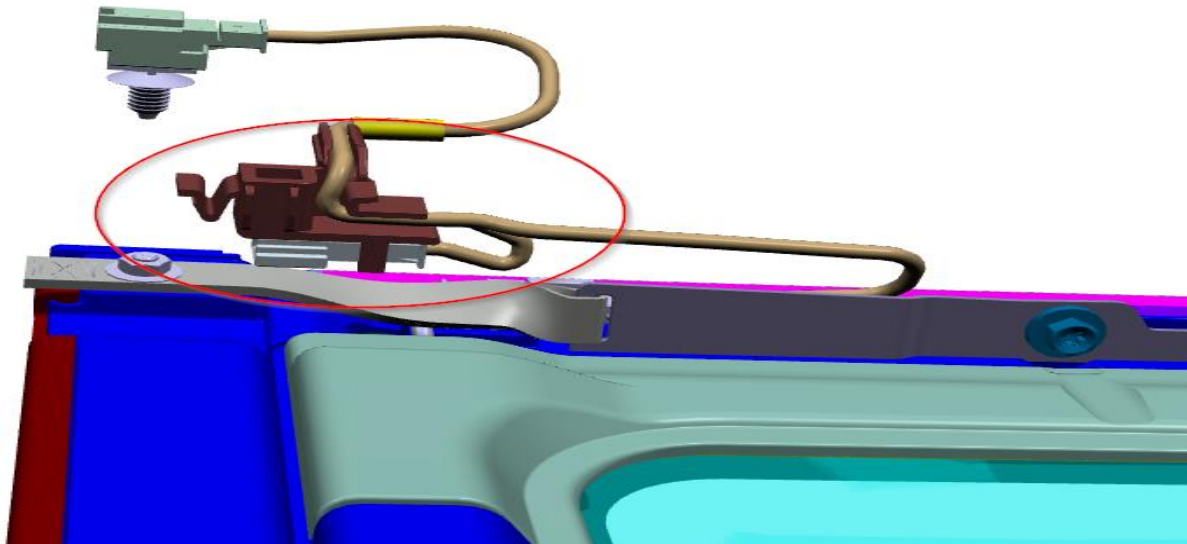

Situation: A loose clip for the ambient light harness is tapping on the glass or contacting the sunroof mechanism. Only affects vehicle with SA407 (Panoramic Sky Lounge LED Roof).

Repair: Correctly install the harness clip.

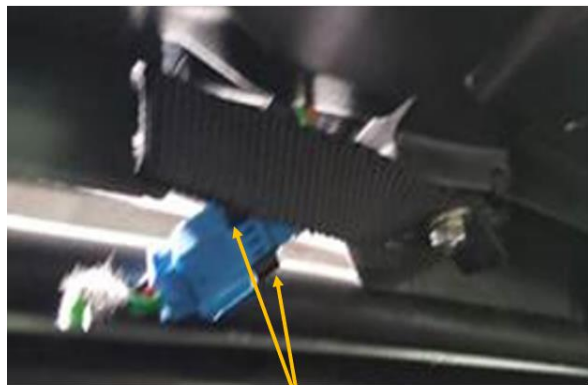

Clip loose with prongs attached to connector



Clip attached to panel with a press fit rib on the back into a slot on the panel. Glass supplier glues the rib with cyanoacrylate glue.

WIND DEFLECTOR PIVOT POINT LOOSE/BROKEN

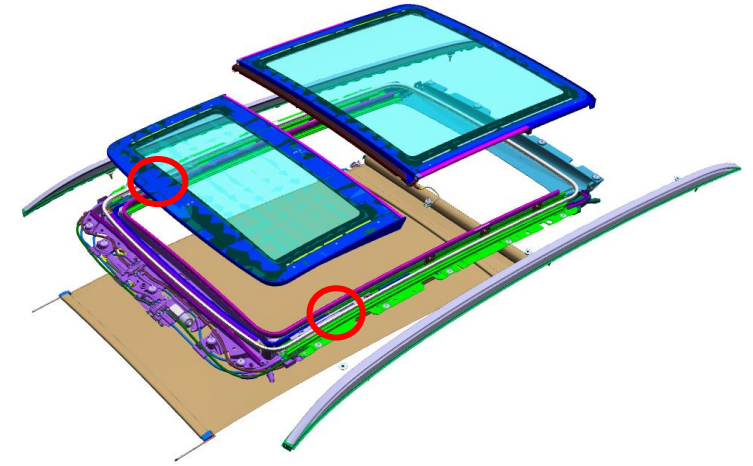
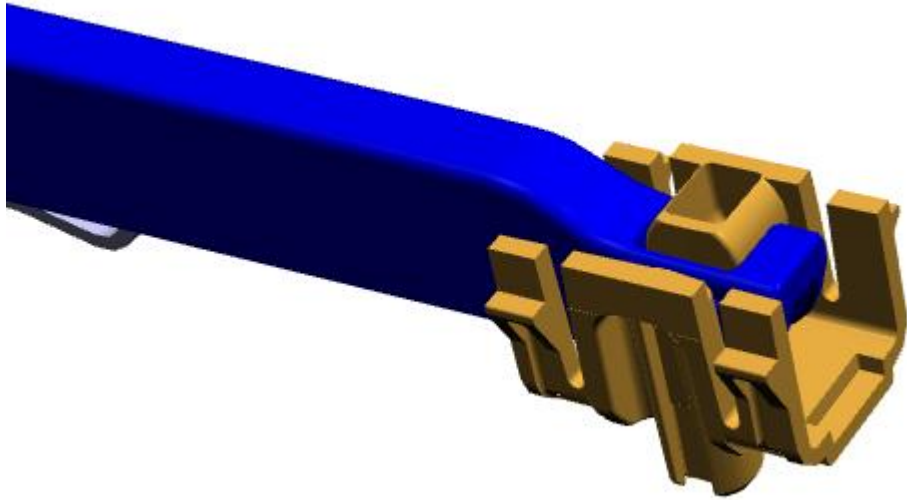

Situation: A creaking noise is present while the wind deflector raises/lowers. Sunroof may reverse due to anti-trap when closing.

Repair: Replace pivot point and wind deflector according to ISTA/AIR instructions REP 54 13 090

WIND DEFLECTOR EXCESS BUTYL

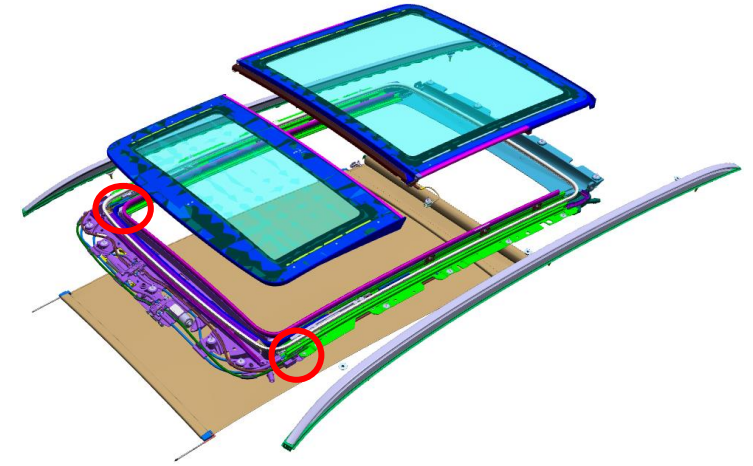
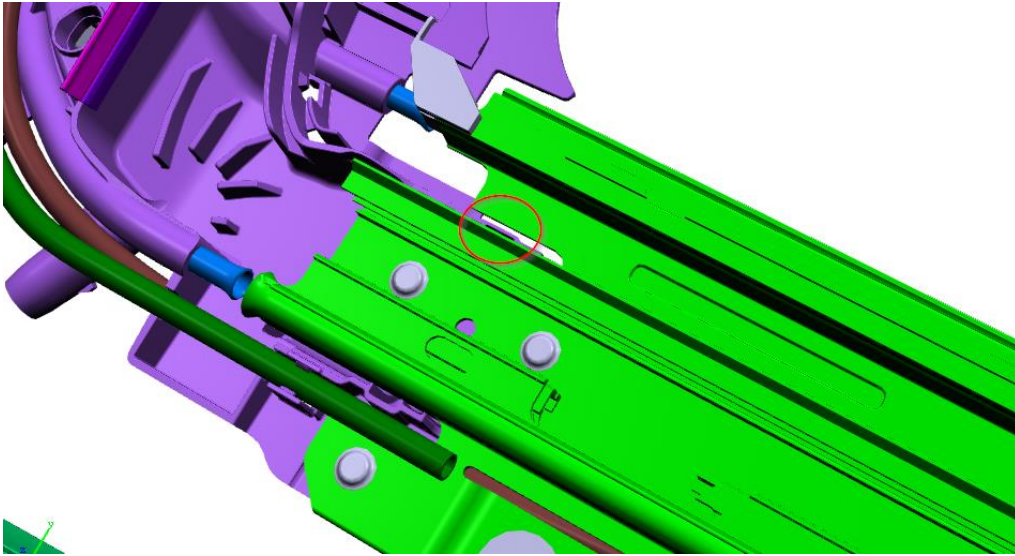

Picture of NOK (Before adjustment)

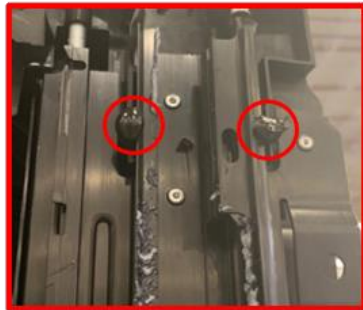

Picture of OK (After adjustment)



Situation: A popping noise is heard when the wind deflector raises/lowers.

Repair: Remove excess butyl to allow the wind deflector to move freely.

RELIEF CABLE TUBE NOT INSTALLED

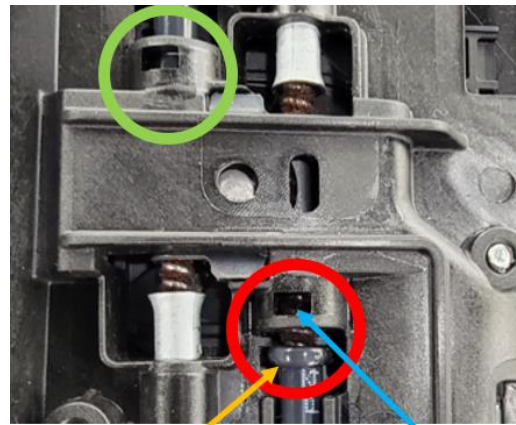
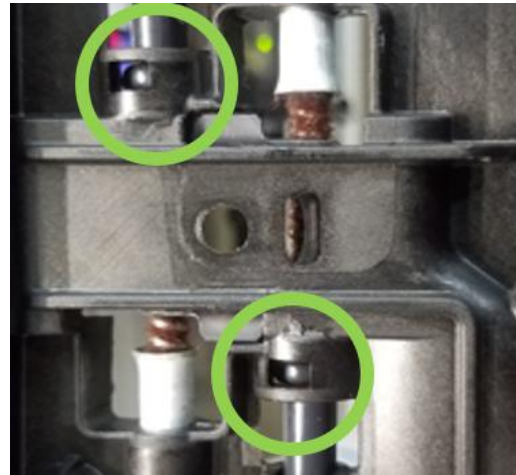
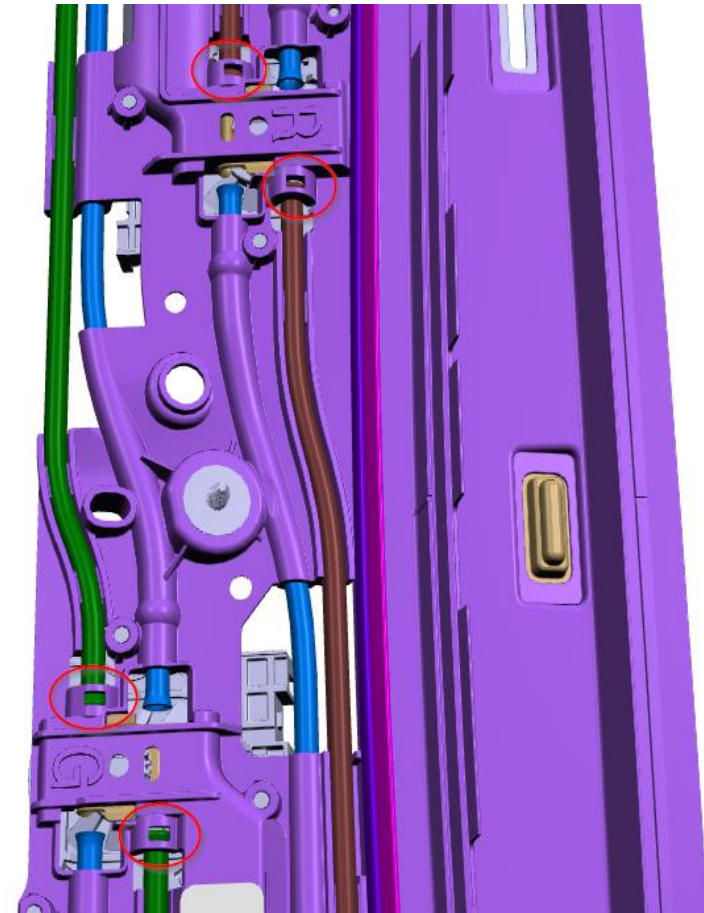

Bead not visible in window

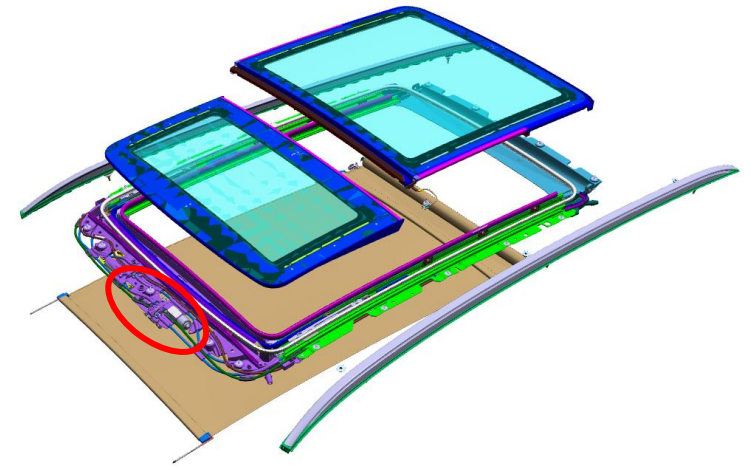

Situation: A humming / crackling noise is present when opening the glass or sunshade.

Repair: Replace frame according to ISTA/AIR instructions REP 54 13 261.



CABLE TUBE CLIP NOT INSTALLED

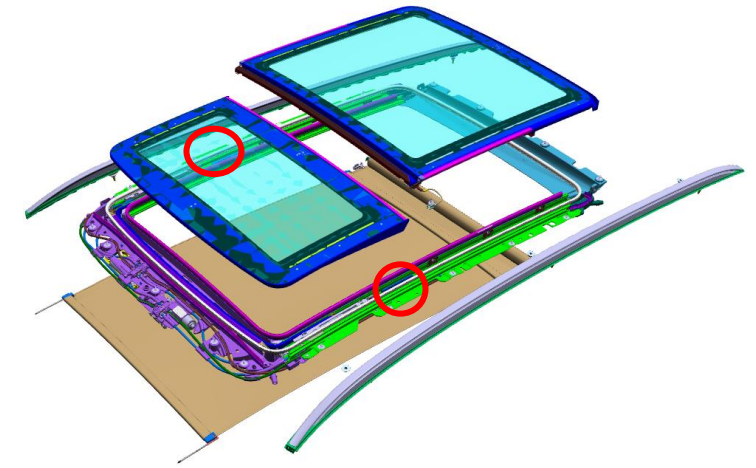
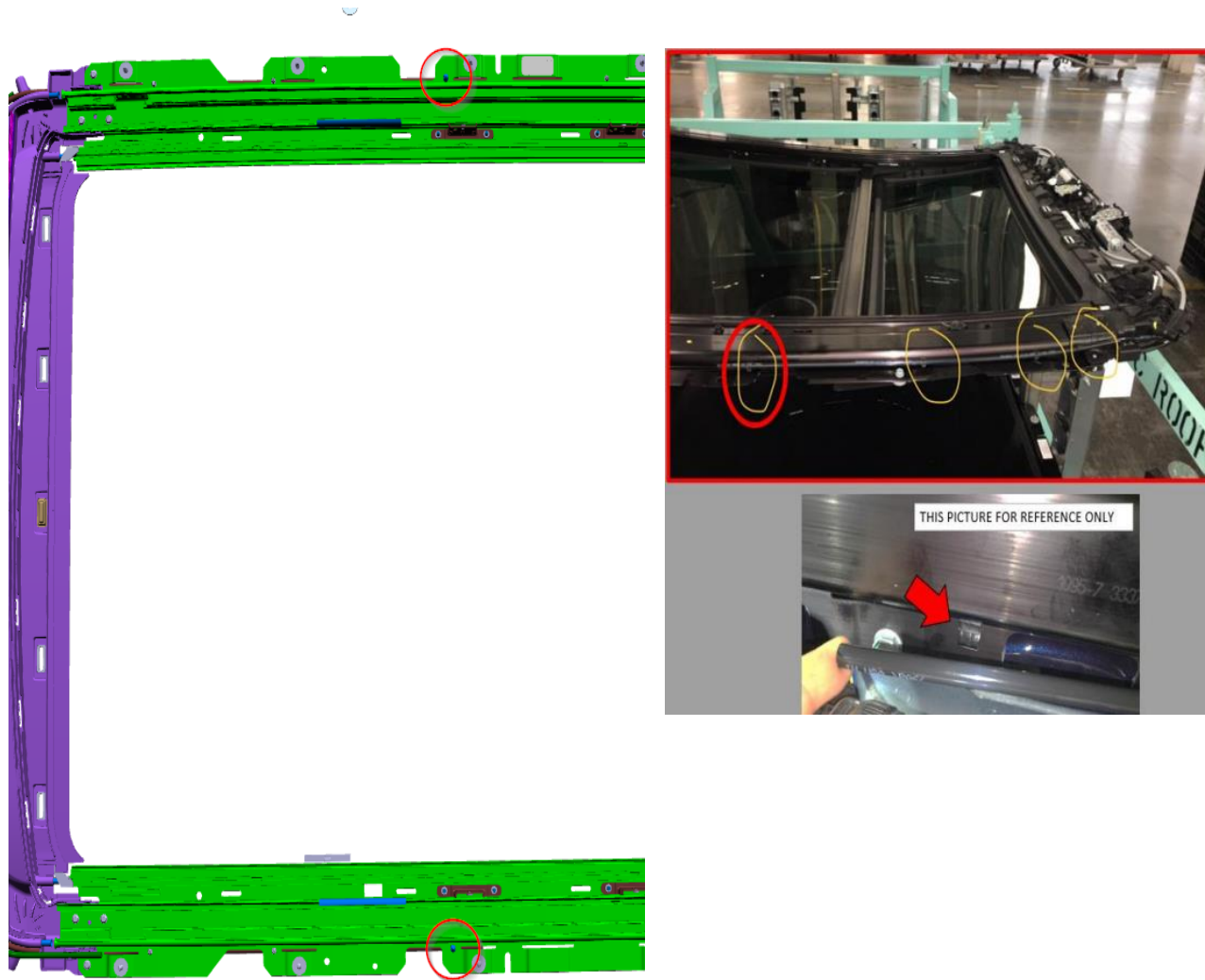

Situation: A humming / crackling noise is present when opening the sunshade or, a plastic rattling noise is heard while driving on rough road surfaces.

Repair: Reinstall the guide tube clip into the frame. If tube is damaged and noise persists then replace the frame according to ISTA/AIR instructions REP 54 13 261.



MECHANIC ARM BURR

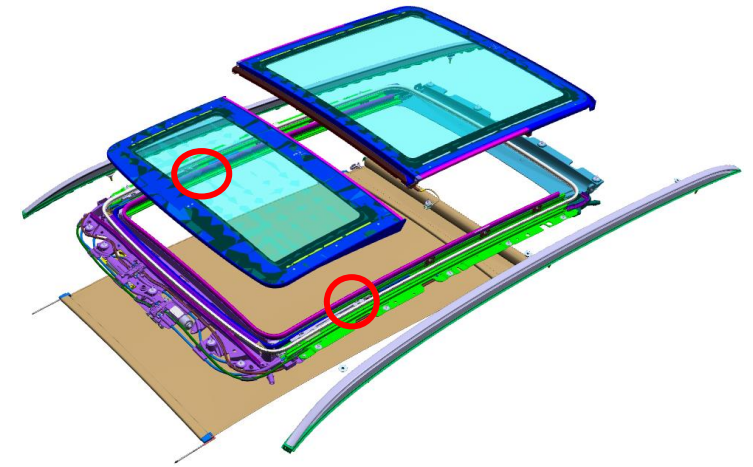
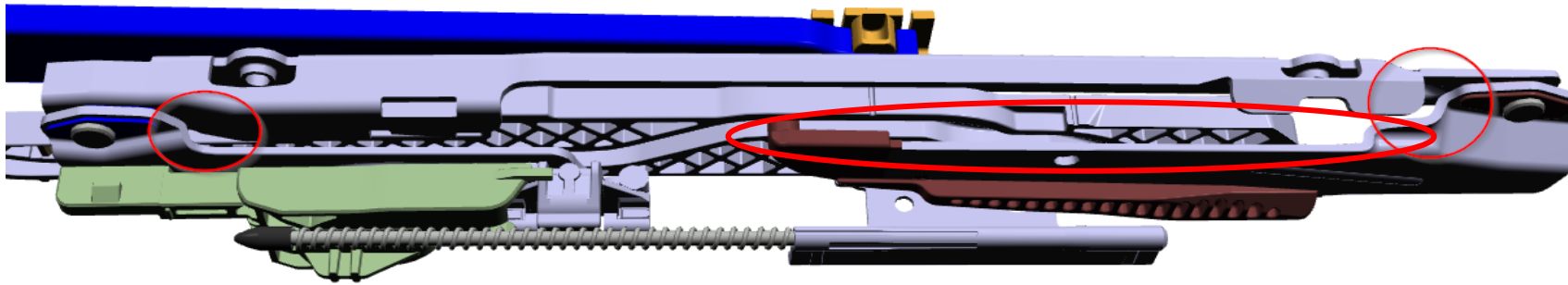

Situation: A clicking sound is present when the glass is opened to vent.

Repair: Inspect the pivot area for a burr and remove it if found. If the burr can't be found or it can't be repaired, replace the sunroof mechanisms according to ISTA/AIR instructions REP 54 13 515.



A PROBLEM NOT SHOWN HERE?

- If you are seeing issues on any of the Spartanburg built vehicles that aren't included here please send me an email with as many details as you can. We are working closely with Plant 10 to investigate emerging issues and trends and we want to know about new problems.
 - If you see a problem that's not included in the presentation- we probably have never seen it.
-

QUESTIONS?
