



STAR ONLINE PUBLICATION



Case Number: S2323000083 Rev. A

Release Date: November 2023

Symptom/Vehicle Issue: Buzz Squeak Rattle (BSR) From Interior Near Rear Header D Pillar With Body Twist Or Over Bumps.

Customer Complaint/Technician Observation: Customer may state there is a pop, clunk, snap, or creak noise that occurs from the rear of the vehicle in driving conditions that may induce body flex such as a driveway entrance, speed bumps or potholes.

Discussion: With the aid of a helper, drive the vehicle in the manner the customer states the noise can be duplicated. If the noise is loudest heard at the rear roof area on the left-hand side (Fig 1), review and perform the below procedure.

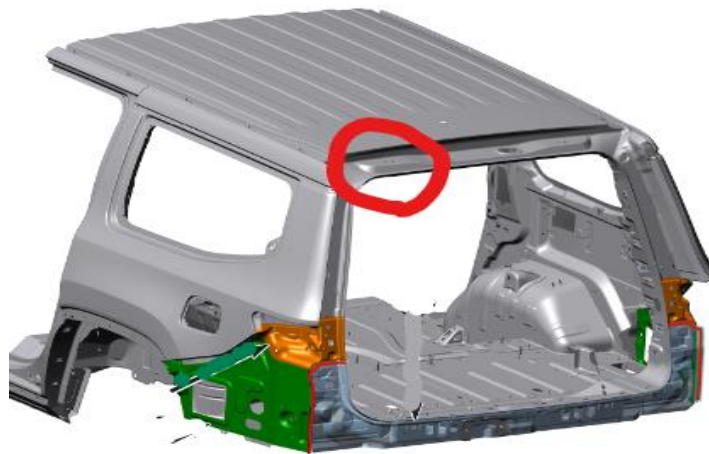

Fig 1

This document does not authorize warranty repairs. This communication documents a record of past experiences. STAR Online does not provide any conclusions about what is wrong with the vehicle. Rather, it captures all previous cases known that appear to be similar or related to the vehicle symptom / condition. You are the expert, and you are responsible for deciding on the appropriate course of action.

Contact STAR Center, or your Technical Assistance Center Via TechConnect, eCONTACT or Service Library entry if no solution is found.



STAR ONLINE PUBLICATION



1. If BSR noise heard is from the interior side of the red circled area in Fig 1, remove the headliner. Refer to Service Library 23 - Body / Interior / HEADLINER / Removal and Installation.
2. Lay a drop cloth on the interior at the lift gate opening to protect the interior carpet and trim from drips for the upcoming steps.
3. Obtain Loctite 290. Inspect the expiration date. **DO NOT USE EXPIRED MATERIAL.** Only use fresh 290.
4. Apply the Loctite 290 into the joint shown in Fig 2 below. Follow the application and cure instructions on the product. Because the application area is over head it may be of help to obtain an industrial material syringe also known as a hobby syringe (use internet web search to locate).
5. Once cured, assemble the interior in the reverse order of disassembly.
6. Perform a test drive to confirm condition is resolved.

This document does not authorize warranty repairs. This communication documents a record of past experiences. STAR Online does not provide any conclusions about what is wrong with the vehicle. Rather, it captures all previous cases known that appear to be similar or related to the vehicle symptom / condition. You are the expert, and you are responsible for deciding on the appropriate course of action.

Contact STAR Center, or your Technical Assistance Center Via TechConnect, eCONTACT or Service Library entry if no solution is found.



STAR ONLINE PUBLICATION

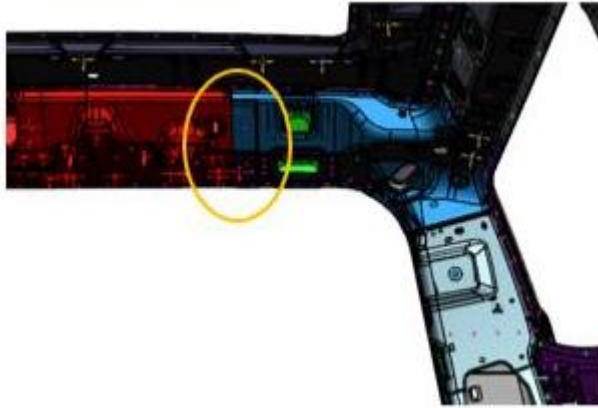

RH Side

LH Side

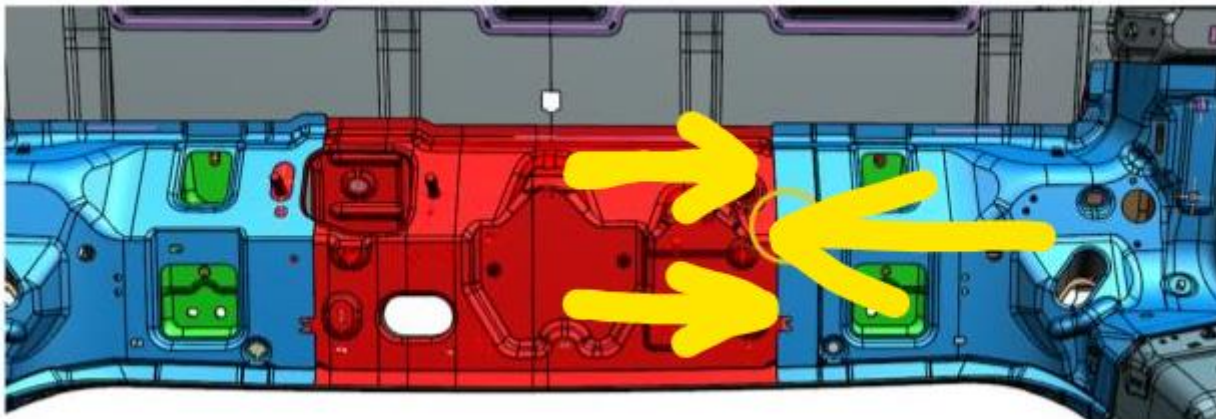

Figure 2.

Inject Loctite 290 into the seam indicated between the arrows (where the blue and red sections meet).

This document does not authorize warranty repairs. This communication documents a record of past experiences. STAR Online does not provide any conclusions about what is wrong with the vehicle. Rather, it captures all previous cases known that appear to be similar or related to the vehicle symptom / condition. You are the expert, and you are responsible for deciding on the appropriate course of action.

Contact STAR Center, or your Technical Assistance Center Via TechConnect, eCONTACT or Service Library entry if no solution is found.