

November 2023
SF678 A
(Revised December 2023)

Subject: Freightliner Snow Plow Light Harness

Models Affected: Specific model years 2022-2024 Freightliner 108SD and 114SD vehicles, manufactured November 9, 2021, through July 24, 2023.

General Information

REVISION: Work instructions have been revised starting with the note prior to step 35. Two parts have been added to the parts table which apply to the single plow connector configuration. The original terminals and seals only applied to the dual plow light connector configuration. Dealers should order all terminals and seals listed, although some will not be used depending on the configuration.

Daimler Truck North America LLC (DTNA), on behalf of its Freightliner Trucks division, is initiating Field Service Campaign SF678 to modify the vehicles mentioned above.

For certain vehicles, equipped with snow plows, the headlamps are inadvertently allowed to be active when the plow lights are active, resulting in the possibility of the headlamps reflecting off the rear of the plow, back towards the driver.

A new snow plow light harness and switch will be installed, and the lighting parameters will be updated to deactivate headlamps when the snow plow lights are activated.

There are approximately 179 vehicles involved in this campaign.

Additional Repairs

Dealers must complete all outstanding recall and field service campaigns prior to the sale or delivery of a vehicle. A dealer will be liable for any progressive damage that results from its failure to complete campaigns before sale or delivery of a vehicle.

Owners may be liable for any progressive damage that results from failure to complete campaigns within a reasonable time after receiving notification.

Please contact Warranty Campaigns for consideration of additional charges prior to performing the repair.

Work Instructions

Please refer to the attached work instructions. Prior to performing the campaign, check the vehicle for a completion sticker (Form WAR261).

Replacement Parts

Replacement parts are now available and can be obtained by ordering the part numbers listed below from your facing Parts Distribution Center (PDC).

If our records show your dealership has ordered any vehicle(s) involved in campaign number SF678, a list of the customers and vehicle identification numbers will be available on the DTNA Portal via OWL. Please refer to this list when ordering parts for this campaign.

November 2023
SF678 A
(Revised December 2023)

Table 1 - Replacement Parts for SF678

Campaign Number	Part Number	Part Description	Qty.
SF678 A	A66-14104-040	SW-MSF,HWD,PLOW LIGHT	1 ea
	TSU CT44FRT033	PLOW LIGHT DASH HARN (Fig. 1)	1 ea
	TSU CT44FRT034	PLOW INTERFACE GND CHAS HARN (Fig. 2)	1 ea
	PAC 12045773 L	TERMINAL (Dual-Plow)	2 ea
	PAC 15324973 B	SEAL-CABLE (Dual-Plow)	2 ea
	PAC 12110847 L	TERMINAL (Single-Plow)	1 ea
	PAC 15324984 B	SEAL-CABLE (Single Plow)	1 ea
	BUS BK/ATM 5	FUSE - MINI, 5AMP, MP280	1 ea (use dealer stock)
	WAR261	BLANK COMPLETION STICKER	1 ea

Table 1

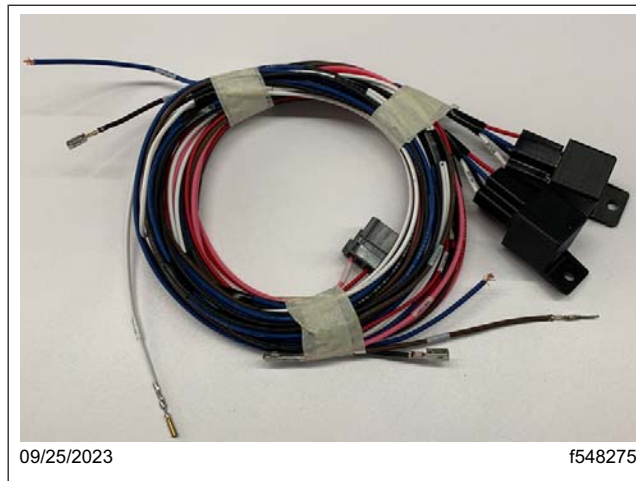

Fig. 1, Inside Cab Dash Harness (TSU CT44FRT033)



Fig. 2, Underhood Plow Harness (TSU CT44FRT034)

November 2023
SF678 A
(Revised December 2023)

Removed Parts

U.S. and Canadian Dealers, please follow Warranty Failed Parts Tracking shipping instructions for the disposition of all removed parts. Export distributors, please destroy removed parts unless otherwise advised.

Labor Allowance

Table 2 - Labor Allowance

Campaign Number	Procedure	Time Allowed (hours)	SRT Code	Corrective Action
SF678 A	Install Light Harness & Switch, Update Lighting Parameters	4.5	996-F173A	12-Repair Recall/Campaign

Table 2

IMPORTANT: When the campaign has been completed, locate the base completion label in the appropriate location on the vehicle, and attach the gray completion sticker provided in the field service kit (Form WAR261). If the vehicle does not have a base completion label, clean a spot on the appropriate location of the vehicle and first attach the base completion label (Form WAR259). If a field service kit is not required or there is no completion sticker in the kit, write the campaign number on a blank sticker and attach it to the base completion label.

Claims for Credit

You will be reimbursed for your parts, labor, and handling (landed cost for Export Distributors) by submitting your claim through the warranty system within 30 days of completing this campaign. Please reference the following information in OWL:

- Claim type is **Field Service Campaign**.
- In the Campaign field, enter the campaign number and appropriate condition code (**SF678-A**).
- In the Primary Failed Part field, enter **25-SF678-000**.
- In the Parts section, enter the appropriate part numbers as shown in the Replacement Parts Table.
- In the Labor section, enter the appropriate SRT from the Labor Allowance Table. Administrative time will be included automatically as SRT 939-6010A for 0.3 hours.
- The VMRS Component Code is **F99-999-005** and the Cause Code is **A1 - Campaign**.
- This Field Service Campaign will **terminate on November 30, 2024**. Dealers will be notified of any changes to the termination date via an Important Campaign Information Letter (ICI) posted on the DTNA Portal.

IMPORTANT: OWL must be viewed prior to beginning work to ensure the vehicle is involved and the campaign has not previously been completed. Also, check for a completion sticker before beginning work.

All claims must be submitted within 30 days of the repair and within 30 days of the termination date of the campaign. U.S. and Canadian Dealers: All excess inventory to be returned to the PDC following the conclusion of the campaign must be returned in resaleable condition to the Memphis PDC within 90 days from the termination date. Please submit a PAR to request return to the Memphis PDC. (Canadian dealers should return the kits to their facing PDC.) Export Distributors: Excess inventory is not returnable.

For questions, U.S. and Canadian dealers, contact the Warranty Campaigns Department using the Warranty Support Center (WSC) app located on the DTNA Portal. Export distributors submit a WSC inquiry or contact your International Service Manager.

November 2023
SF678 A

Copy of Notice to Owners

Subject: Freightliner Snow Plow Light Harness

Daimler Truck North America LLC (DTNA), on behalf of its Freightliner Trucks division, is initiating Field Service Campaign SF678 to modify specific model years 2022-2024 Freightliner 108SD and 114SD vehicles, manufactured November 9, 2021, through July 24, 2023.

For certain vehicles, equipped with snow plows, the headlamps are inadvertently allowed to be active when the plow lights are active, resulting in the possibility of the headlamps reflecting off the rear of the plow, back towards the driver.

A new snow plow light harness and switch will be installed, and the lighting parameters will be updated to deactivate headlamps when the snow plow lights are activated.

Please contact an authorized DTNA dealer to arrange to have the campaign performed and to ensure that parts are available at the dealership. The campaign will take approximately four and one half hours and will be performed **free of charge**. To locate an authorized dealer, search online at northamerica.daimlertruck.com/contact-us. Scroll down to "Locate a Dealer," and select the appropriate brand.

This Field Service Campaign will **terminate on November 30, 2024**. Please make sure the campaign is completed prior to this date. Work completed after this date will be done at the customer's expense.

As stated in the terms of your express limited warranty, DTNA will not pay for any damage caused by failure to properly maintain your vehicle. DTNA considers the work necessary under this campaign to be proper maintenance and will, therefore, not pay for any damage to your vehicle caused by your failure to have the repairs that are the subject of this campaign performed in a reasonable time.

If you have any questions, contact the Warranty Campaigns Department at (800) 547-0712, 7 a.m. to 4 p.m. Pacific Time, Monday through Friday, e-mail address DTNA.Warranty.Campaigns@DaimlerTruck.com, or contact the Customer Assistance Center at (800) 385-4357.

WARRANTY CAMPAIGNS DEPARTMENT

Enclosure

November 2023
SF678 A
(Revised December 2023)

Work Instructions

Subject: Freightliner Snow Plow Light Harness

Models Affected: Specific model years 2022-2024 Freightliner 108SD and 114SD vehicles, manufactured November 9, 2021, through July 24, 2023.

Snow Plow Light Harness

REVISION: Work instructions have been revised starting with the note prior to step 35. Two parts have been added to the parts table which apply to the single plow connector configuration. The original terminals and seals only applied to the dual plow light connector configuration. Dealers should order all terminals and seals listed, although some will not be used depending on the configuration.

The instructions that follow involve installation of wiring harnesses in the dash and the engine compartment to modify the headlight function so that the headlights are interrupted when the plow lights are turned on. To aid in visualizing the repair, see the plow light wiring modification schematics shown in [Fig. 3](#), page 6.

NOTE: The inside cab dash harness TSU CT44FRT033, shown in [Fig. 1](#), page 2 and below, was originally designed for another vehicle model. It will work on Business Class M2 Plus, but due to routing differences, there will be considerable additional length of wiring in some of the circuits. It will be necessary to either bundle and secure the additional harness length, or cut the wires short as needed. It also may be necessary to untape some portions of the harness to gain the length needed to route the wiring.

NOTE: The brown wire in the harness (TSU CT44FRT033) will not be used in this installation.

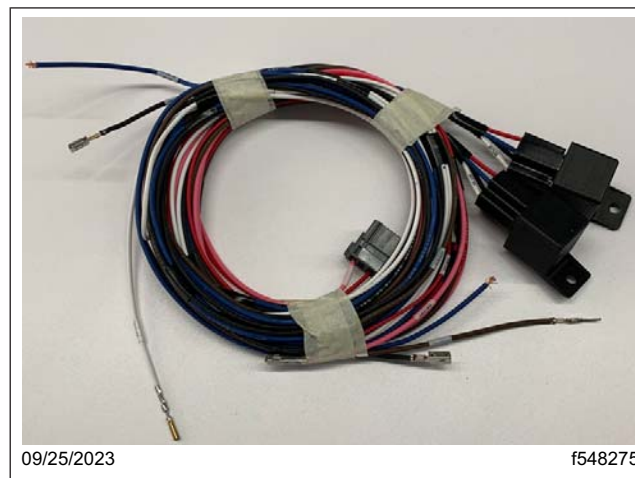

Fig. 1, Inside Cab Dash Harness (TSU CT44FRT033)

November 2023
SF678 A
(Revised December 2023)

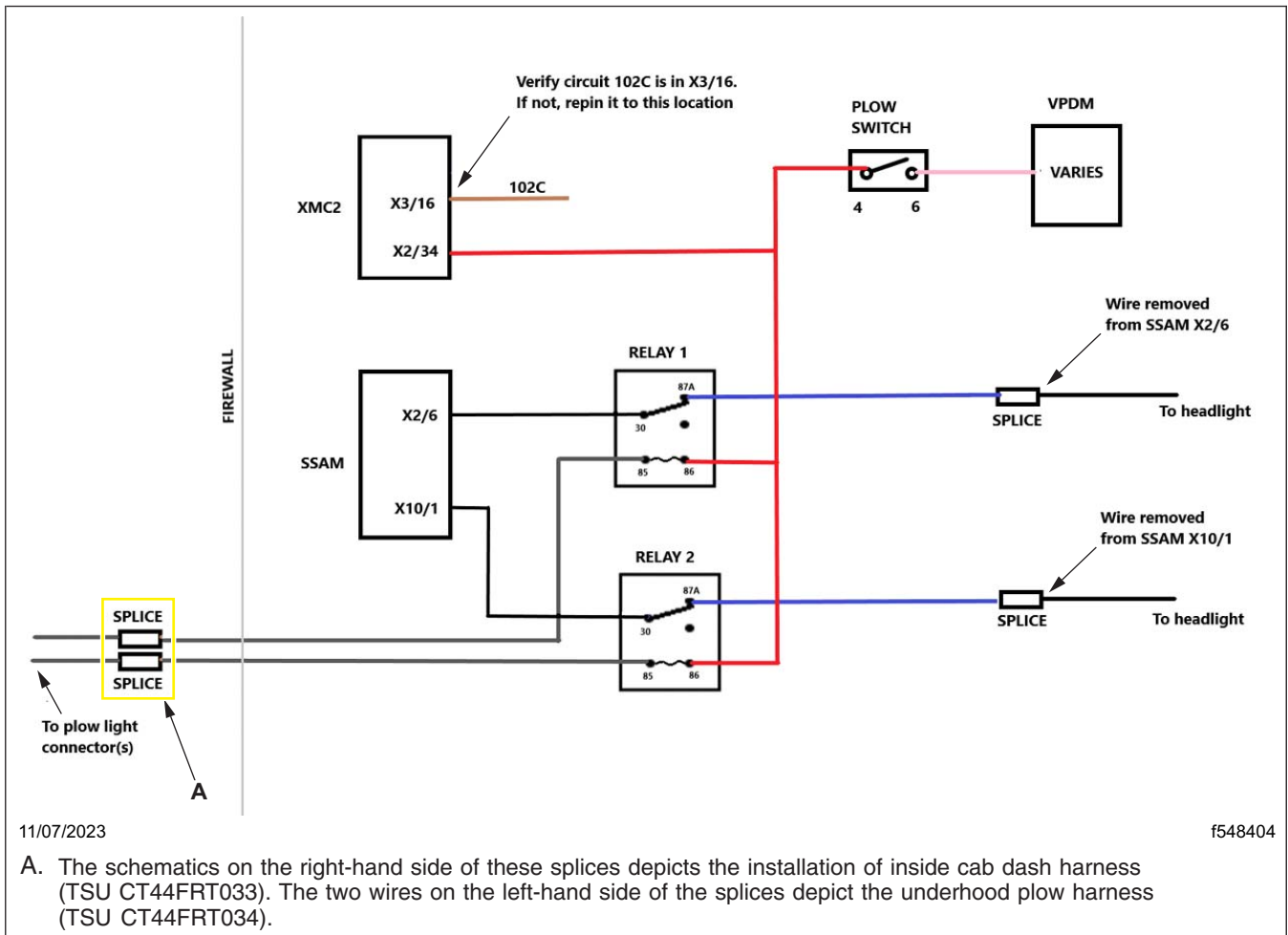

Fig. 3, Schematic - Snow Plow Light Wiring Modification

1. Check the base label (Form WAR259) for a completion sticker for SF678 (Form WAR261), indicating this work has been done. The base label is usually located on the passenger-side door, about 12 inches (30 cm) below the door latch. If a completion sticker is present, no work is needed. If a completion sticker is not present, proceed to the next step.
2. Park the vehicle on a level surface, shut down the engine, and set the parking brake. Chock the tires.
3. Disconnect the battery cables.
4. Follow the substeps to remove the dash covers. For more information, see **Section 60.08** of the *Business Class M2 Plus Workshop Manual*.

November 2023
SF678 A
(Revised December 2023)

4.1 Remove the passenger-side lower access cover. See [Fig. 4](#).



Fig. 4, Passenger-Side Lower Access Cover

4.2 Remove the passenger-side upper dash fascia. See [Fig. 5](#).



Fig. 5, Passenger-Side Upper Dash Fascia

November 2023
SF678 A
(Revised December 2023)

- 4.3 Remove the upper center fascia panel. Remove the power receptacle harness from the socket.
See Fig. 6.



Fig. 6, Upper Center Fascia Panel

- 4.4 Remove the dash top tray. See **Fig. 7.**



Fig. 7, Dash Top Tray

November 2023
SF678 A
(Revised December 2023)

- 4.5 Remove the footwell lamp and diagnostic connector retaining nut from the driver-side lower dash cover, then remove the driver-side lower dash cover. See [Fig. 8](#).



Fig. 8, Driver-Side Lower Dash Cover

- 4.6 Remove the park brake knobs.
- 4.7 Remove the steering column cover.
- 4.8 Remove the driver-side upper dash fascia. See [Fig. 9](#).

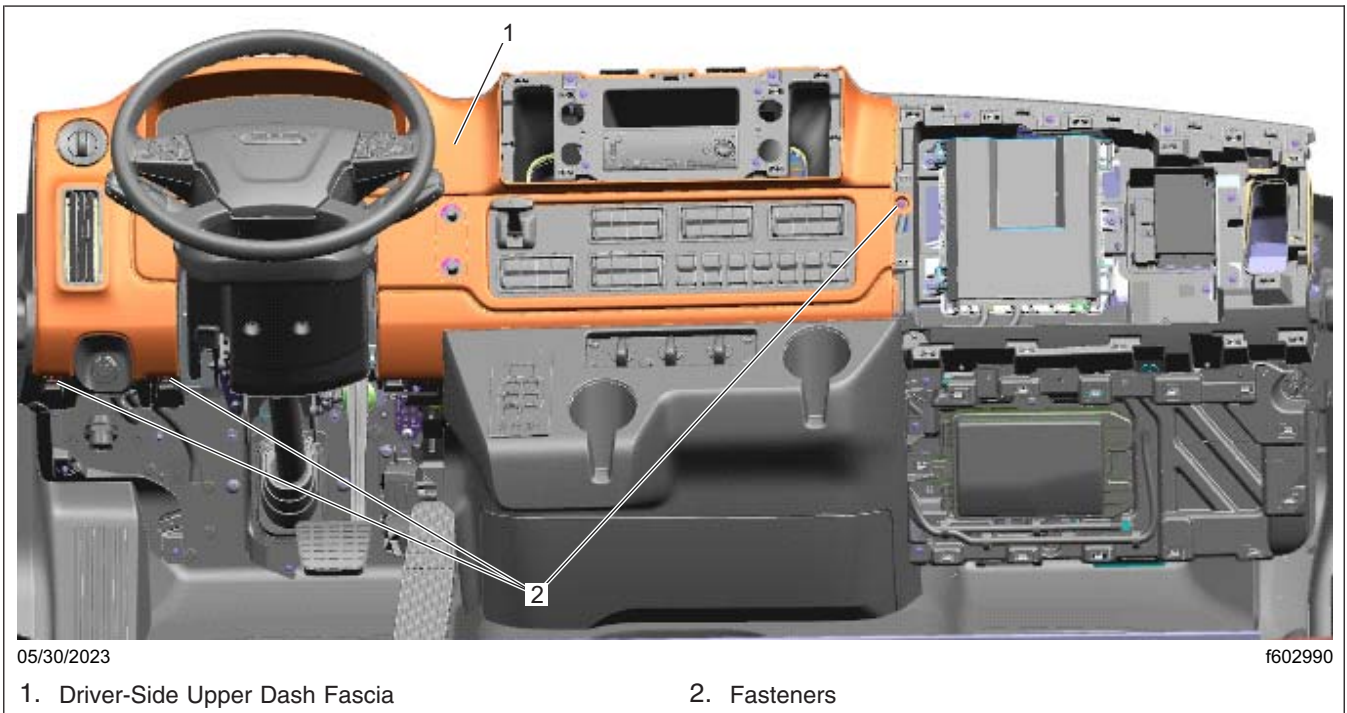

Fig. 9, Driver-Side Upper Dash Fascia

November 2023
SF678 A
(Revised December 2023)

4.9 Remove the lower dash cover. See [Fig. 10](#).

NOTE: If the vehicle does not have a removable lower cover, as shown in [Fig. 10](#), the center dash panel (doghouse) has to be removed. For instructions to remove the center dash panel, see [Section 60.08](#) of the *Business Class M2 Plus Workshop Manual*.

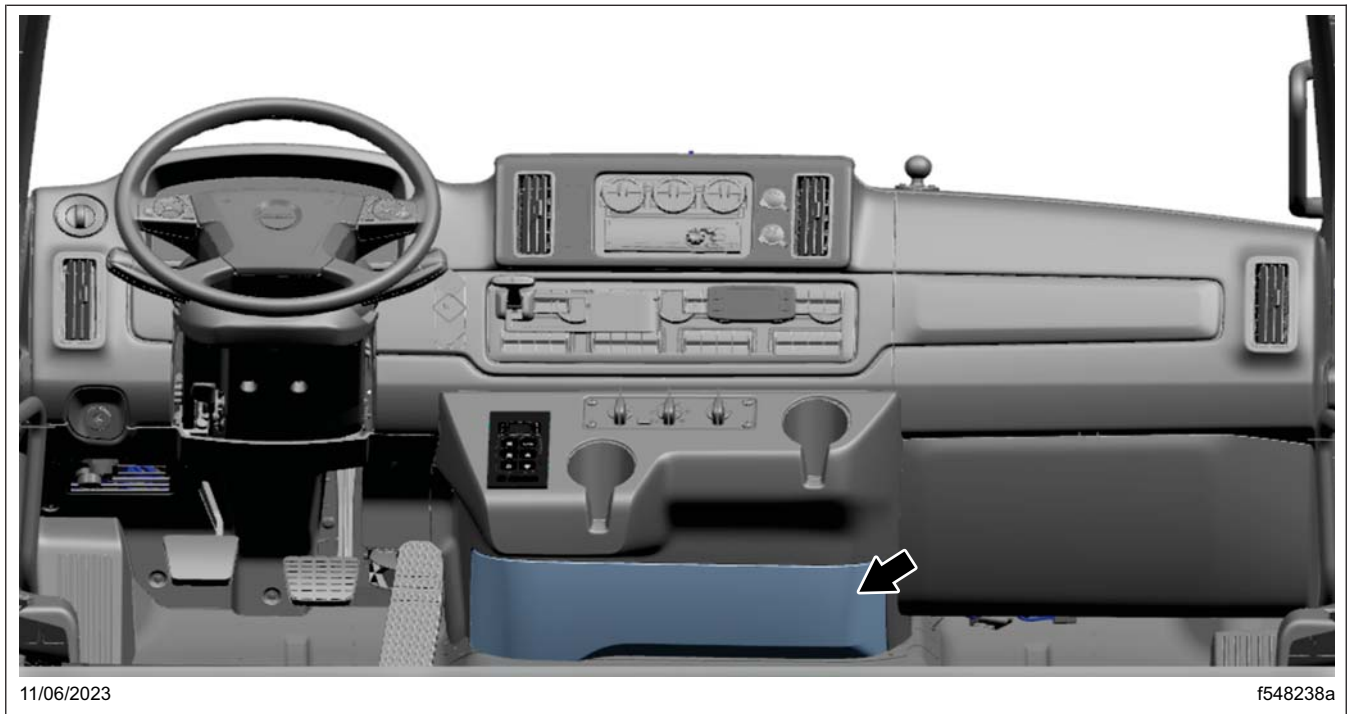

Fig. 10, Lower Dash Cover

November 2023
SF678 A
(Revised December 2023)

NOTE: The switch panel does not need to be completely removed, it can be laid aside with some or all the wiring attached. It is only necessary to gain access behind the panel.

- 4.10 Remove the center dash switch panel containing the modular switch field (MSF) switches.
[See Fig. 11.](#)



Fig. 11, Center Dash Switch Panel

November 2023
SF678 A
(Revised December 2023)

5. Remove the interior vehicle power distribution module (VPDM), shown in [Fig. 12](#). For instructions, see [Section 54.06, Subject 100](#) of the *Business Class M2 Plus Workshop Manual*.



Fig. 12, Interior VPDM

6. Begin routing the harness (TSU CT44FRT033) starting from behind the center dash switch panel shown in [Fig. 13](#).

NOTE: The two relays and the portion of wiring with the 6-pin connector (pink and red wire) will remain in the space behind the center dash switch panel.

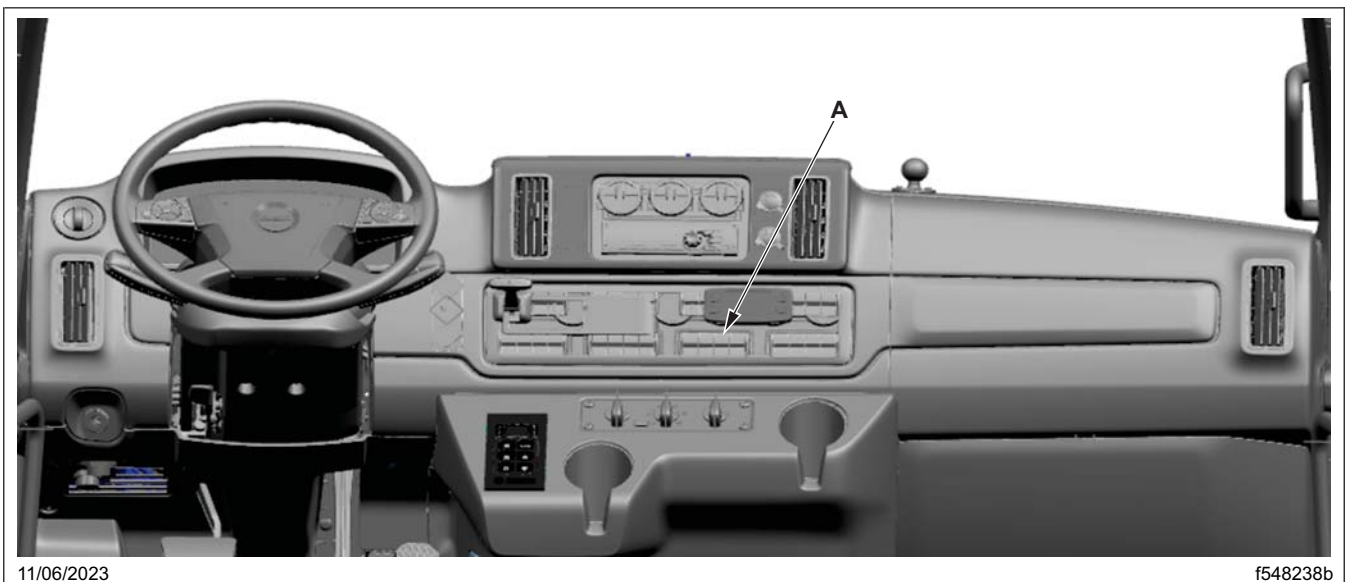

- A. Begin routing of the dash harness in the space behind the center dash switch panel.

Fig. 13, Dash Harness Routing Starting Point

November 2023
SF678 A
(Revised December 2023)

7. Route the two blue and two black wires to the SSAM in the path shown in [Fig. 14](#) and [Fig. 15](#).

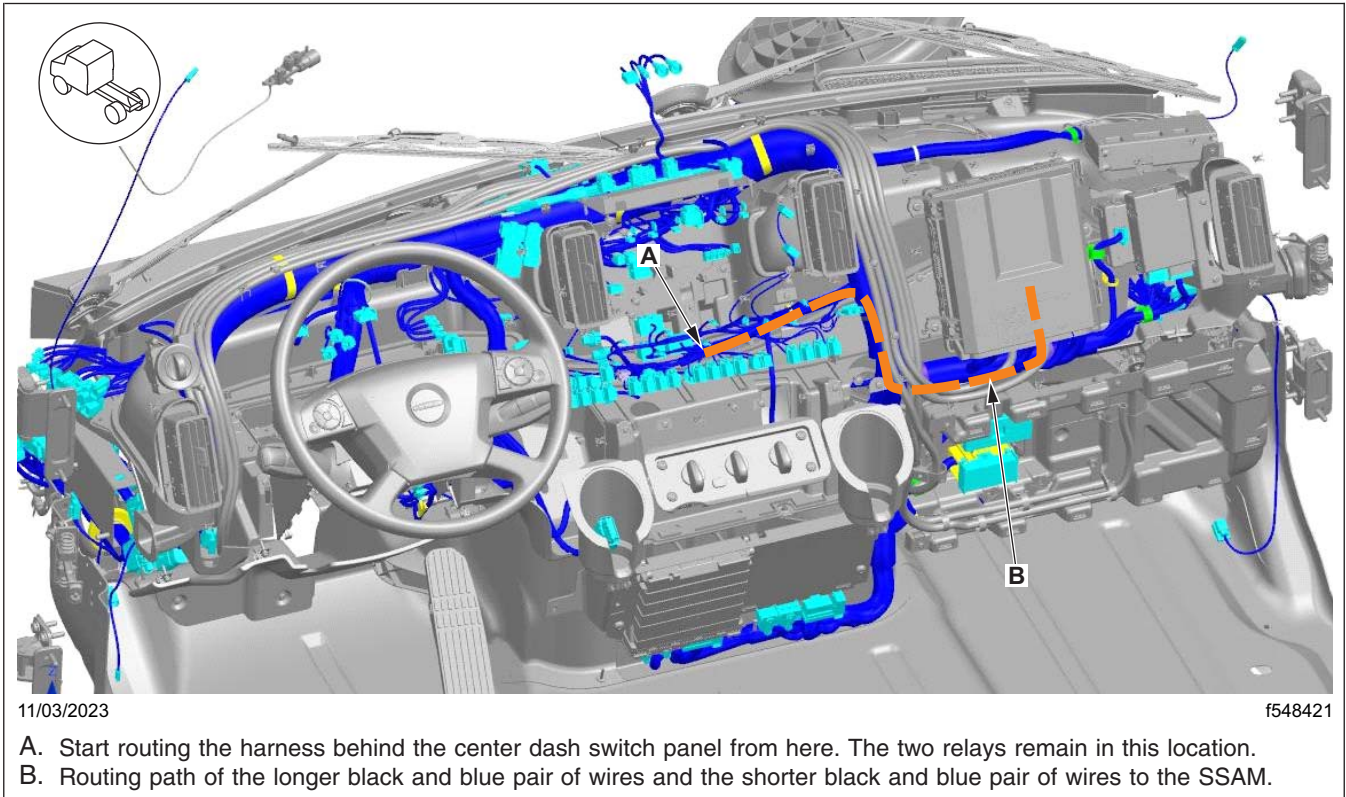

Fig. 14, Routing of the Two Black and Blue Wire Pairs to the SSAM

November 2023
SF678 A
(Revised December 2023)

IMPORTANT: There is a shorter blue and black pair of wires, and a longer blue and black pair. The longer blue and black pair of wires has to be routed to the SSAM X10 connector. The shorter blue and black pair of wires has to be routed to the SSAM X2 connector.

IMPORTANT: It is critical that the two longer wires that originate at relay 2 get terminated at the SSAM X10 connector and the shorter wires that originate at relay 1 get terminated at the SSAM X2 connector.

NOTE: There will be excess wiring. The excess wiring should be bundled up and secured behind the center dash switch panel.

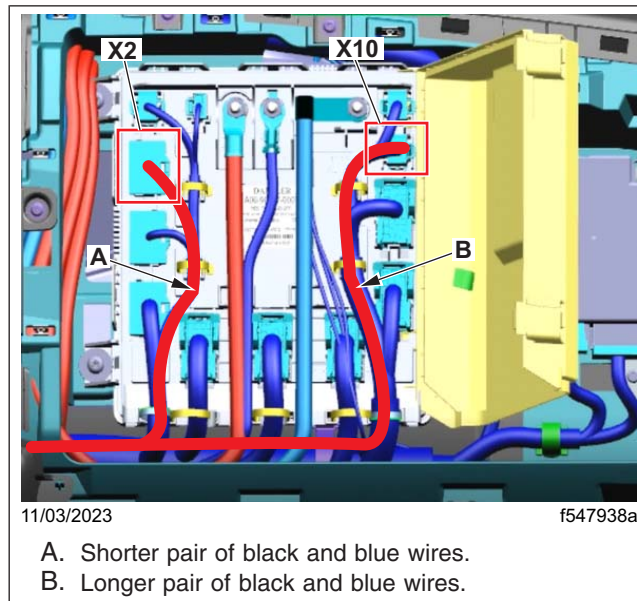

Fig. 15, Routing of the Longer and Shorter Pair of Black and Blue Wires to the SSAM

November 2023
SF678 A
(Revised December 2023)

8. Remove the wire from pin 1 of the SSAM X10 connector and replace it with the longer black wire. Splice the wire removed from pin 1 of the SSAM X10 connector to the longer blue wire.

8.1 Remove the X10 connector from the SSAM. See [Fig. 16](#).

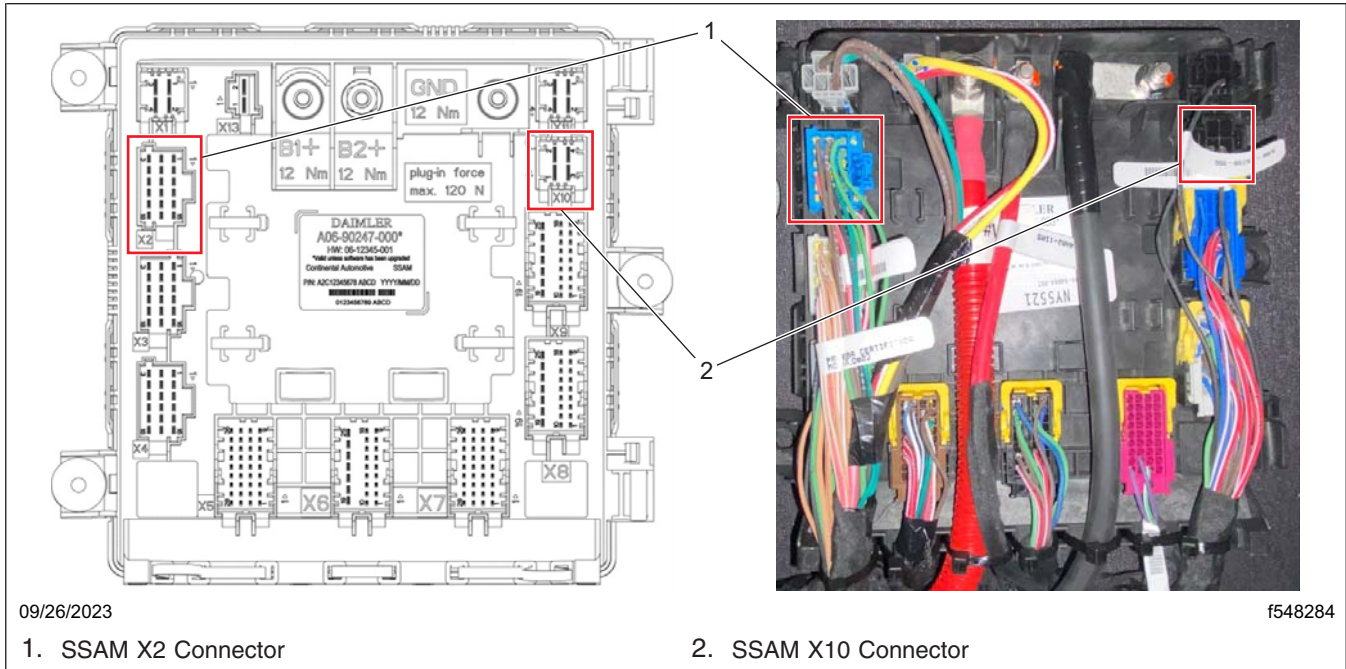

Fig. 16, Location of the SSAM X10 and X2 Connectors

8.2 Locate pin 1 of the X10 connector. See [Fig. 17](#).

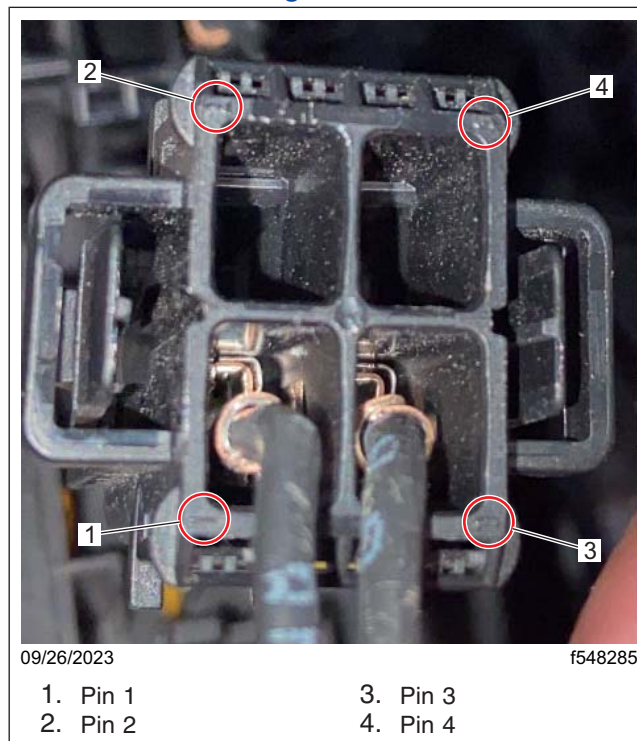

Fig. 17, SSAM X10 Connector Pin Locations

November 2023
SF678 A
(Revised December 2023)

- 8.3 Gently pry the locking tab with a small flat screwdriver in the location, shown in **Fig. 18**, to unlock the side of the connector that coincides with pin 1. **Figure 19** shows the tab in the unlocked position.

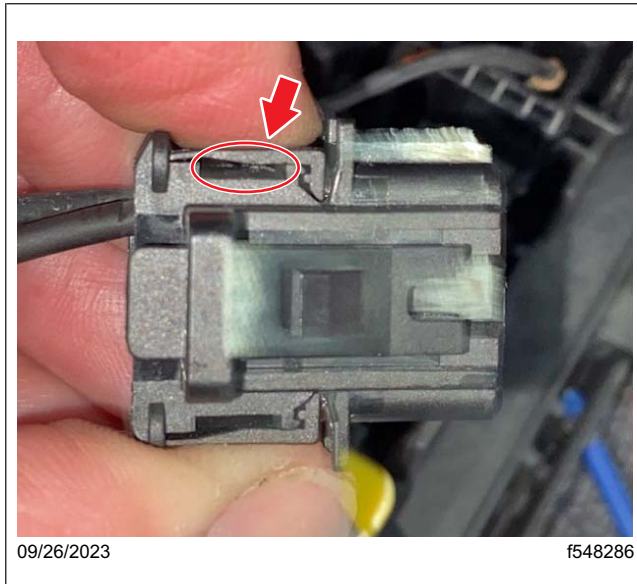

Fig. 18, SSAM X10 Connector Locking Tab

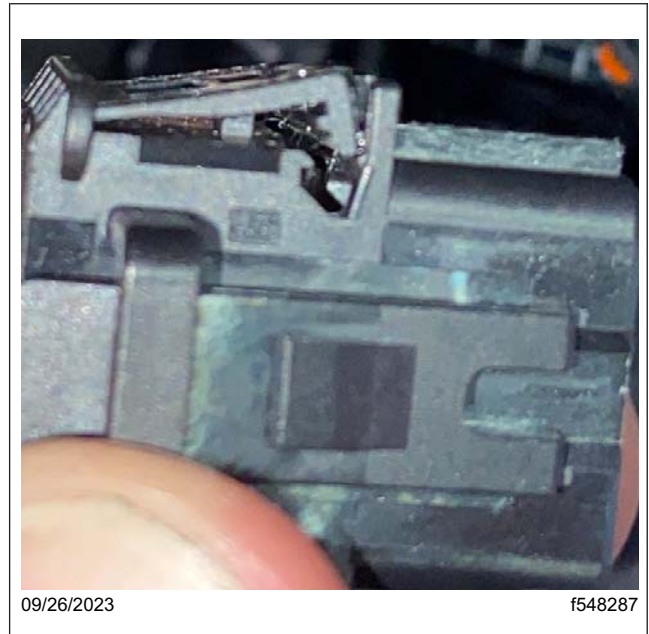

Fig. 19, SSAM X10 Connector Locking Tab in the Unlocked Position

- 8.4 Use a two-prong pin removal tool to remove the wire from cavity 1 of the SSAM X10 connector. **See Fig. 20.**

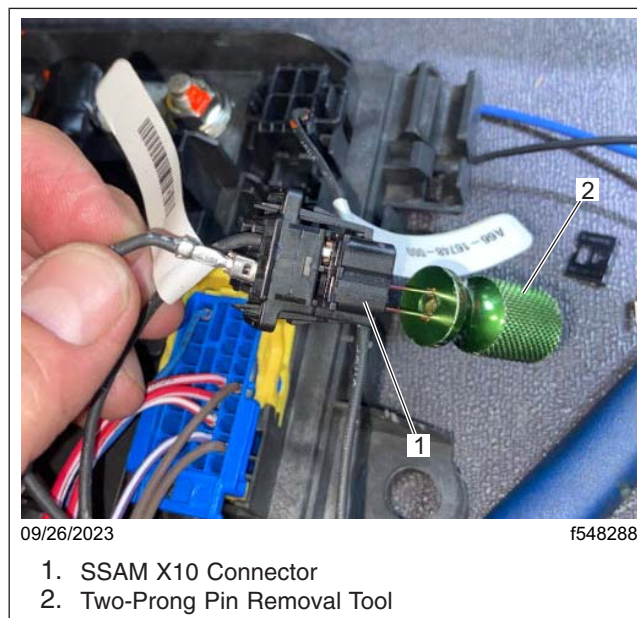

Fig. 20, Removing the Wire Using Two-Prong Pin Removal Tool

November 2023
SF678 A
(Revised December 2023)

8.5 Insert the longer black wire that was routed to the X10 connector in step 7 into cavity 1 of the X10 connector. See [Fig. 21](#) .

NOTE: The longer black wire should already have a terminal attached. If not, crimp the terminal (23-13209-302) on to that wire prior to inserting it into cavity 1 of the SSAM X10 connector.

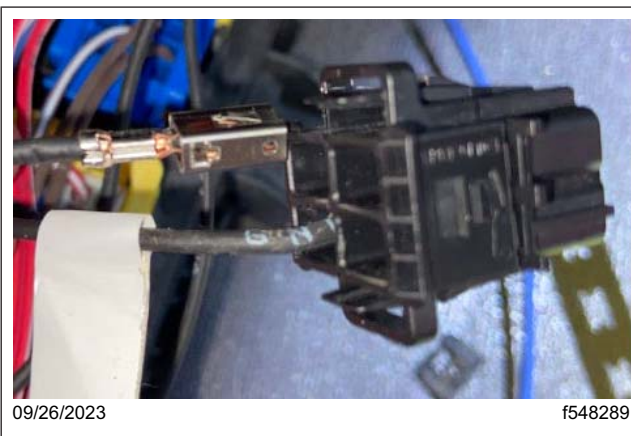

Fig. 21, Inserting the Longer Black Wire into Cavity 1 of the X10 Connector

8.6 Lock the X10 connector. See [Fig. 22](#).

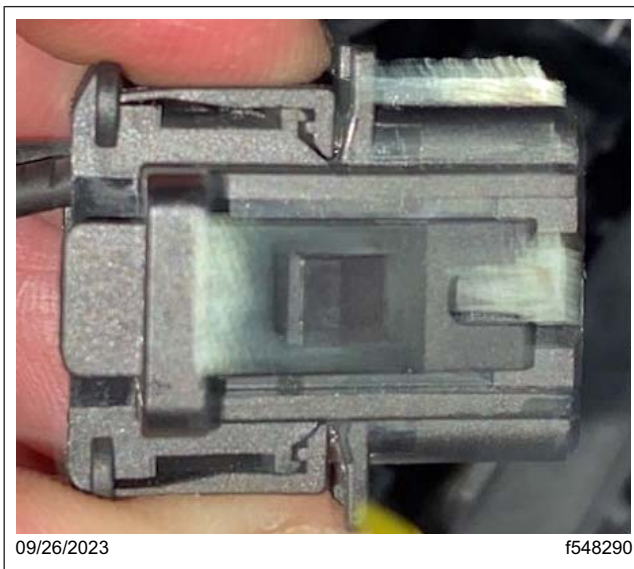

Fig. 22, SSAM X10 Connector Locked

November 2023
SF678 A
(Revised December 2023)

- 8.7 On the wire that was removed from cavity 1 of the SSAM X10 connector in substep 8.4, cut the terminal off and strip the wire. See [Fig. 23](#).



Fig. 23, Cutting Off the Terminal

- 8.8 Splice the wire removed from cavity 1 of the SSAM X10 connector to the longer blue wire that was routed to the X10 connector in step 7. See [Fig. 24](#).

NOTE: For wire splices, use one of the methods outlined in **Section 54.00, Subjects 100 and 110** of the *Business Class M2 Plus Workshop Manual*.

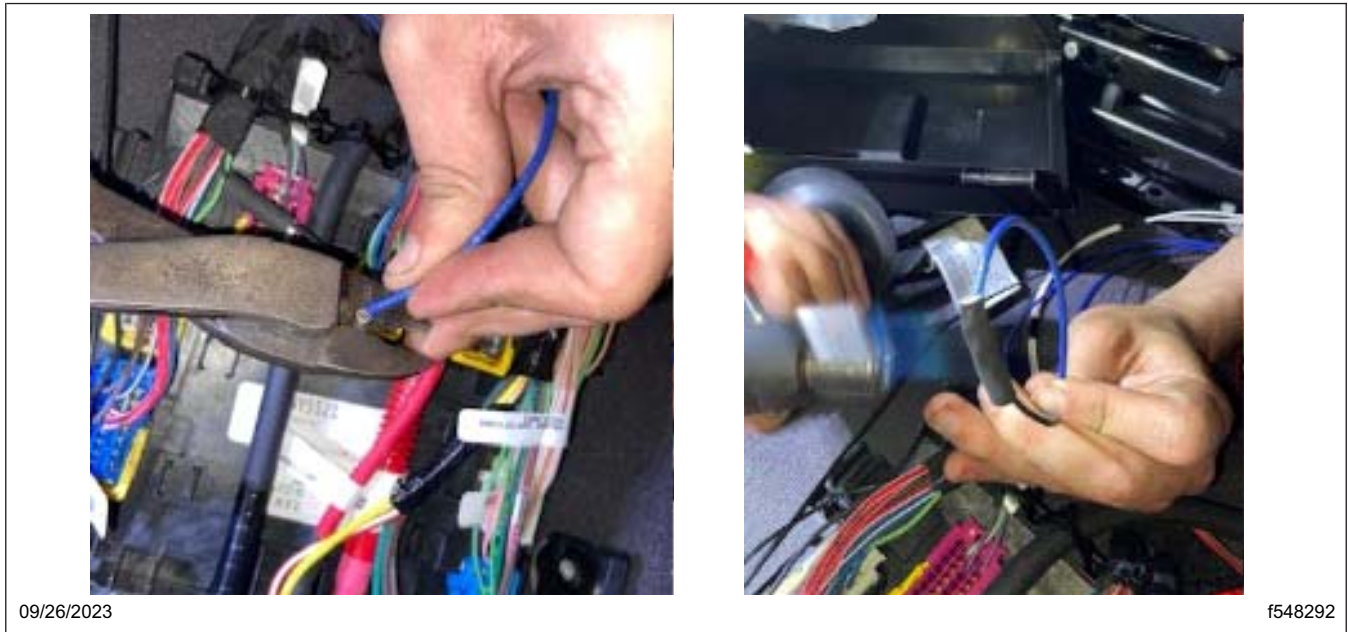

Fig. 24, Splicing the Wire

November 2023
SF678 A
(Revised December 2023)

- 8.9 Plug the X10 connector back in the SSAM. See [Fig. 25](#) .
9. Remove the wire from pin 6 of the SSAM X2 connector, and replace it with the shorter black wire. Splice the wire removed from pin 6 of the SSAM X2 connector to the shorter blue wire.
- 9.1 Remove the X2 connector from the SSAM. See [Fig. 16, page 15](#).
- 9.2 Gently pry up on the yellow locking tab of the X2 connector as shown in [Fig. 26](#). Note that the lock does not come all the way out.

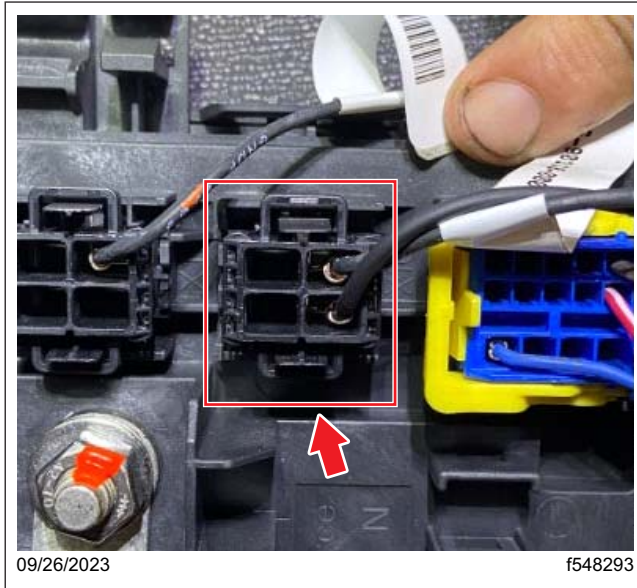

Fig. 25, X10 Connector Plugged into the SSAM

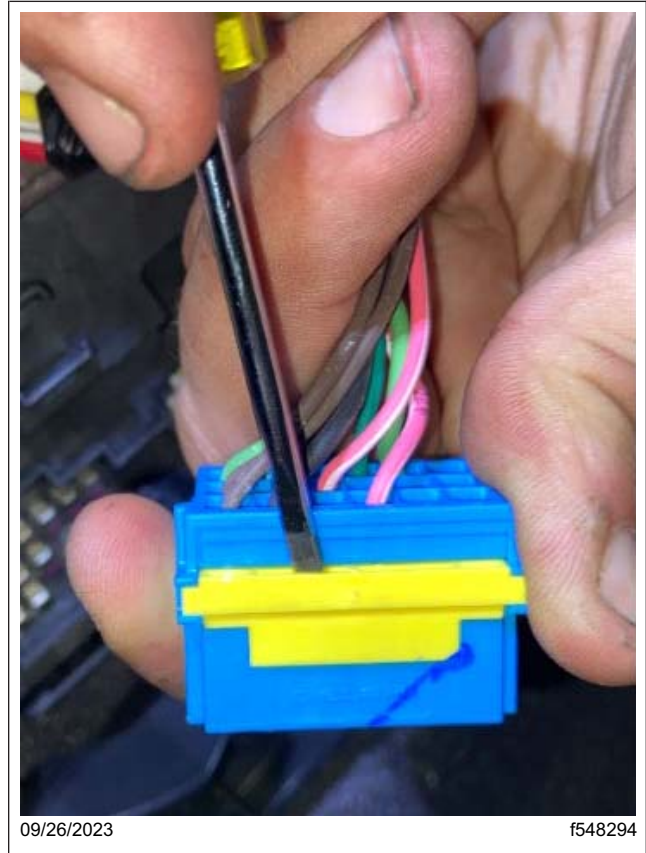

Fig. 26, Releasing the Lock on the SSAM X2 Connector

November 2023
SF678 A
(Revised December 2023)

9.3 Use a two-prong pin removal tool to remove the wire from cavity 6 of the SSAM X2 connector.
See Fig. 27 and Fig. 28.

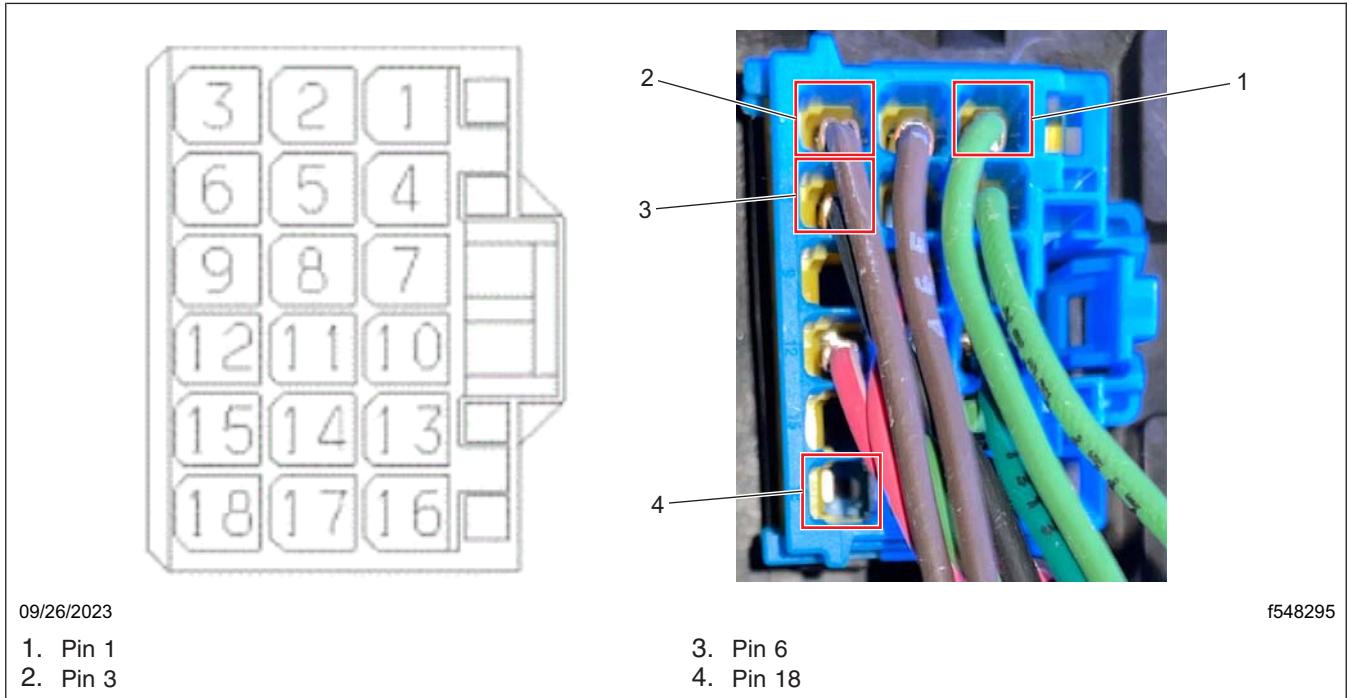

Fig. 27, SSAM X2 Connector Pin Locations

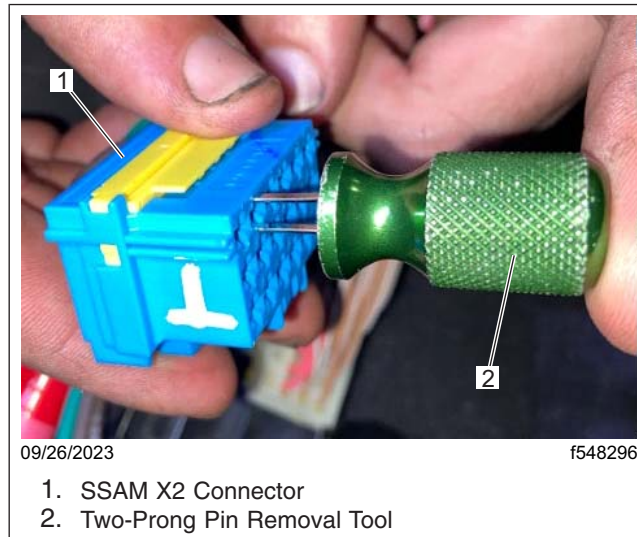

Fig. 28, Removing the Wire Using Two-Prong Pin Removal Tool

November 2023
SF678 A
(Revised December 2023)

- 9.4 Insert the shorter black wire, previously routed to the SSAM X2 connector in step 7, into cavity 6 of the SSAM X2 connector. See **Fig. 29**.

NOTE: The shorter black wire should already have a terminal attached. If not, crimp the terminal (23-13209-730) on to that wire prior to inserting it into cavity 6 of the SSAM X2 connector.

- 9.5 Squeeze the yellow locking tab back into the connector to lock it. See **Fig. 30**.

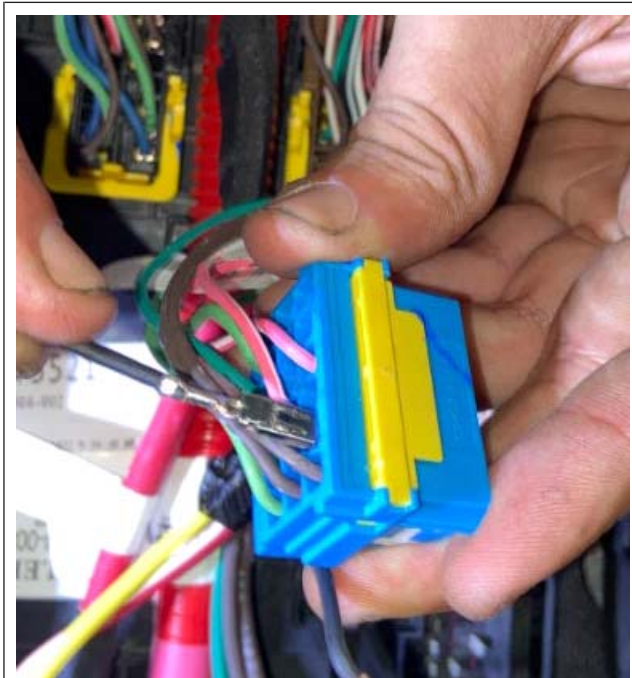

Fig. 29, Inserting the Shorter Black Wire into Cavity 6 of the X2 Connector

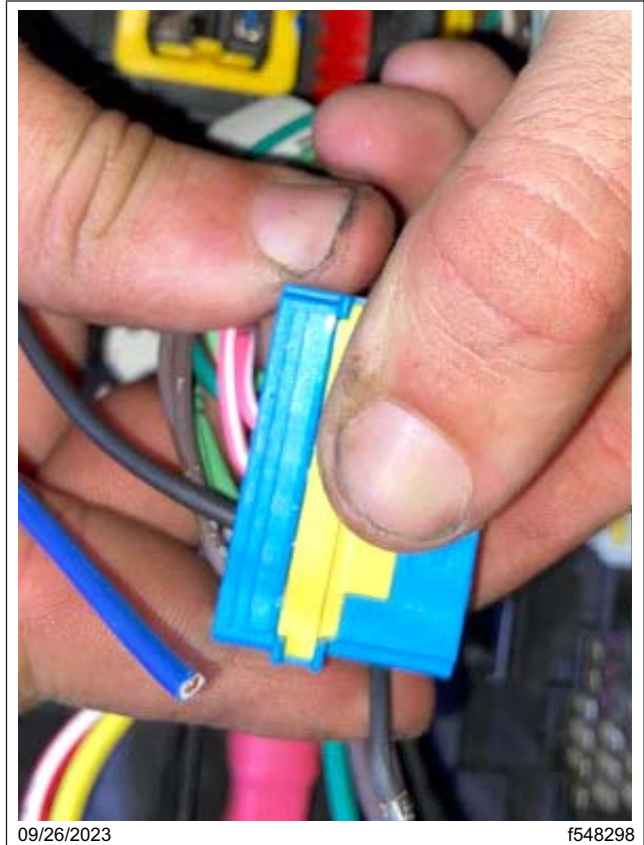

Fig. 30, Engaging the Lock on the SSAM X2 Connector

November 2023
SF678 A
(Revised December 2023)

- 9.6 Plug the X2 connector back into the SSAM. See [Fig. 31](#).



Fig. 31, X2 Connector Plugged into the SSAM

- 9.7 On the wire that was removed from cavity 6 of the SSAM X2 connector in substep 9.4, cut the terminal off and strip the wire. See [Fig. 32](#).



Fig. 32, Wire Removed from Cavity 6 of the SSAM X2 Connector and the Shorter Blue Wire, to be Spliced Together

November 2023
SF678 A
(Revised December 2023)

- 9.8 Splice the wire removed from cavity 6 of the SSAM X2 connector to the shorter blue wire that was routed to the X2 connector in step 7. See [Fig. 33](#).

NOTE: For wire splices, use one of the methods outlined in **Section 54.00, Subjects 100 and 110** of the *Business Class M2 Plus Workshop Manual*.

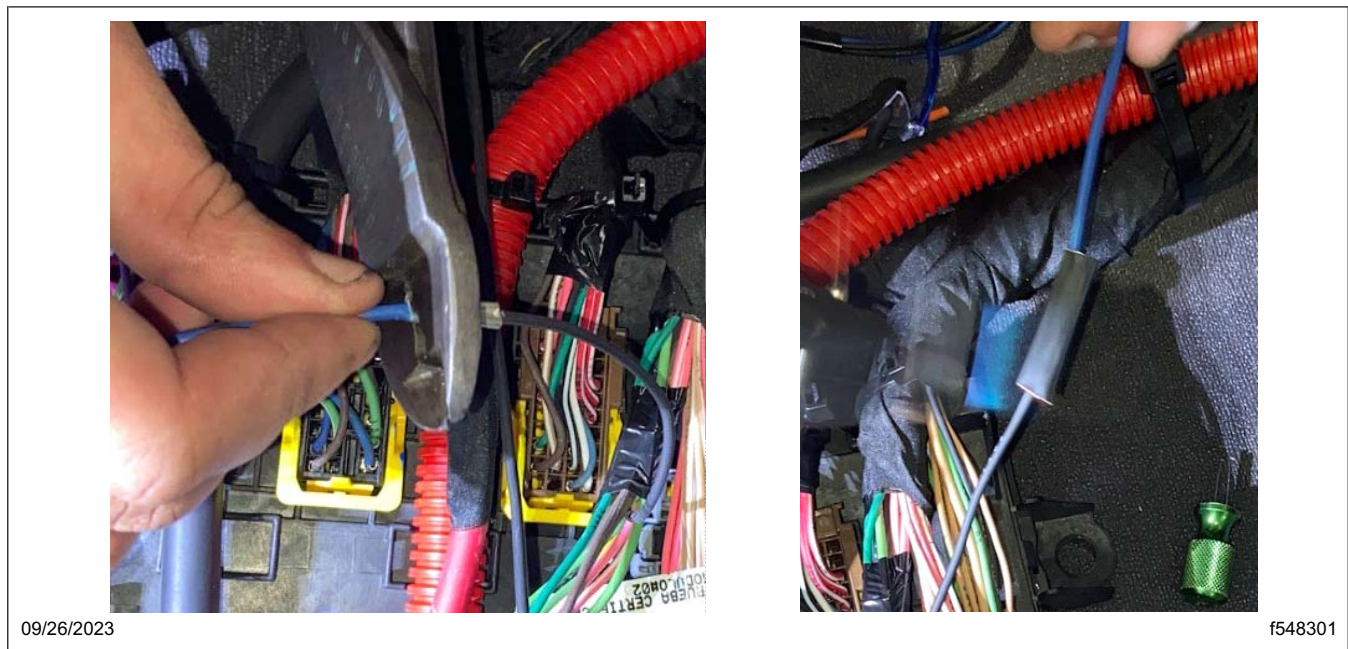

Fig. 33, Splicing the Wire

November 2023
SF678 A
(Revised December 2023)

10. Follow Daimler routing and clipping standards to secure the wires routed to the SSAM, as shown in [Fig. 34](#). Use zip ties to secure the wiring routed from the center dash switch panel to the SSAM, as necessary.

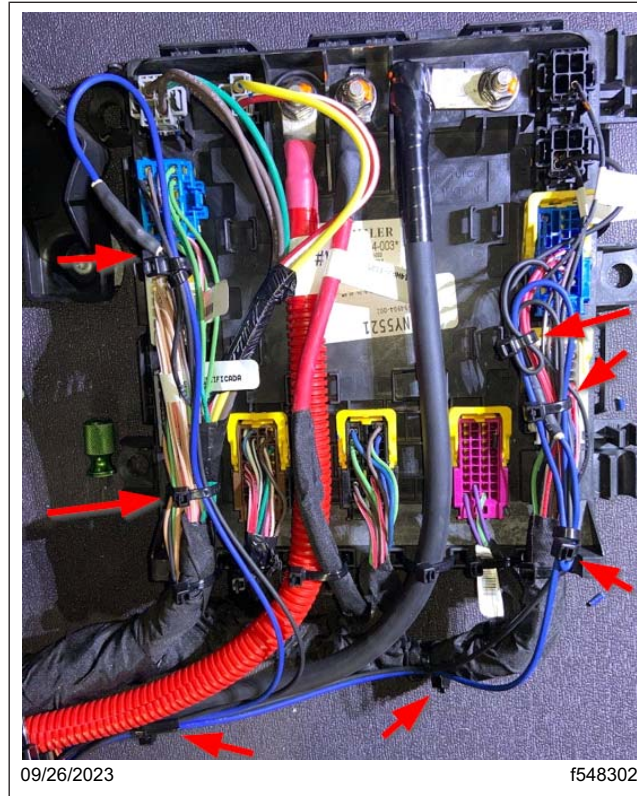

Fig. 34, Securing the Wires Routed to the SSAM

November 2023
SF678 A
(Revised December 2023)

11. Route and terminate the red and brown wires to the XMC2. Locate the end of the red and brown pair of wires. Fold and tape the end of the brown wire. See [Fig. 35](#) and [Fig. 36](#).



Fig. 35, Folding the Brown Wire

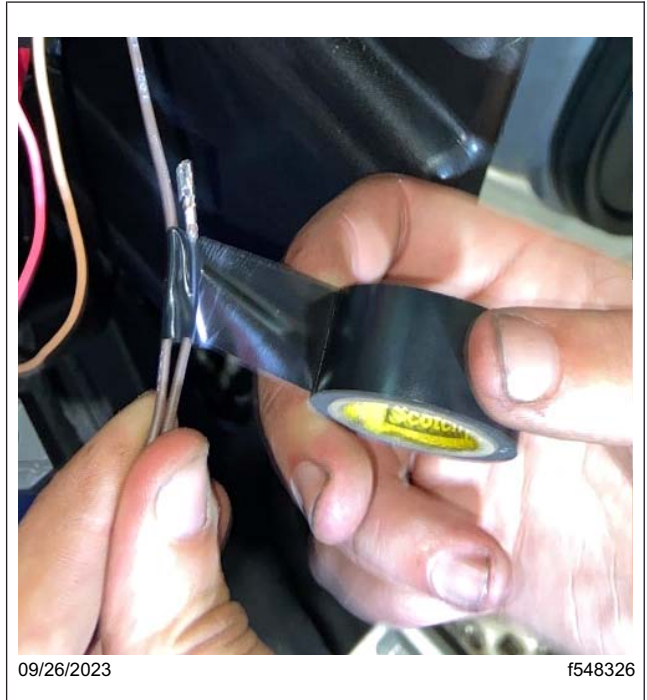
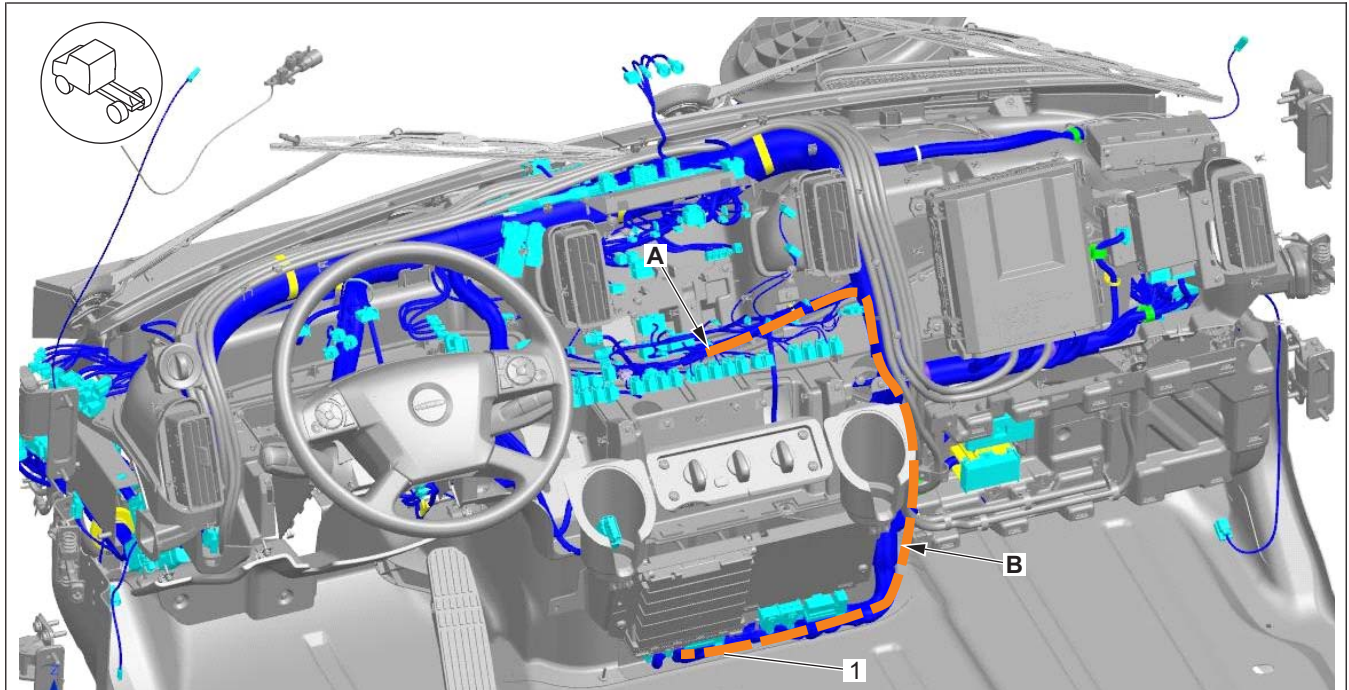

Fig. 36, Taping Up the Brown Wire

November 2023
SF678 A
(Revised December 2023)

12. Route the red and brown wire pair from the center dash switch panel to XMC2, as shown in **Fig. 37** and **Fig. 38**.



11/03/2023

f548422

- A. Start routing the red and brown wire pair to the XMC2 from here. Route the wire in the path along the existing harness as shown.
B. Routing path of the red and brown wire pair.
1. XMC2

Fig. 37, Routing Path of the Red and Brown Wire Pair from Behind the Center Dash Switch Panel to the XMC2

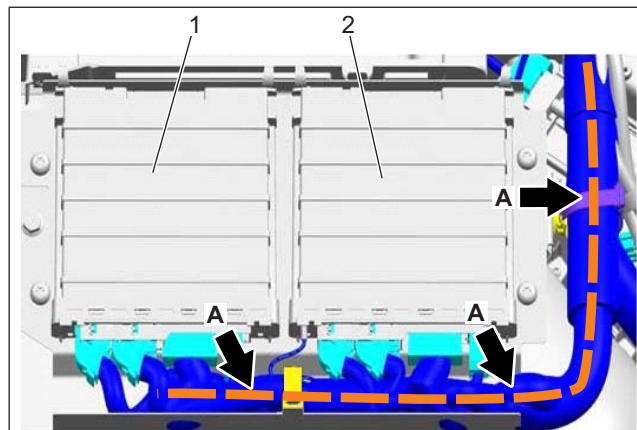

11/03/2023

f548423

- A. Routing path of the red and brown wire pair.
1. XMC2 2. XMC1

Fig. 38, Routing Path of the Red and Brown Wire Pair to the XMC2

November 2023
SF678 A
(Revised December 2023)

13. Use a small flat screwdriver to gently push the lock in so the latch can rotate, and disconnect the X1 connector from XMC2. Rotate the latch all the way to the left-hand side and gently pull the X1 connector out. See [Fig. 39](#), [Fig. 40](#), and [Fig. 41](#).

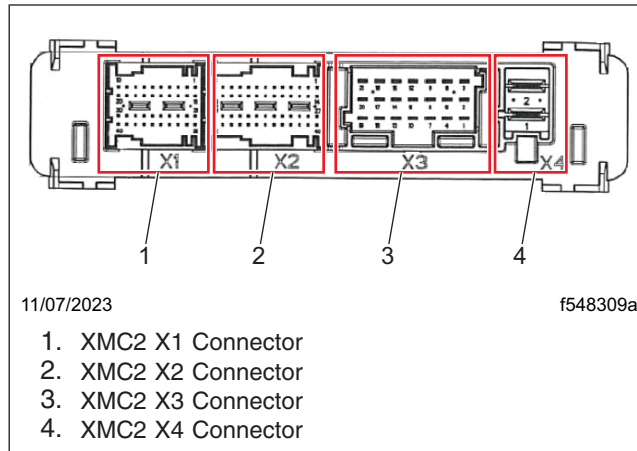

Fig. 39, XMC2 Connector Identification

NOTE: In order to access the X2 connector, X1 connector has to be removed.



Fig. 40, XMC2 X1 Connector Latched

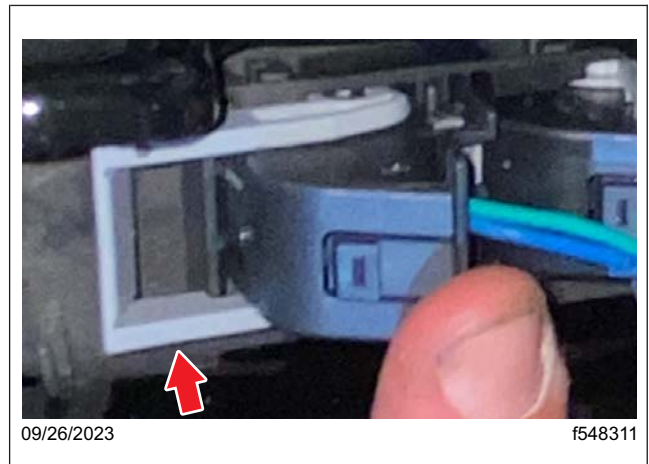

Fig. 41, XMC2 X1 Connector Fully Unlatched

14. Disconnect the X2 connector from XMC2 using the same procedure used to remove the X1 connector. See [Fig. 42](#) and [Fig. 43](#).

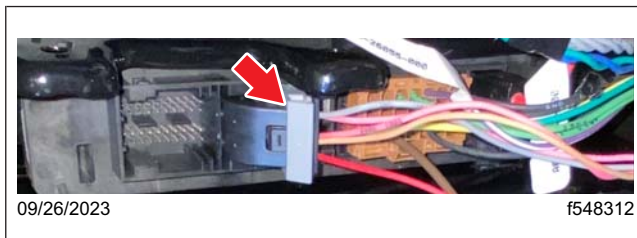

Fig. 42, XMC2 X2 Connector Latched

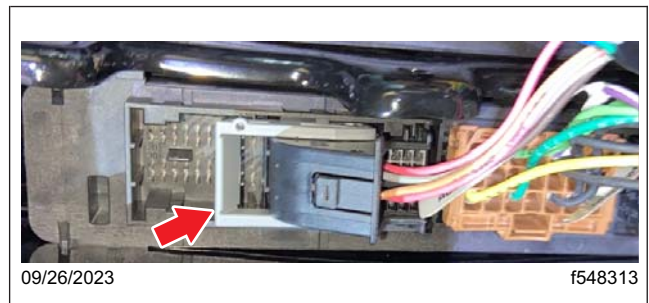

Fig. 43, XMC2 X2 Connector Fully Unlatched

November 2023
SF678 A
(Revised December 2023)

15. Remove the X3 connector from XMC2 by squeezing the locking tab upwards while pulling the connector from the XMC. See [Fig. 39 \(previous page\)](#) and [Fig. 44](#).



Fig. 44, XMC2 X3 Connector Removal

16. Inspect the X3 connector. Check the cavity location of existing brown wire (circuit 102C) in the X3 connector. See [Fig. 45](#).
- If the brown wire (circuit 102C) is in cavity 6, go to the next step to move the brown wire to cavity 16.
 - If the brown wire (circuit 102C) is in cavity 16, go to step 18.

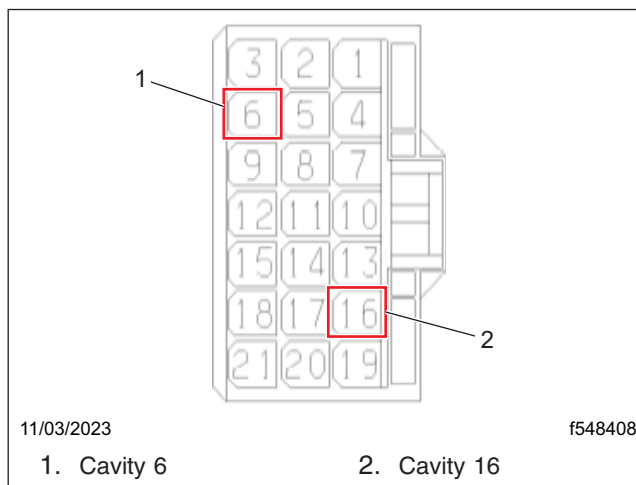

Fig. 45, XMC2 X3 Connector Pin Locations

November 2023
SF678 A
(Revised December 2023)

17. Move the existing brown wire (circuit 102C) from cavity 6 to cavity 16.
 - 17.1 Use a small flat screwdriver to gently pry up the top of the X3 connector, and unlock the connector, as shown in **Fig. 46**.

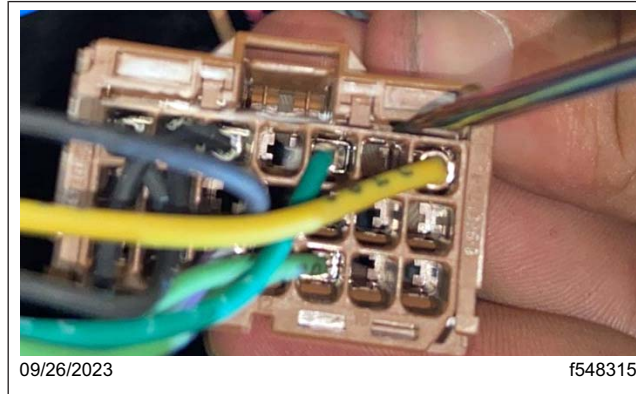

Fig. 46, Unlocking the XMC2 X3 Connector

- 17.2 Remove the brown wire (circuit 102C) from cavity 6 of the X3 connector.
 - 17.3 Insert the brown wire from the harness into the cavity 16 of X3 connector. See **Fig. 47**.
- NOTE: If connecting to the correct XMC (XMC2), then cavity 16 of connector X3 will be empty.

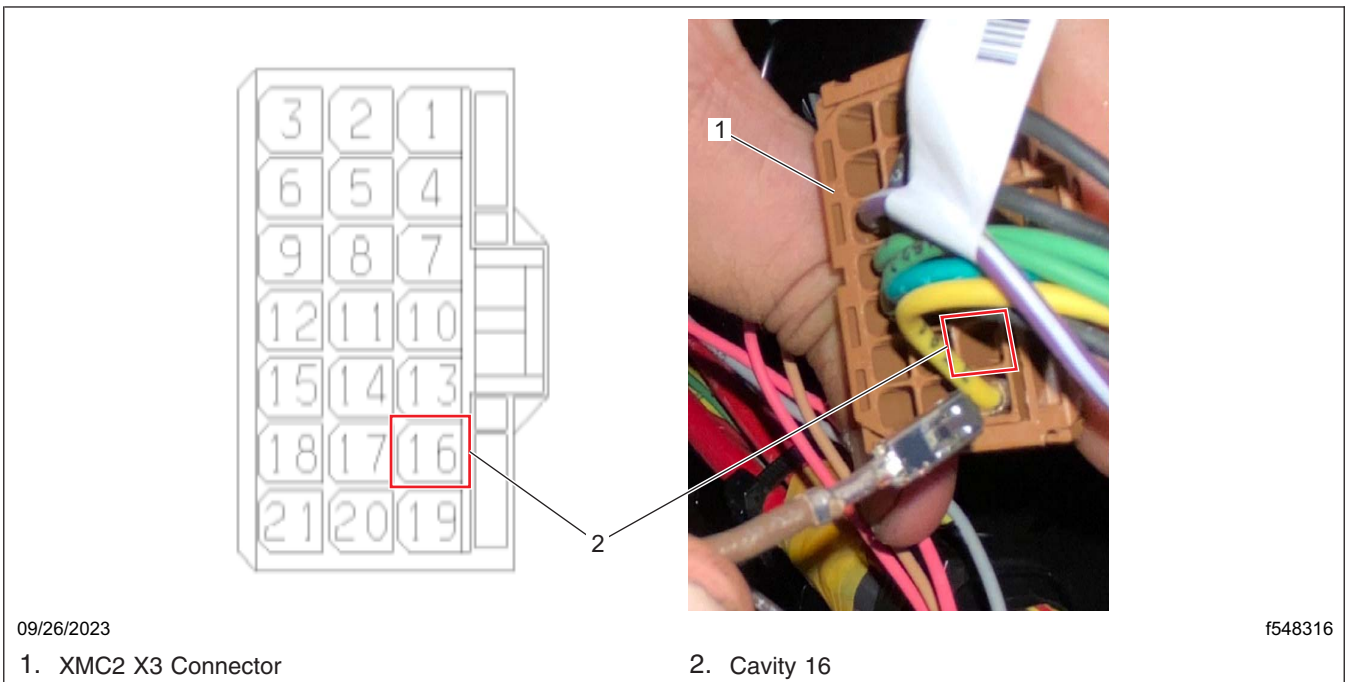

Fig. 47, Inserting the Brown Wire into Cavity 16

November 2023
SF678 A
(Revised December 2023)

- 17.4 Squeeze the top and bottom of the XMC2 X3 connector to lock it. Reconnect the X3 connector to XMC2. See [Fig. 48](#).

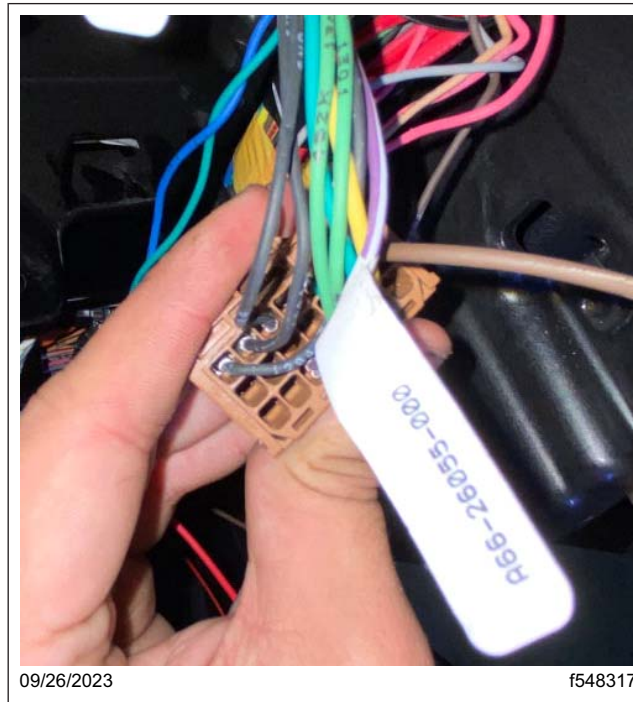

Fig. 48, Engaging the Lock on the XMC2 X3 Connector

18. Orient the XMC2 X2 connector as shown in [Fig. 49](#). The modular X2 connector has two terminal banks, one gray (pins 1–26) and one black (pins 27–52). Note the locking tab location for the black terminal bank (pins 1–26). The black terminal bank has to be removed for the steps that follow.

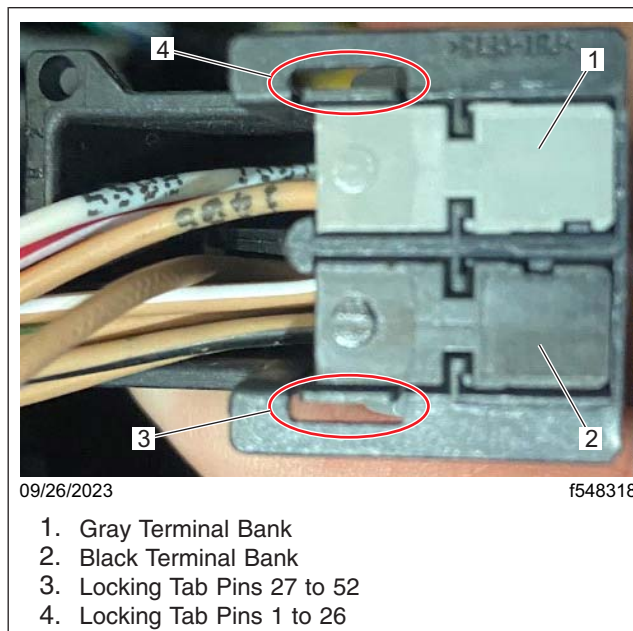

Fig. 49, XMC2 X2 Connector Terminal Bank and Locking Tab Location

November 2023
SF678 A
(Revised December 2023)

19. Insert a small flat screwdriver in between the locking tab for the black terminal bank and gently pry up on the black terminal bank until it clears the locking tab. See [Fig. 50](#) .

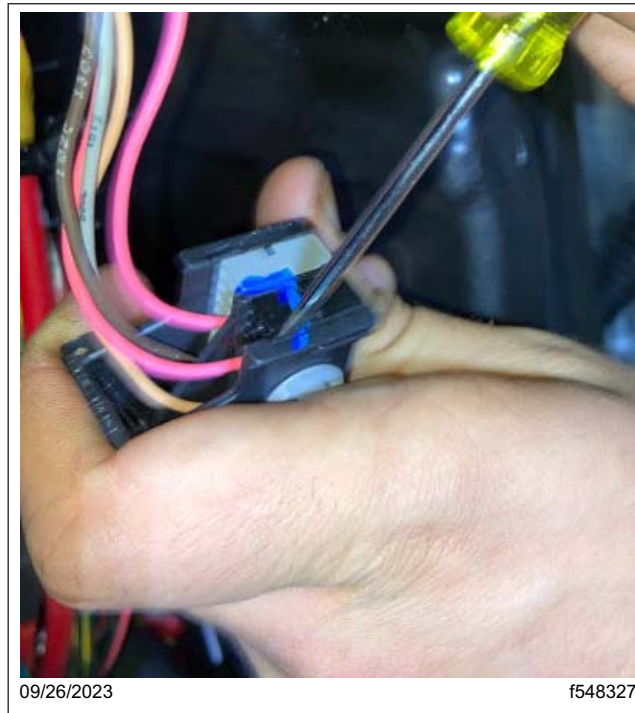

Fig. 50, Releasing the Black Terminal Bank

20. Once the black terminal bank has cleared the locking tab, use the screwdriver on the opposite end and push the rest of the way out of the X2 connector. See [Fig. 51](#) .

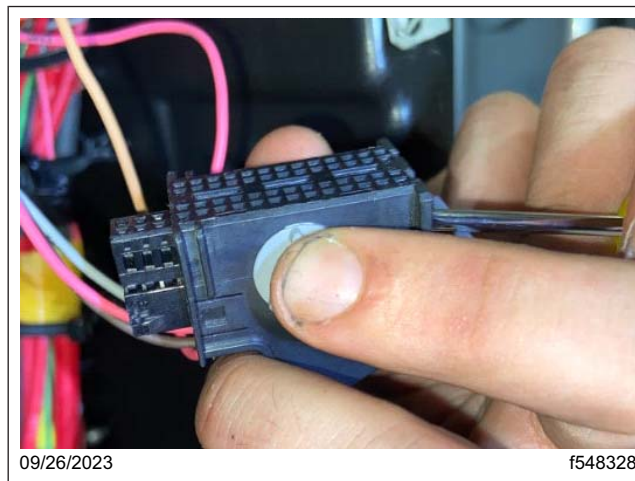

Fig. 51, Pushing Out the Black Terminal Bank

November 2023
SF678 A
(Revised December 2023)

21. Insert the red wire from the harness into cavity 34 of the black terminal bank. See [Fig. 52](#).

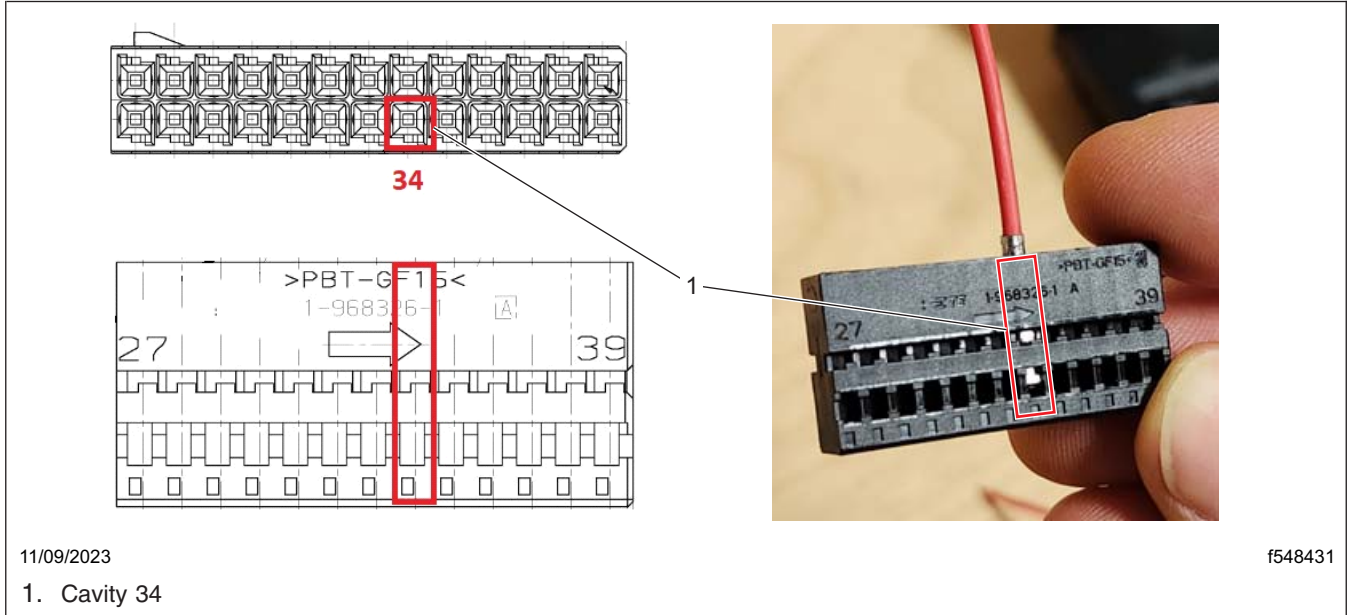

Fig. 52, Inserting the Red Wire into Cavity 34

22. Insert the black terminal bank back into the XMC2 X2 connector, as shown in [Fig. 53](#).

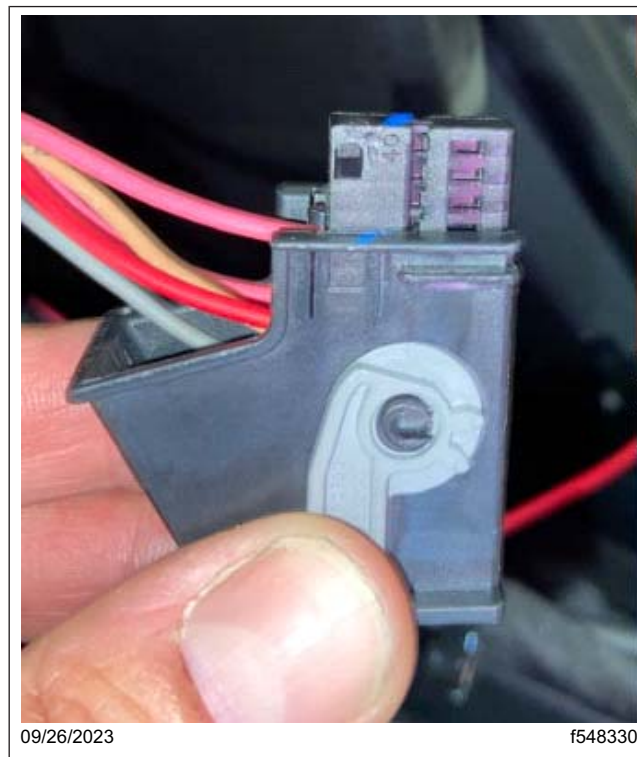

Fig. 53, Inserting the Black Terminal Bank into the XMC2 X2 Connector

November 2023
SF678 A
(Revised December 2023)

23. Connect the X3, X2, and X1 connectors to the XMC2.
24. Secure the red and brown wires routed to XMC2 to the existing dash harness using zip ties as needed. Follow Daimler routing and clipping standards.
25. Follow the substeps to route the orange (or pink) wire to the internal VPDM, and terminate the wire in the J4 VPDM connector.

NOTE: The wire that gets routed in these substeps may be orange or pink. The wire in question will originate from the 6-pin connector in the harness and has a terminal on the other end.

- 25.1 Route the orange (or pink) wire from behind the center dash switch panel to the VPDM connector J4 in the path shown in **Fig. 54**, **Fig. 55**, and **Fig. 56**.

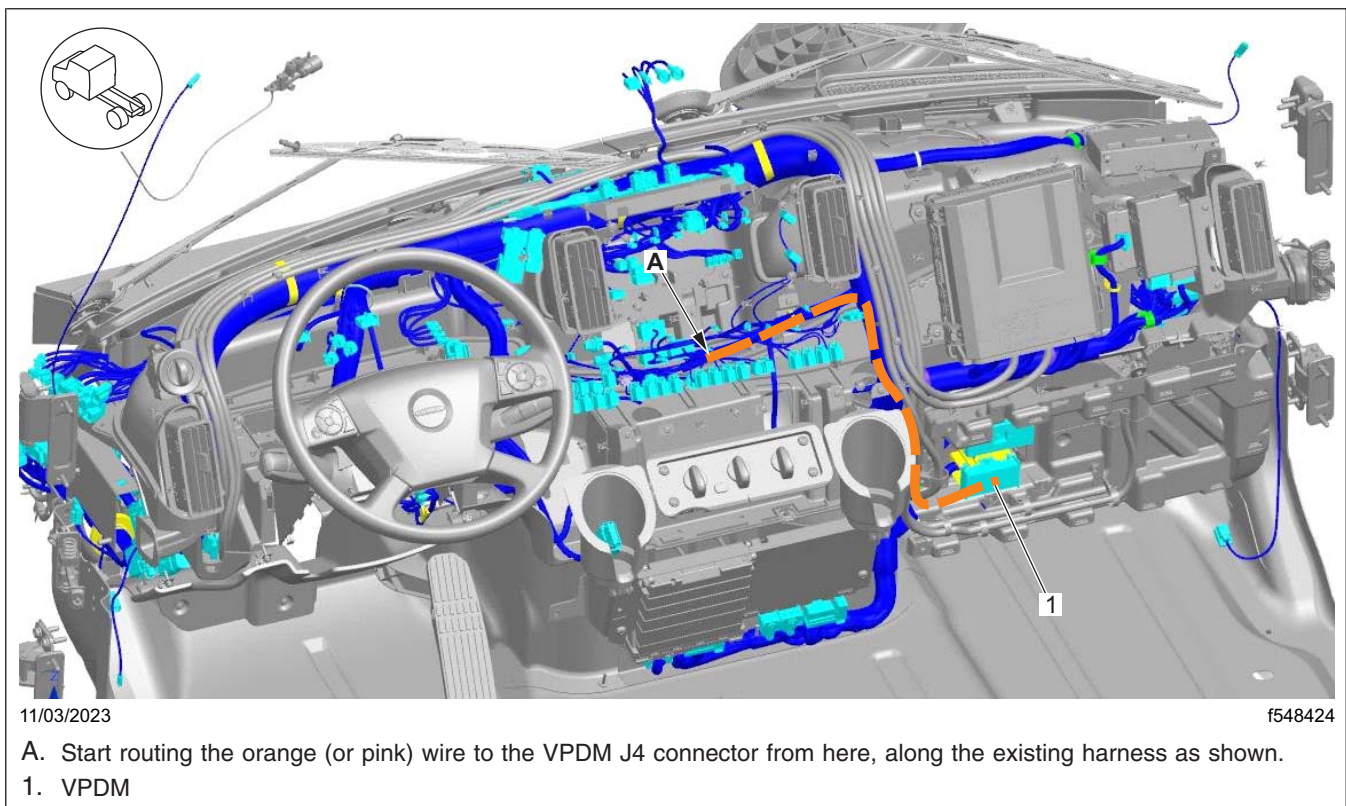

Fig. 54, Routing Path of the Orange (or Pink) Wire from Behind the Center Dash Switch Panel to the VPDM J4 Connector

November 2023
SF678 A
(Revised December 2023)

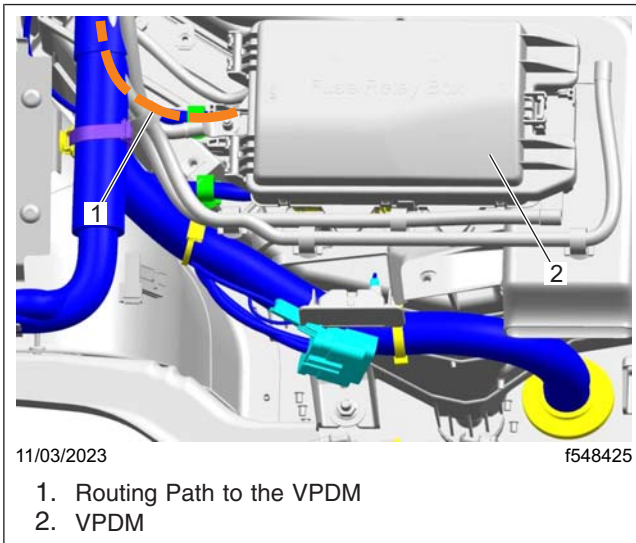

Fig. 55, Routing Path of the Orange (or Pink) Wire in the VPDM Area

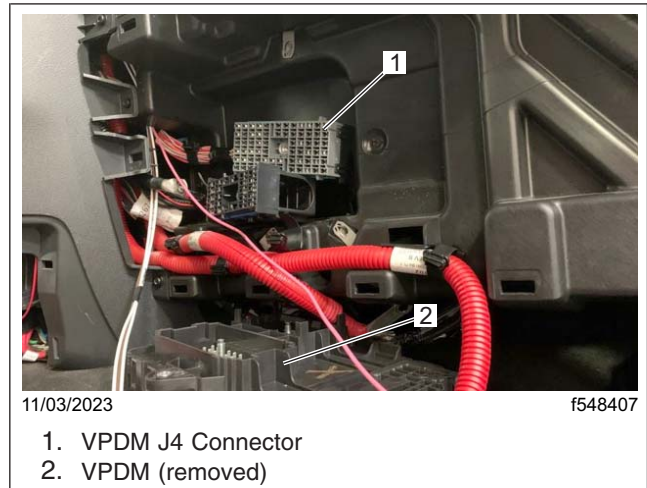

Fig. 56, Location of the VPDM J4 Connector, Where the Orange (or Pink) Wire Terminates

- 25.2 Secure the orange (or pink) wire, routed to the VPDM in the previous substep, to the main harness with zip ties as needed.
- 25.3 Remove the backshell from the J4 VPDM connector.
- 25.4 Remove the locks from the VPDM J4 connector, as shown in [Fig. 57](#).

NOTE: If the cavity B11 (Fuse F6 IGN – Expansion fuse 8) already has a wire installed, use the alternate pin locations listed in [Table 3](#).

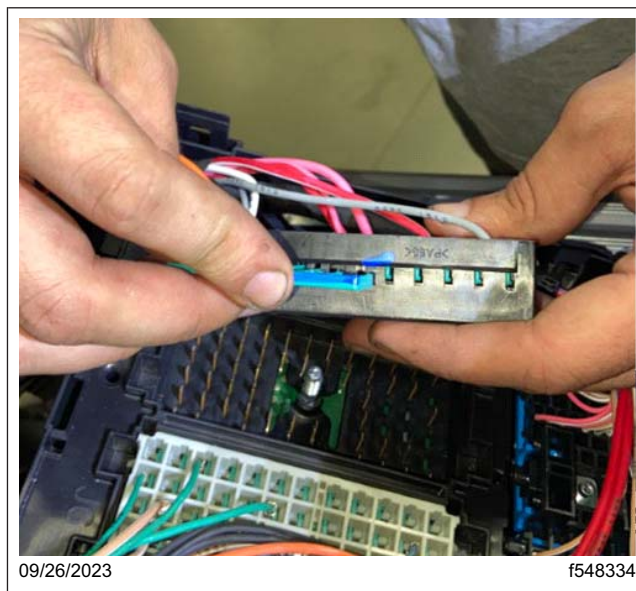

Fig. 57, Removing the Lock from the VPDM J7 Connector

Pin Locations	Fuse Positions
J4/D12	Fuse F11 – Expansion Fuse 15 IGN
J4/F9	Fuse F20 – Expansion Fuse 12 IGN
J4/A11	Fuse F3 – Expansion Fuse 1 IGN

Table 3, Alternate Pin Locations and Fuse Positions

November 2023
SF678 A
(Revised December 2023)

25.5 Insert the orange (or pink) wire into cavity B11 of the VPDM J4 connector. See [Fig. 58](#).

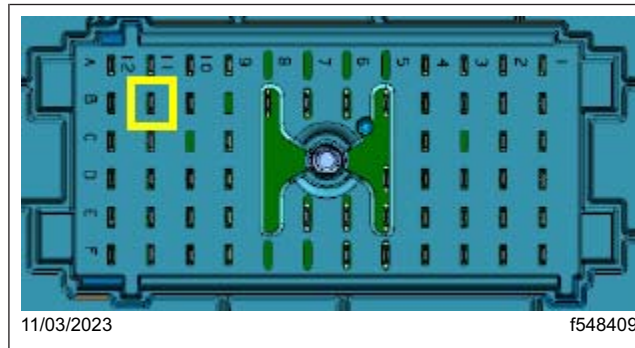

Fig. 58, Inserting the Orange (or Pink) Wire into Cavity B11 of the VPDM J4 Connector

25.6 Install the locks on the J4 connector removed in substep 25.4.

25.7 Install the backshell on the J4 connector.

25.8 Install the VPDM. For instructions, see **Section 54.06, Subject 100** of the *Business Class M2 Plus Workshop Manual*.

25.9 Install the 5A fuse (23-12537-005) in the VPDM fuse position F6. See [Fig. 59](#).

NOTE: If the orange (or pink) wire is installed in one of the alternative pin locations other than B11, install the fuse in the appropriate alternate location listed in [Table 3 \(previous page\)](#).

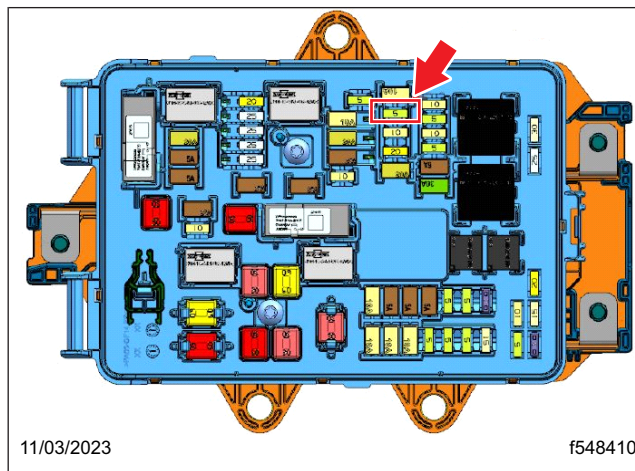

Fig. 59, Installing the 5A Fuse in VPDM Fuse Position F6

November 2023
SF678 A
(Revised December 2023)

26. Follow the substeps to route the two white wires and the brown wire from behind the center dash switch panel to the firewall grommet on the passenger side, under the VPDM.

NOTE: The brown wire will not be used. The end of it can be folded over and taped to the two white wires, once routed.

- 26.1 Route the two white wires and the single brown wire from behind the center dash switch panel to the passenger side firewall pass-through grommet along the existing harness, as shown in **Fig. 60** and **Fig. 61**.

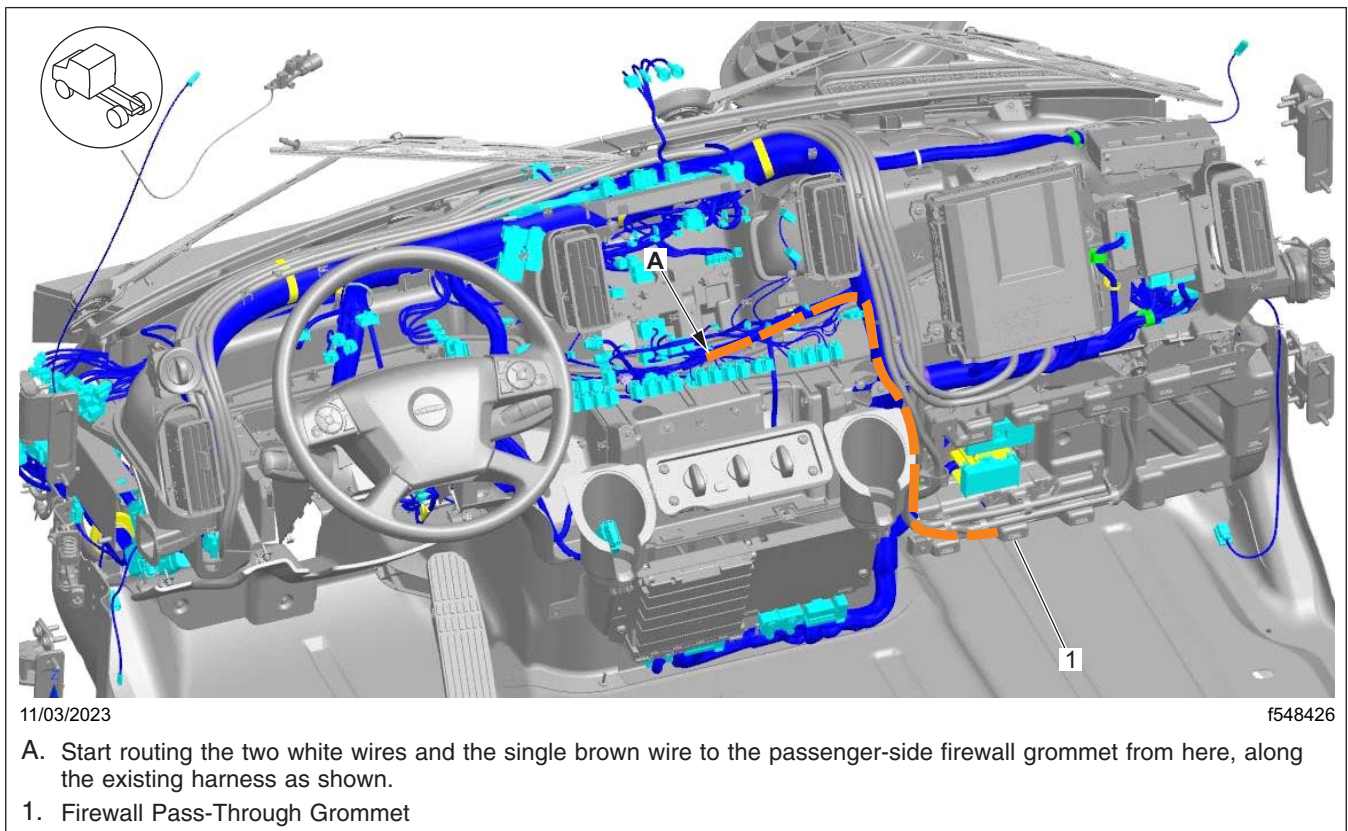

Fig. 60, Routing Path of the Two White Wires and Single Brown Wire from Behind the Center Dash Switch Panel to the Passenger-Side Firewall Pass-Through Grommet

November 2023
SF678 A
(Revised December 2023)

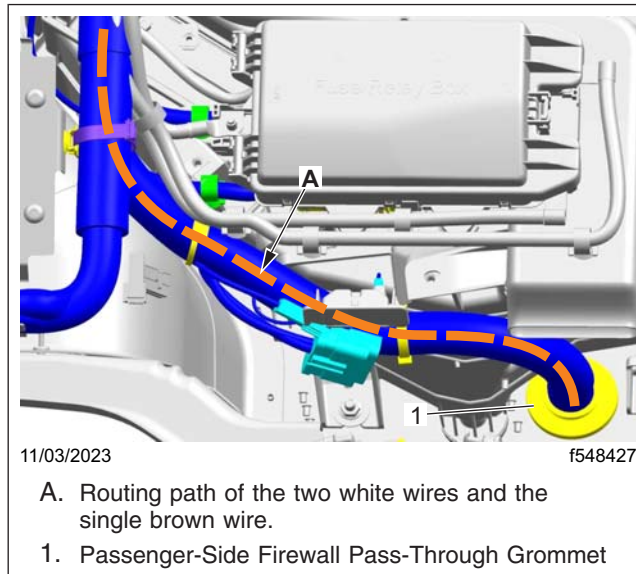

Fig. 61, Routing Path of the Two White Wires and Single Brown Wire Near the Passenger-Side Firewall Pass-Through Grommet

26.2 Remove the tape from the firewall pass-through grommet as needed, and pass the two white wires and the single brown wire through the grommet to the engine side of the firewall.

NOTE: It may be helpful to first pass a large zip tie through the grommet from the engine side, and tape the three wires to the zip tie, then pass the three wires through the grommet by pulling on the zip tie from the engine compartment side.

NOTE: The three wires that are passed through the grommet have terminals on the ends. These terminals will not be used and can be cut off. **Do not** cut off the labels 'BH50' and 'BH38' near the terminals. These labels are needed to correctly splice these wires to harness (TSU CT44FRT034) in a later step.

26.3 Tape the grommet again, as needed.

27. Install the plow light switch.

27.1 Remove the MSF secondary module, that contains the plow light switch, from the dash. For instructions, see **Section 54.12, Subject 110** of the *Business Class M2 Plus Workshop Manual*.

27.2 Remove the existing plow light switch from the MSF secondary module, and discard it.

27.3 Install the new plow light switch (A66-14104-040) in the same position as the switch removed in the previous substep.

November 2023
SF678 A
(Revised December 2023)

27.4 Locate the 6-pin switch connector on the new harness, and plug it in the new switch. See [Fig. 62](#).



Fig. 62, Connector Plugged into the Back of the Plow Light Switch

- 27.5 Install the MSF secondary module with the new plow light switch on the center dash switch panel.
28. If not already done, secure all the wiring that has been routed to the SSAM, XMC2, VPDM, and firewall grommet to the existing dash harness using zip ties as necessary. Bundle any excess wiring behind the center dash switch panel, and secure with zip ties.
 29. On the two white wires that were passed through the firewall grommet in substep 26.2 (TSU CT44FRT033), cut the terminals off. Be careful not to cut the labels 'BH50' and 'BH38' near the terminals.
 30. On the two white wires on harness (TSU CT44FRT034) labeled 'BH50' and 'BH38,' cut the terminals off. Be careful not to cut the labels 'BH50' and 'BH38' near the terminals.

November 2023
SF678 A
(Revised December 2023)

31. Splice the two white wires labeled 'BH50' and 'BH38' on the harness (TSU CT44FRT033) that was passed through the firewall grommet to the two white wires labeled 'BH50' and 'BH38' on the harness (TSU CT44FRT034). Be sure to match labels 'BH50' and 'BH38' while splicing. See [Fig. 63](#).

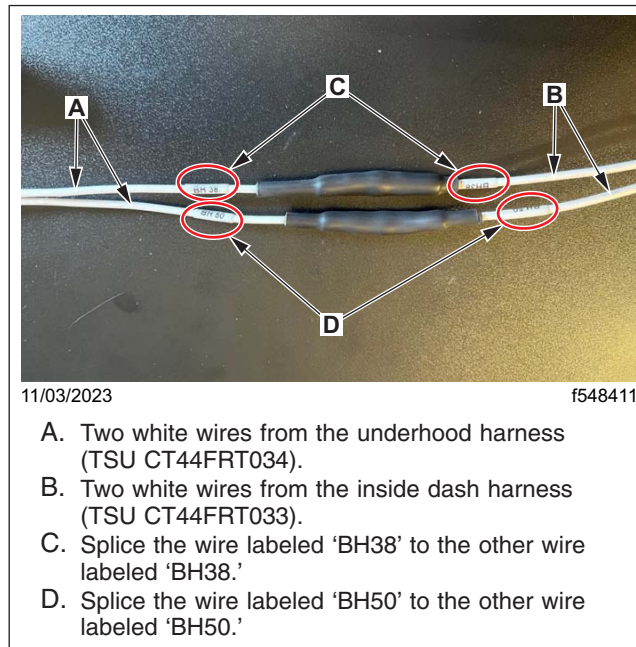

Fig. 63, Splicing the White Wires of the Dash Harness to the Underhood Harness

NOTE: For wire splices, use one of the methods outlined in **Section 54.00, Subjects 100 and 110** of the *Business Class M2 Plus Workshop Manual*.

32. Wrap any remaining exposed wiring that was passed through the firewall grommet with fabric tape.
33. Route the harness (TSU CT44FRT034) towards the front of the vehicle to the existing plow light connector(s) along existing harnesses in the path shown in [Fig. 64](#) and [Fig. 65](#). Secure harness with zip ties as needed.



Fig. 64, Harness Path from the Firewall Grommet Towards the Left-Hand Frame Rail

November 2023
SF678 A
(Revised December 2023)

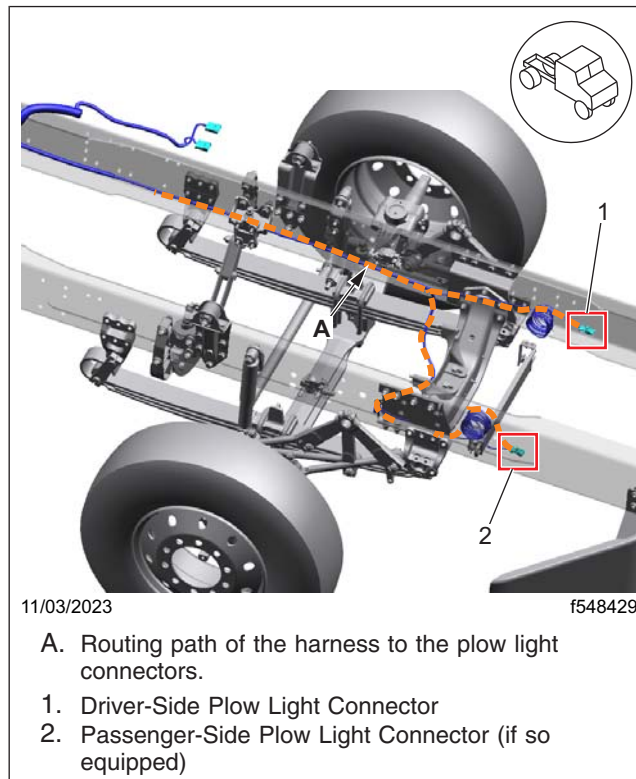

Fig. 65, Harness Path Along the Left-Hand Frame Rail

NOTE: The vehicle configurations may vary. Route the new harness along the existing harnesses or airlines as best as possible.

34. Determine if the vehicle has a single plow light connector or dual plow light connectors.

NOTE: The typical plow light connector locations are shown in [Fig. 65](#). For single plow light configuration, the connector, shown in [Fig. 66](#), is located on the driver's side. For dual plow light configuration, the connectors, shown in [Fig. 74, page 45](#), are located on both the driver's side as well as the passenger's side. Other locations in this general vicinity may be possible.

November 2023
SF678 A
(Revised December 2023)

NOTE: For dual connector interface, skip this step, and go to step 36.

35. For single plow light connector interface:

35.1 Remove the cover and lock from the plow light interface connector. See [Fig. 66](#), [Fig. 67](#), and [Fig. 68](#).



Fig. 66, Single Connector Plow Light Interface



Fig. 67, Single Plow Light Interface Connector with the Cover Removed

November 2023
SF678 A
(Revised December 2023)

35.2 Locate the empty cavity (cavity G) and remove the rubber plug. See [Fig. 69](#).



Fig. 68, Single Plow Light Interface Connector with the Lock Removed

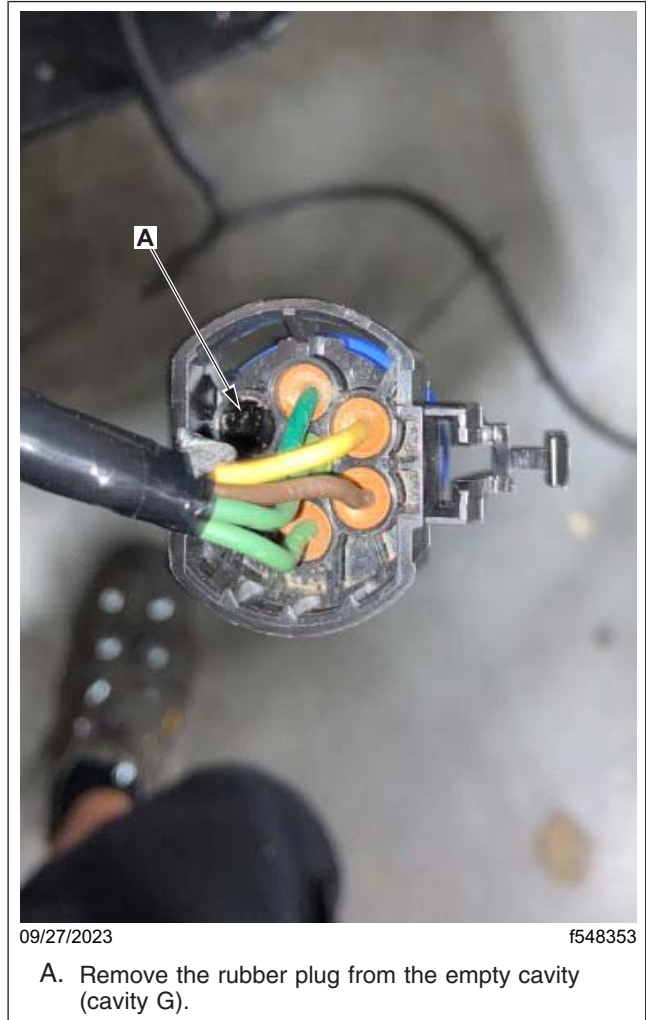

Fig. 69, Single Plow Light Interface Connector with the Plug Removed from the Empty Cavity (cavity G)

November 2023
SF678 A
(Revised December 2023)

- 35.3 Cut a length of white 16-gauge wire approximately 24-inches long. On one end of this short wire, install a terminal (PAC 12110847 L) and seal (PAC 15324984 B). See [Fig. 70](#).

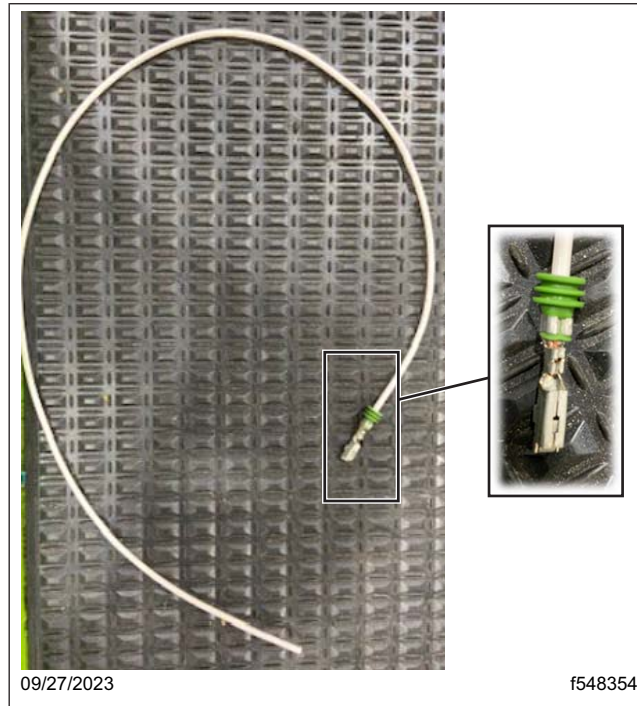

Fig. 70, 24-Inch Length of 16 Gauge Wire with the Terminal and Seal Crimped on One End

November 2023
SF678 A
(Revised December 2023)

- 35.4 Insert the wire into the open cavity (cavity G) of the plow light interface connector, and install the connector lock. See [Fig. 71](#) and [Fig. 72](#).



Fig. 71, Inserting the Wire into the Open Cavity of the Single Plow Light Connector

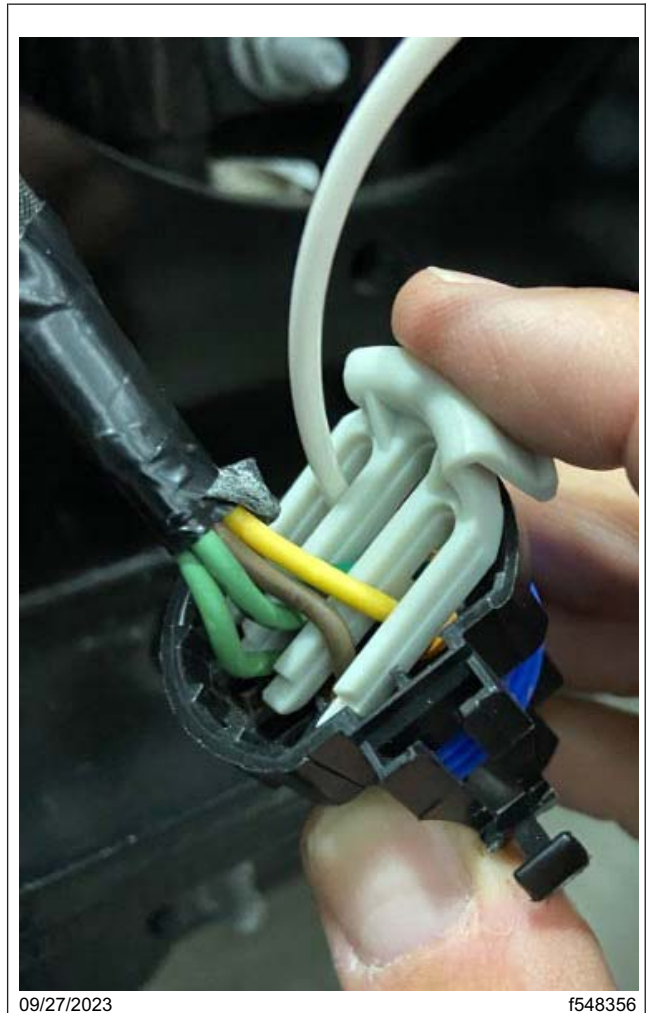

Fig. 72, Installing Lock on Single Plow Light Connector

November 2023
SF678 A
(Revised December 2023)

35.5 Splice the two white wires that were routed from the firewall pass-through grommet to the short wire that was connected to the plow connector in the previous substep. See [Fig. 73](#).

NOTE: Trim the two white wires routed from the firewall pass-through grommet to length as needed. This includes discarding the terminals that were on the end of these two wires.

NOTE: For wire splices, use one of the methods outlined in **Section 54.00, Subjects 100 and 110** of the *Business Class M2 Plus Workshop Manual*.



Fig. 73, Completed Splice

35.6 Wrap any exposed wiring from the plow light connector to the taped portion of the two white wires routed from the firewall pass-through grommet with fabric tape.

35.7 Secure the harness with zip ties as needed.

NOTE: Leave the connector cover off for testing in a later step.

36. For dual plow light connector interface:

36.1 Cut the terminal off the ends of the two white wires that were routed from the firewall to the plow light interface connectors, and install the terminal (23-13213-030) and seal (23-12497-006) on the end of each wire.

36.2 Remove the cover and lock from the each plow light interface connector. See [Fig. 74](#), [Fig. 75](#), and [Fig. 76](#).

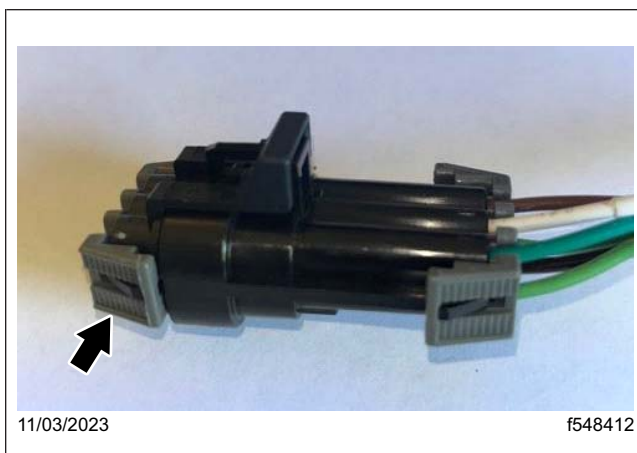

Fig. 74, Plow Light Interface Connector with Cover Installed

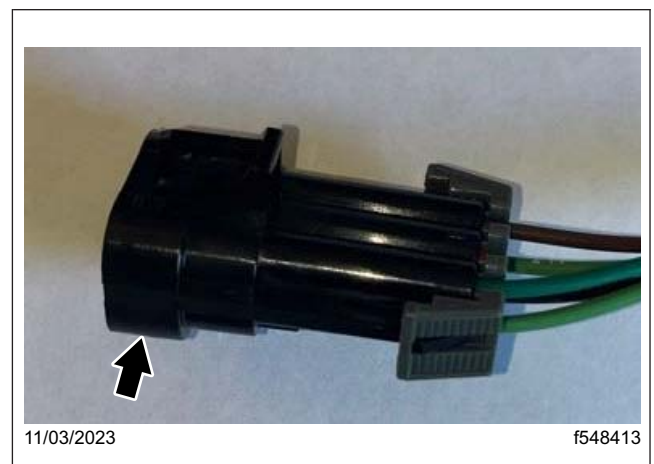

Fig. 75, Plow Light Interface Connector with Cover Removed

November 2023
SF678 A
(Revised December 2023)

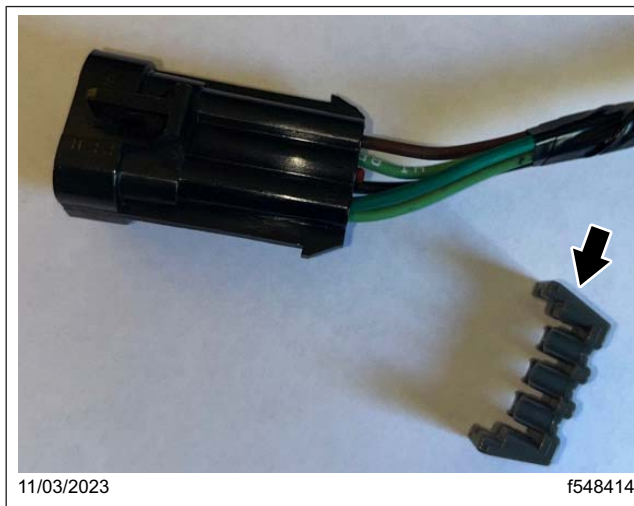

Fig. 76, Plow Light Interface Connector with the Lock Removed

- 36.3 Locate the empty cavity (cavity E), and remove the rubber plug from each of the two plow light interface connectors. See [Fig. 77](#).

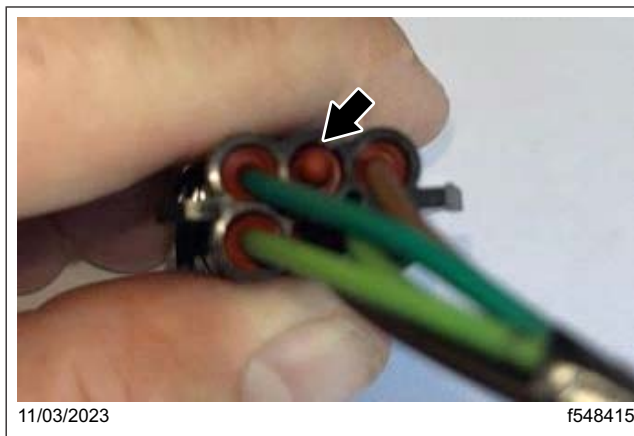

Fig. 77, Plow Light Interface Connector with the Plug to be Removed from the Empty Cavity (cavity E)

November 2023
SF678 A
(Revised December 2023)

- 36.4 Route the two white wires that were routed from the firewall pass-through grommet to each of the two plow light connectors. Make sure the wire marked 'left' goes to the driver-side connector, and the wire marked 'right' goes to the passenger-side connector. The wire to the passenger-side plow light interface connector can follow the harness behind the front engine crossmember, as shown in [Fig. 65, page 40](#) and [Fig. 78](#).

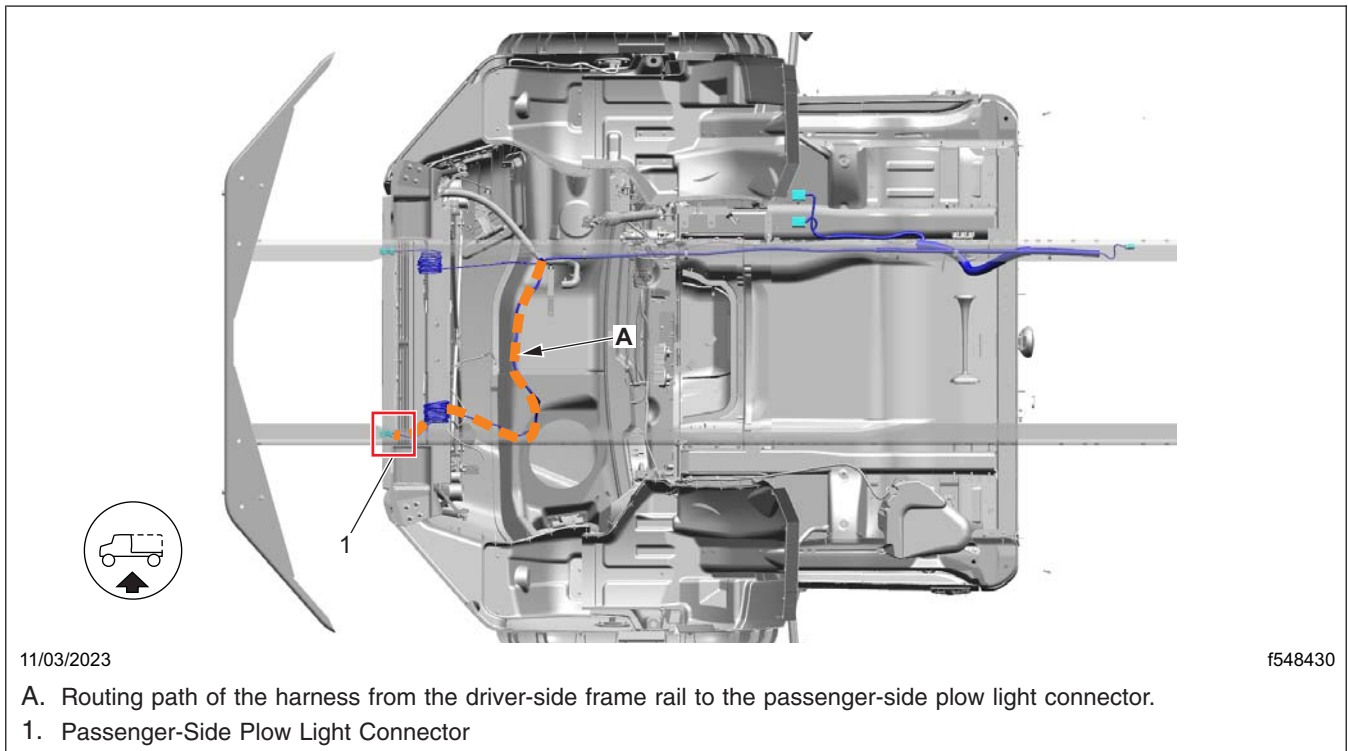

Fig. 78, Routing Path of the Harness to Passenger-Side Plow Light Interface Connector Along the Front Engine Crossmember

NOTE: Depending on the vehicle configuration and plow light connector location, it may be necessary to lengthen the wires as needed.

- 36.5 Insert the wire marked 'left' into the empty cavity (cavity E) of the driver-side plow light connector. Insert the wire marked 'right' in the empty cavity (cavity E) of the passenger-side plow light connector. See [Fig. 79](#).

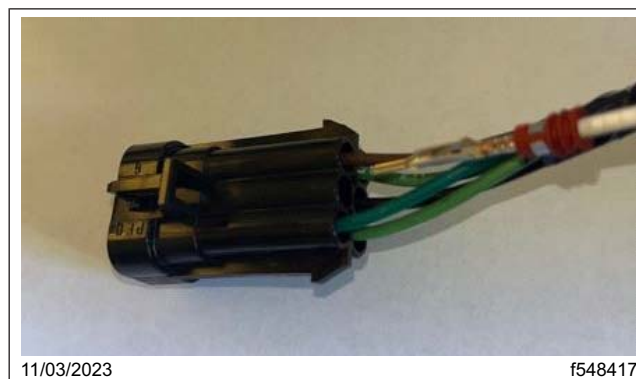

Fig. 79, Inserting the Wire into the Open Cavity E of the Plow Light Connector

November 2023
SF678 A
(Revised December 2023)

36.6 Install the lock on each connector. See [Fig. 80](#).

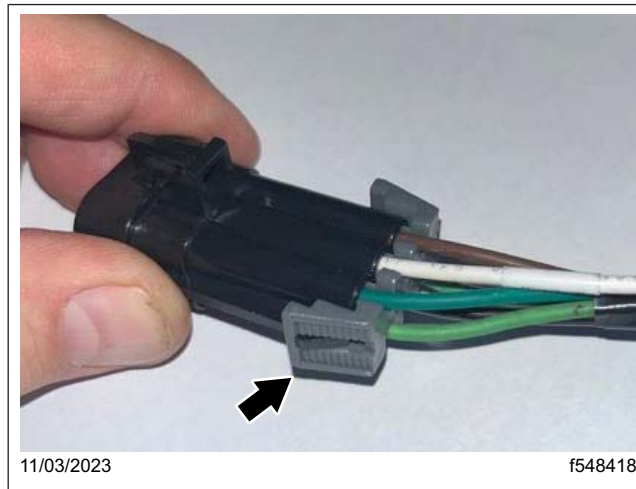

Fig. 80, Installing the Lock on the Plow Light Connector

36.7 Wrap any exposed wiring that was routed to the plow light connectors with fabric tape as needed.

36.8 Secure the wiring with zip ties as needed.

NOTE: Leave the connector covers off for testing in a later step.

37. Connect the battery cables.

38. Follow the substeps to set the parameters in the XMC2 and SSAM. See [Table 4](#).

XMC2 and SSAM Parameter Settings		
Module	Parameter Description	Parameter Part Number
XMC2	PFSC_DFunc0002_mode = AH (fragment under the 'FSC Input Config' Domain)	033 447 07 46 ZGS 001
	FSC Logic Block 26_30	033 447 04 46 ZGS 001
	FSC Parameters OutputPinBlock 1_12	030 447 30 46 ZGS 003
	FSC Parameters OutputPin block 13_18	030 447 53 46 ZGS 002
SSAM	ELC HW Config	033 447 60 58 ZGS 003
	Switch 465 (fragment under the 'MSC MSF Vehicle Config' Domain)	039 457 69 58 ZGS 001
	Switch 69 (fragment under the 'MSC MSF Vehicle Config' Domain)	016 443 67 58 ZGS 001

Table 4, XMC2 and SSAM Parameter Settings

38.1 Connect the vehicle to DiagnosticLink®.

38.2 Turn the ignition key to the 'Run' position.

38.3 Open DiagnosticLink.

IMPORTANT: Make sure that DiagnosticLink is updated to the latest version (8.17 SP1 at the time of publication or newer) before programming the vehicle.

November 2023
SF678 A
(Revised December 2023)

38.4 Go to the 'Program Device' tab, and make sure that the vehicle identification number (VIN) is correct. Select 'Download data from server.' **Fig. 81.**

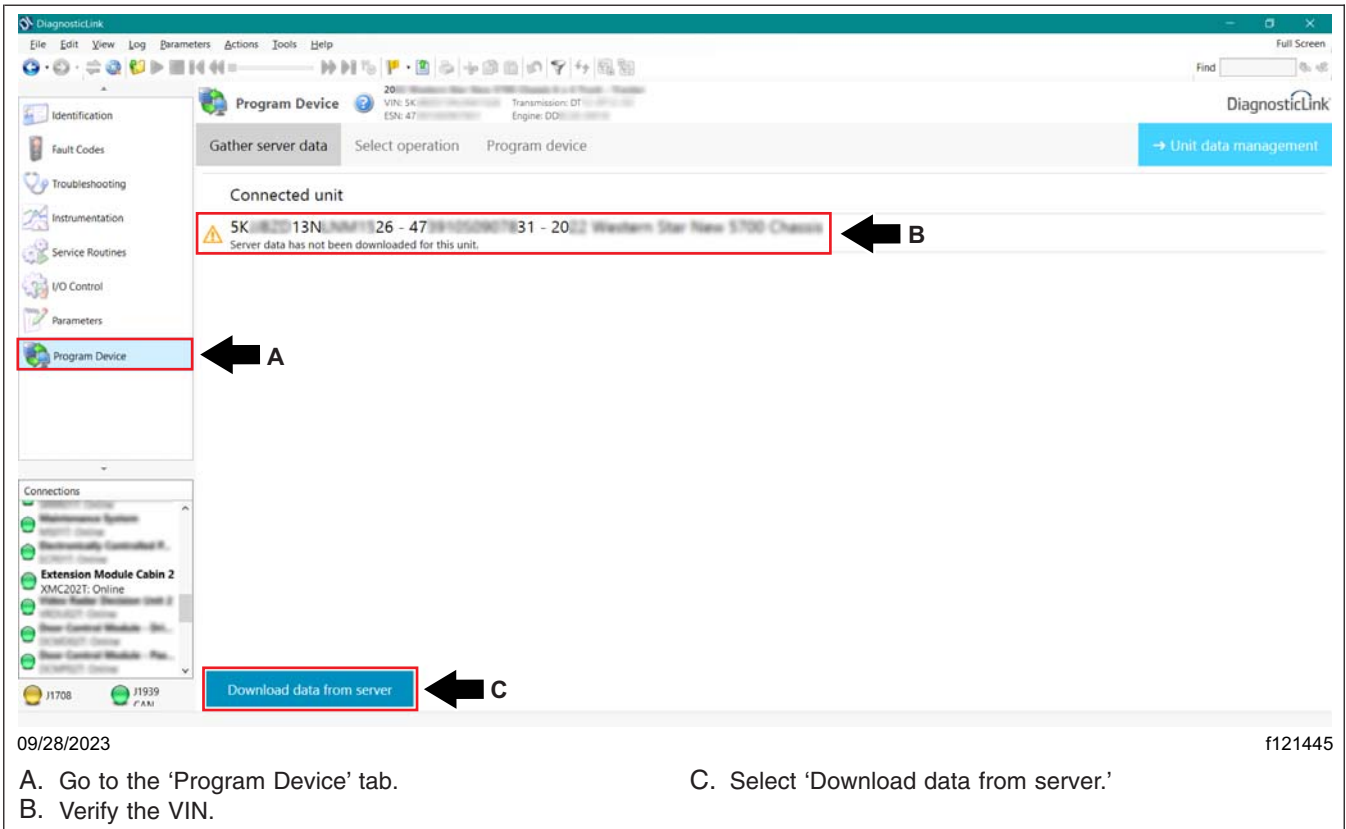

Fig. 81, Downloading Data from the Server

38.5 After the server data download is complete, go to the 'Parameters' tab.

NOTE: Some parameters may already be set to the correct values. Be sure to check each one to be sure.

November 2023
SF678 A
(Revised December 2023)

38.6 Select and expand the 'XMC202T – Extension Module Cabin 2' folder. See [Fig. 82](#).

09/28/2023 f121446

A. Go to the 'Parameters' tab.
B. Select and expand the 'XMC202T – Extension Module Cabin 2' folder.

Fig. 82, Selecting the 'XMC202T – Extension Module Cabin 2' Folder

38.7 Select and expand the 'FSC Input Config' sub-folder, and select the 'PFSC_DFnc0002_mode' parameter. Set the parameter value to 'A0334470746-001 PFSC_DFnc0002_mode = AH.' See [Fig. 83](#).

11/07/2023 f121459

A. Select and expand the 'FSC Input Config' folder.
B. Select the 'PFSC_DFnc0002_mode' parameter.
C. Set the parameter value to 'A0334470746-001 PFSC_DFnc0002_mode = AH.'

Fig. 83, Setting the 'PFSC_DFnc0002_Mode' Parameter Value

November 2023
SF678 A
(Revised December 2023)

38.8 Select the 'FSC Logic Block 26_30' sub-folder, and set the parameter value to 'A0334470446-001 FSC Logic Block 26_30 M2 Snow Plow Lights.' See **Fig. 84**.

11/03/2023 f121460

A. Select the 'FSC Logic Block 26_30' sub-folder.
B. Set the parameter value to 'A0334470446-001 FSC Logic Block 26_30 M2 Snow Plow Lights.'

Fig. 84, Setting the 'FSC Logic 26_30' Parameter Value

38.9 Select the 'FSC Parameters OutputPinBlock 1_12' sub-folder, and set the parameter value to 'A0304473046-003 OutputPinBlock 1_12 81Z-006 43N SP Trn Sig Mrkr Util Lgt Fix.' See **Fig. 85**.

11/03/2023 f121461

A. Select the 'FSC Parameters OutputPinBlock 1_12' sub-folder.
B. Set the parameter value to 'A0304473046-003 OutputPinBlock 1_12 81Z-006 43N SP Trn Sig Mrkr Util Lgt Fix.'

Fig. 85, Setting the 'FSC Parameters OutputPinBlock 1_12' Parameter Value

November 2023
SF678 A
(Revised December 2023)

38.10 Select the 'FSC Parameters OutputPinBlock 13_18' sub-folder, and set the parameter value to 'A0304475346-002 OutputPinBlock 13_18 81Z-006 43N SP Trn Sig Mrkr Util Lgt Fix.' See [Fig. 86](#).

11/03/2023 f121462

A. Select the 'FSC Parameters OutputPinBlock 13_18' sub-folder.
B. Set the parameter value to 'A0304475346-002 OutputPinBlock 13_18 81Z-006 43N SP Trn Sig Mrkr Util Lgt Fix.'

Fig. 86, Setting the 'FSC Parameters OutputPinBlock 13_18' Parameter Value

38.11 Select and expand the 'SSAM02T - Single SAM' folder. See [Fig. 87](#).

03/16/2023 f121360

A. Ensure the 'Parameters' tab is selected.
B. Select and expand the 'SSAM02T - Single SAM' folder.

Fig. 87, Selecting the 'SSAM02T - Single SAM' Folder

November 2023
SF678 A
(Revised December 2023)

38.12 Select the 'ELC – HW Config' sub-folder, and set the parameter value to 'A0334476058-003 ELC HW_Config – LED 003.' See [Fig. 88](#).

09/28/2023 f121453

A. Select the 'ELC – HW Config' sub-folder.
B. Set the parameter value to 'A0334476058-003 ELC HW_Config – LED 003.'

Fig. 88, Setting the 'ELC - HW Config' Parameter Value

38.13 Select and expand the 'MSC MSF Vehicle Config' sub-folder, then select the 'Switch_069' parameter, and set the parameter value to 'A0164436758-001 Switch_069 = Switch Not Present.' See [Fig. 89](#).

09/28/2023 f121454

A. Select and expand the 'MSC MSF Vehicle Config' sub-folder.
B. Select the 'Switch_069' parameter.
C. Set the parameter value to 'A0164436758-001 Switch_069 = Switch Not Present.'

Fig. 89, Setting the 'Switch_069' Parameter Value

38.14 Select the 'Switch_465' parameter. Set the parameter value to 'A0394576958-001 Switch 465 = Switch Present.' See [Fig. 90](#).

09/28/2023 f121455

A. Select the 'Switch_465' parameter.
B. Set the parameter value to 'A0394576958-001 Switch 465 = Switch Present.'

Fig. 90, Setting the 'Switch_465' Parameter Value

November 2023
SF678 A
(Revised December 2023)

38.15 Select the 'Send' button to write the parameter changes to the vehicle. A window will open asking to confirm the parameter changes. Select 'OK.' See [Fig. 91](#).

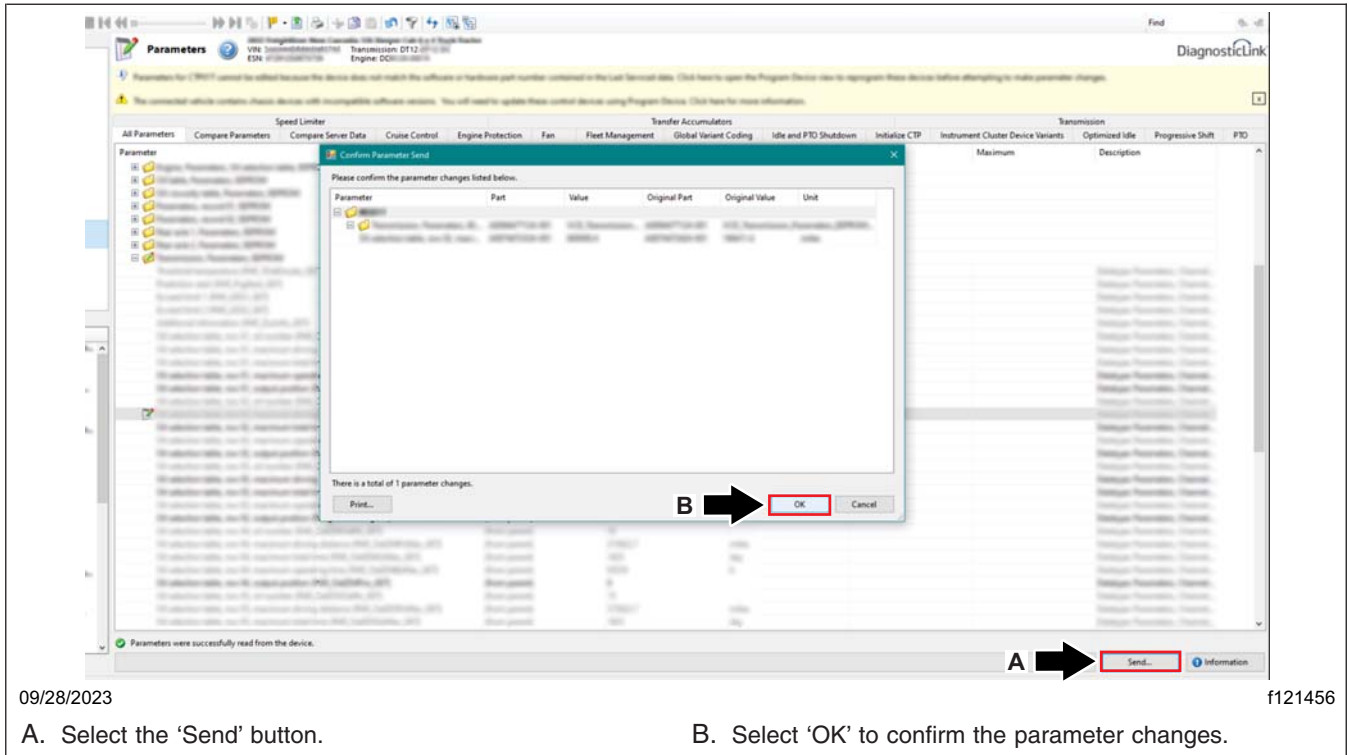

Fig. 91, Writing the Parameter Changes to the Vehicle

November 2023
SF678 A
(Revised December 2023)

38.17 The information corresponding to the VIN should appear under the 'Unit data for upload.' Select 'Connect to server' to upload the new parameters. See **Fig. 93**.

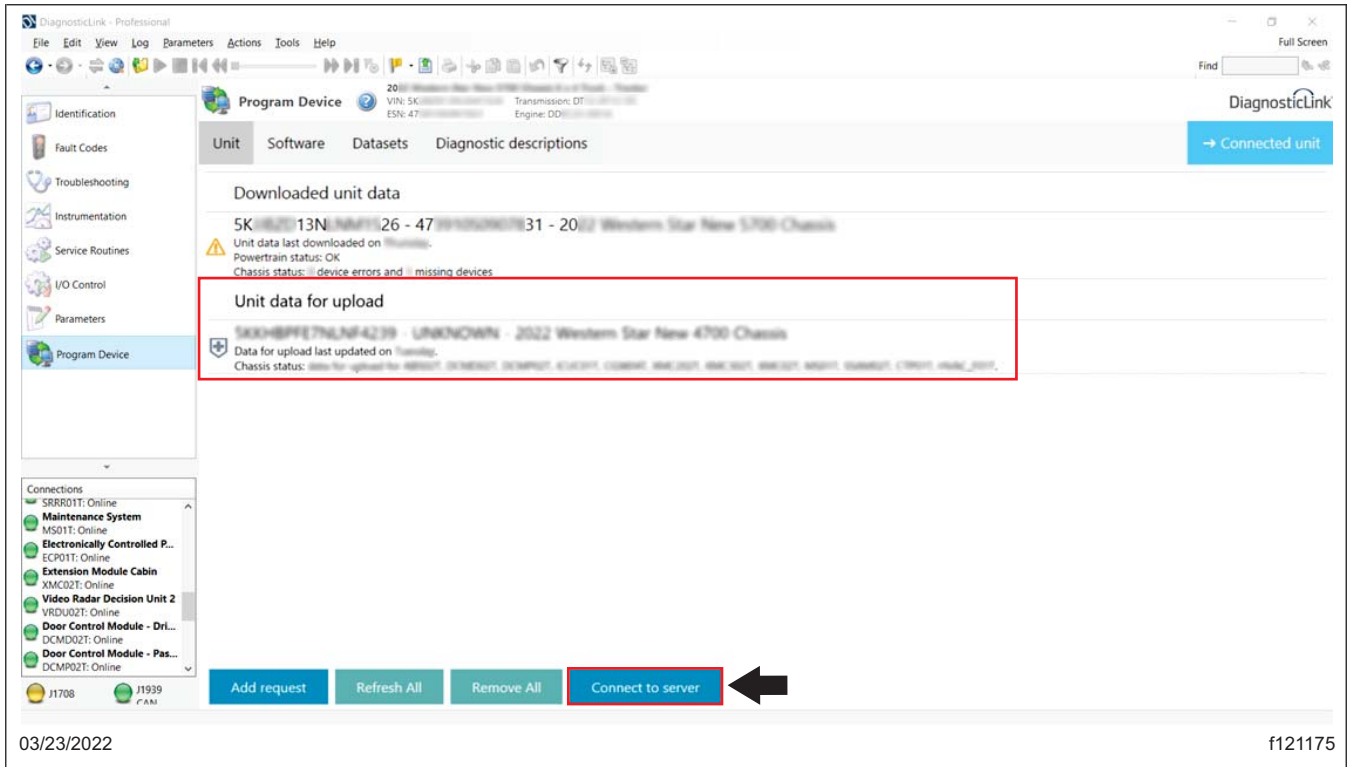

Fig. 93, Uploading the New Parameters

38.18 Once the parameter updates are uploaded to the server, disconnect the vehicle from DiagnosticLink.

38.19 Turn the ignition key to the OFF position.

November 2023
SF678 A
(Revised December 2023)

39. Follow the substeps to verify the plow light switch function.

39.1 Install test jumper(s) in the plow light interface connector(s) as follows:

- **For single connector plow light interface** → Install a test jumper in the plow light interface connector between pin G (white wire added) and pin B (ground). See [Fig. 94](#) and [Fig. 98, page 59](#).
- **For dual connector plow light interface** → On each of the two plow light interface connectors, install a test jumper between pin E (white wire added) and pin B (ground). See [Fig. 95](#) and [Fig. 99, page 59](#).

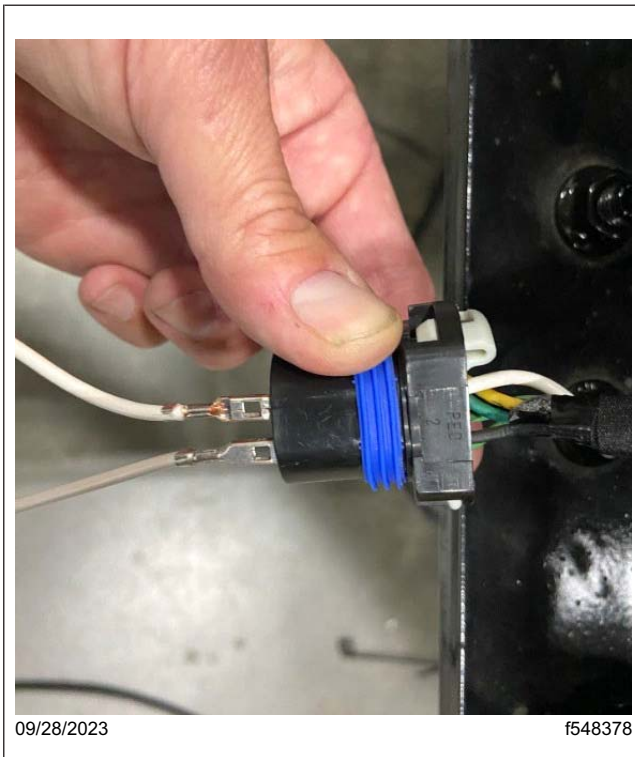

Fig. 94, Testing the Jumper Wire Installed in the Single Connector Plow Light Interface

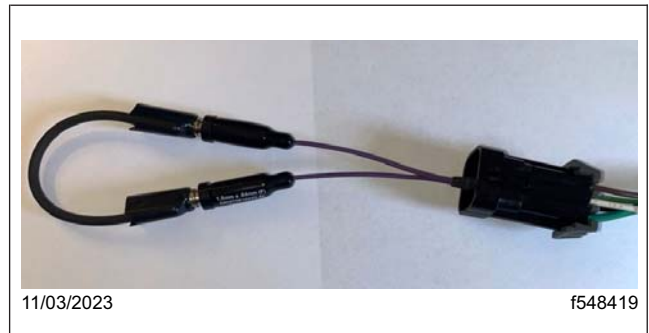

Fig. 95, Test Jumper Wire Installed in the Dual Plow Light Interface Connector Between Pin E (white wire added) and Pin B (ground)

November 2023
SF678 A
(Revised December 2023)

- 39.2 Turn the ignition key to the 'Run' position, then turn the headlight switch to the ON position. Verify that the headlights and all marker lights are on. See **Fig. 96**.
- 39.3 Turn the plow light switch to the ON position, and verify the following:
- Headlights should be off and all other marker lights should be on. See **Fig. 97**.

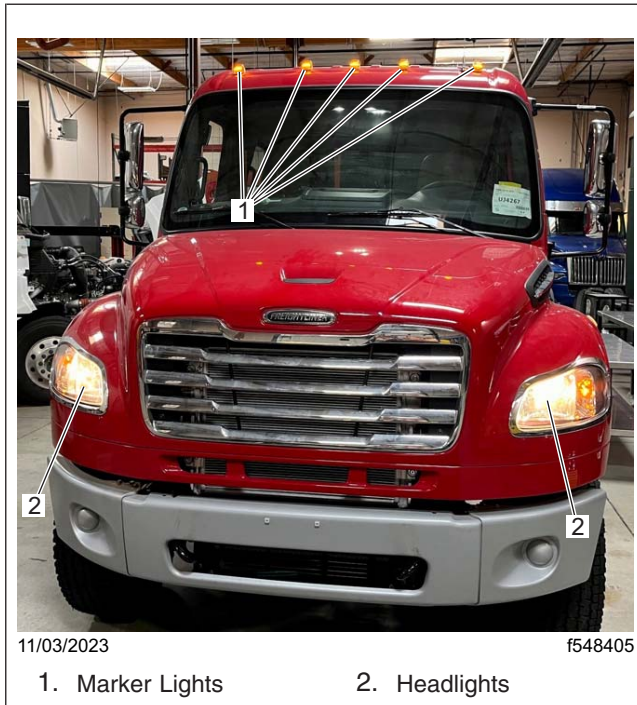

Fig. 96, Verifying the Headlights and Marker Lights Turn On Prior to Turning On the Plow Light Switch



Fig. 97, Verifying the Headlights Turn Off and All Other Marker Lights Remain On After Turning On the Plow Light Switch

November 2023
SF678 A
(Revised December 2023)

- There should be battery voltage (~12.5V) at the low beam output pin on the plow light connector(s):

For single connector plow light interface → Measure the battery voltage at pin C (green wire). See [Fig. 98](#).

For dual connector plow light interface → Measure the battery voltage at pin A (green wire) on both the connectors. See [Fig. 99](#).

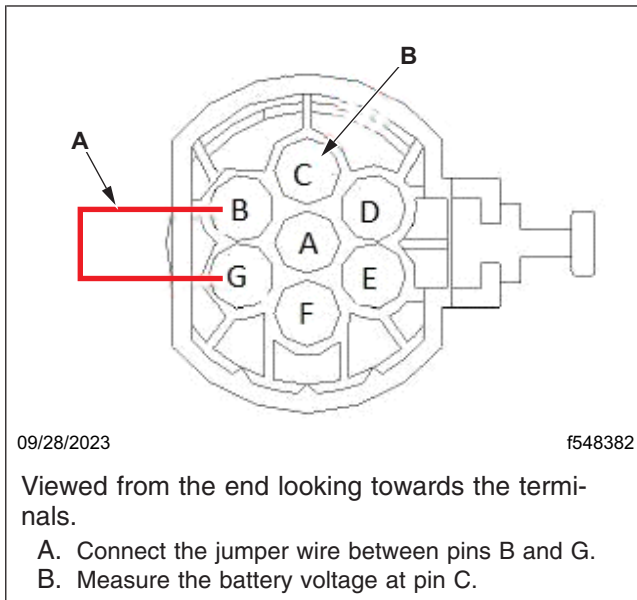

Fig. 98, Single Connector Plow Light Interface Test Jumper and Voltage Check Pin Locations

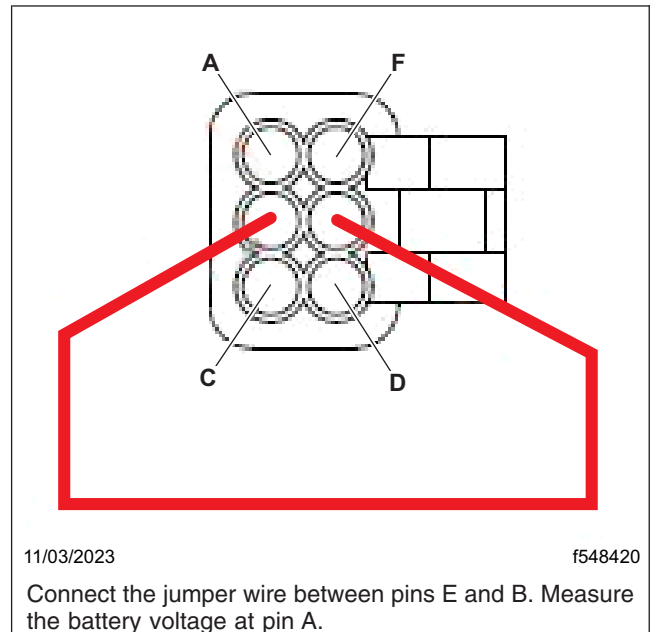

Fig. 99, Dual Plow Light Interface Test Jumper and Voltage Check Pin Locations

- If the headlights and markers lights function correctly, and if there is voltage at the low beam output pin(s) at the plow light connector(s), then go to the next step.
- If the headlights do not turn off, and all other marker lights remain on when the plow switch is turned on, check the installation of the wiring harnesses and re-check the function.
- If voltage is not present at the low beam output pin(s), verify that the parameters were set correctly, and check the wiring installation, especially the connection at the XMC2, then re-check the function.

40. Install dash panels. For instructions, see **Section 60.08** of the *Business Class M2 Plus Workshop Manual*.
41. Clean a spot on the base label (Form WAR259), and attach a campaign completion sticker for SF678 (Form WAR261), indicating this work has been completed.