

2024 bZ4X Pre-Delivery Service (PDS)

Service Category General

Section Pre-Delivery Service

Market USA

Toyota Supports
 ASE Certification 

Applicability

YEAR(S)	MODEL(S)	ADDITIONAL INFORMATION
2024	bZ4X	

Introduction

Pre-Delivery Service (PDS) is a critical step in satisfying our new car customers. Customer feedback indicates the following areas deserve special attention when performing PDS:

- Careful inspection for paint chips/scratches and body dents/dings.
- Proper operation of electrical accessories (including interior light, clock, and radio reset).
- Interior cleanliness.
- Proper function of mechanical systems.

Customer retention and proper maintenance of vehicles are and have always been a major focus for Toyota. To help remind customers that regular service is essential to the proper maintenance of the vehicle, dealers are required to install a service reminder sticker before delivery. By doing this, customers will be reminded to return to your dealership for service. Your current service reminder sticker may be used. (See PDS Check Sheet item 8 of “Final Inspection and Cleaning.”)

This bulletin contains the PDS procedures that apply specifically to 2024 model year bZ4X vehicles. A universal PDS [Check Sheet](#) that contains PDS steps that apply to all 2024 model year Toyota vehicles has been developed. To properly perform a complete PDS, you must complete all procedures contained in this TSB as well as the universal PDS [Check Sheet](#).

In addition, if the vehicle is stored for over 30 days, be sure to follow [Long-Term Vehicle Storage Guidelines](#) and [Battery Electric Vehicle \(BEV\) Traction Battery Long-Term Maintenance Guidelines](#).

2024 bZ4X Pre-Delivery Service (PDS)

Table of Contents

- [Warranty Policy](#)..... 3
- [Warranty Information](#)..... 3
- [Required Tools & Equipment](#) 3
- [D/C Cut Fuse Installation](#) 4
- [Front License Plate and Mounting Bracket Installation](#) * 5
- [Front and Rear Emergency Towing Eyelet Removal and Hole Cover Installation](#)..... 7
- [Power Back Door Initialization](#) * 9
- [Tire Pressure Warning System \(TPWS\) Initialization](#)..... 9
- [Enable Hybrid Battery Thermal Keep Control Mode](#) * 9
 - [Confirm Hybrid Battery Thermal Control Mode State](#) 10
 - [Set Hybrid Battery Thermal Keep Control Mode](#) 11
- [Head Unit System Reset](#)..... 12
- [Customize ACC Function](#)..... 12
- [Dealer Contact Information for Call Dealer Head Unit Function](#)..... 12
- [Navigation — Set Date & Time by GPS](#) 12

*If applicable.

2024 bZ4X Pre-Delivery Service (PDS)

Warranty Policy

If the need for additional repairs or adjustment is noted during PDS, the required service should be performed under warranty. Reimbursement will be managed under the warranty policy.

The Warranty Policy and Procedures Manual requires that you maintain the completed Check Sheet in the customer's file. If you cannot produce a completed form for each retailed vehicle upon TMS and/or Region/Distributor audit, the PDS payment amount will be subject to debit.

An additional Repair Order completed in conjunction with normal PDS MUST have time punch/flags for service. If multiple repairs are performed, separate time flags MUST be punched for each repair.

Warranty Information

OP CODE	DESCRIPTION	MODEL	TIME	OFF	T1	T2
001013	Pre-Delivery Service (PDS)	bZ4X	1.1	-	-	-

Required Tools & Equipment

REQUIRED EQUIPMENT	SUPPLIER	PART NUMBER	QTY
Techstream ADVi*	ADE	TSADVUNIT	1
Techstream 2.0		TS2UNIT	
Techstream Lite		TSLITEPDLR01	
Techstream Lite (Green Cable)		TSLP2DLR01	

*Essential SST.

NOTE

- Only ONE of the Techstream units listed above is required.
- GTS+ version 2023.03.002.02 or later is required.
- Additional Techstream units may be ordered by calling Approved Dealer Equipment (ADE) at 1-800-368-6787.

2024 bZ4X Pre-Delivery Service (PDS)

D/C Cut Fuse Installation

To minimize battery discharge, the D/C cut fuse (30A) has been removed and stored in the engine compartment relay block. Install the D/C cut fuse (30A) and confirm ALL related Diagnostic Trouble Codes (DTCs) are cleared.

Figure 1.

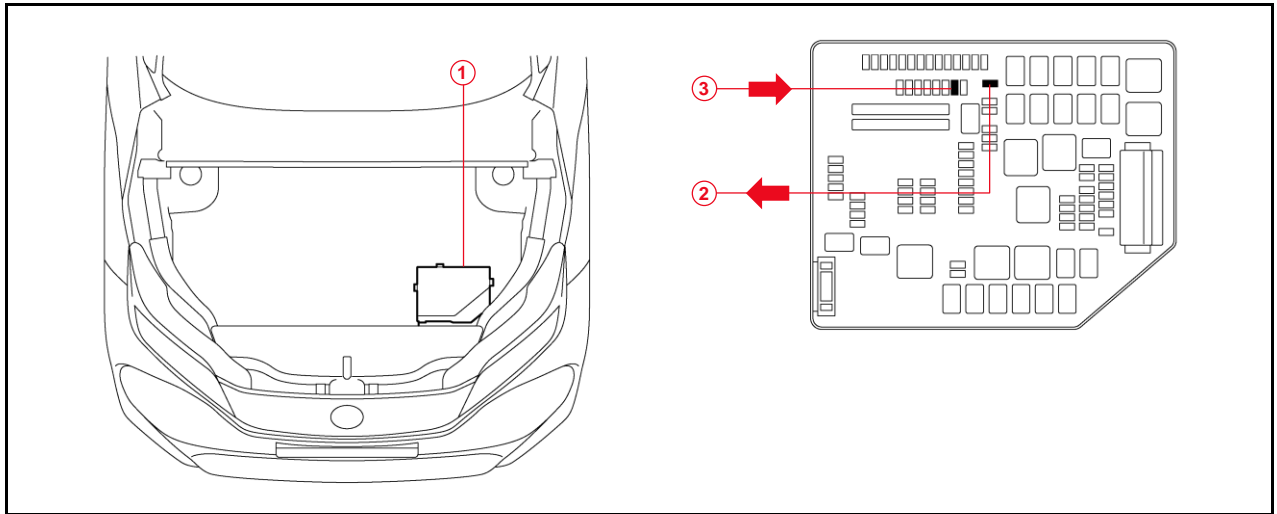

1	Relay Block
2	Remove the D/C Cut Fuse (30A)

3	Install the D/C Cut Fuse (30A) (Original Location)
----------	---

NOTE

- With the D/C cut fuse (30A) removed, if ANY DTCs are detected when the ignition is turned ON during transportation, use Global Techstream Software (GTS+) to clear ALL DTCs AFTER ensuring that there are NO malfunctions.
- While the vehicle is stored at the dealership, disconnect the negative (-) battery terminal to prevent battery discharge. Refer to [T-SB-0024-23](#) *Battery Maintenance During PDS* for battery maintenance information.

2024 bZ4X Pre-Delivery Service (PDS)

Front License Plate and Mounting Bracket Installation

The front license plate bracket and two self-tapping screws are loaded in the luggage compartment at the assembly plant. Follow this procedure to install the front license plate bracket and front license plate in states where it is required by law.

1. Align holes "A" of the mounting bracket with the dimples on the front bumper cover and mark the location of holes "B" on the radiator lower grille.

NOTE

- Holes "A" are used for installation of the mounting bracket to the radiator lower grille.
- Holes "B" are used for the installation of the front license plate to the mounting bracket.

Figure 2.

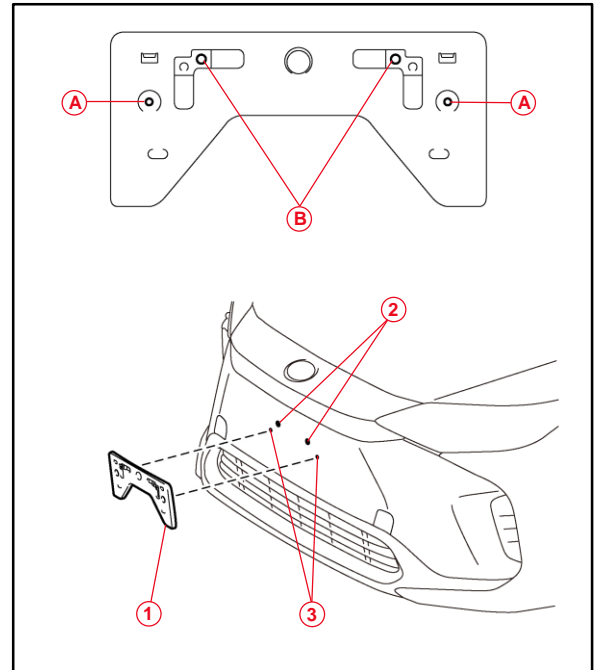

1	Mounting Bracket
2	Mark and Drill Hole
3	Dimples

2024 bZ4X Pre-Delivery Service (PDS)

Front License Plate and Mounting Bracket Installation (continued)

2. Install the mounting bracket to the front bumper cover by attaching the two self-tapping screws into the dimples.

NOTICE

Do **NOT** overtighten the self-tapping screws.

Figure 3.

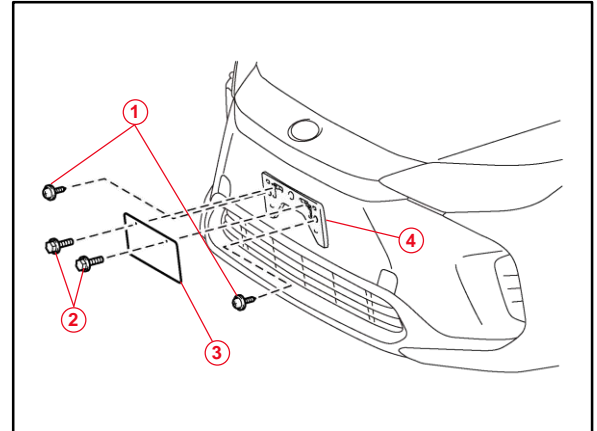

1	Self-tapping Screws
2	Bolts
3	Front License Plate
4	Mounting Bracket

3. Install the front license plate to the mounting bracket at holes "B" using two noncorroding bolts with the following dimensions:

Length: 15.0 mm (0.59 in.)

Diameter: 6.0 mm (0.24 in.)

Figure 4.

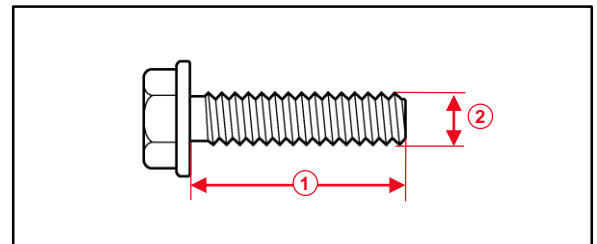

1	Length
2	Diameter

2024 bZ4X Pre-Delivery Service (PDS)

Front and Rear Emergency Towing Eyelet Removal and Hole Cover Installation

1. Remove the front AND rear emergency towing eyelets from the front and rear bumpers by turning them counterclockwise.

HINT

If it is difficult to loosen the emergency towing eyelet(s), use a steel bar.

Figure 5.

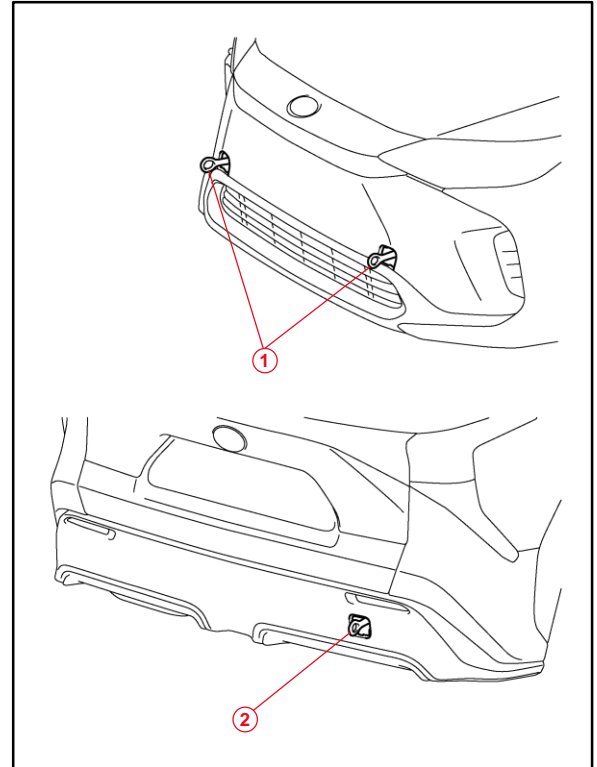

1	Front Emergency Towing Eyelets
2	Rear Emergency Towing Eyelet

2. Place one of the removed emergency towing eyelets into the luggage tray in the luggage compartment.

HINT

Dispose of the other removed emergency towing eyelet(s).

Figure 6.

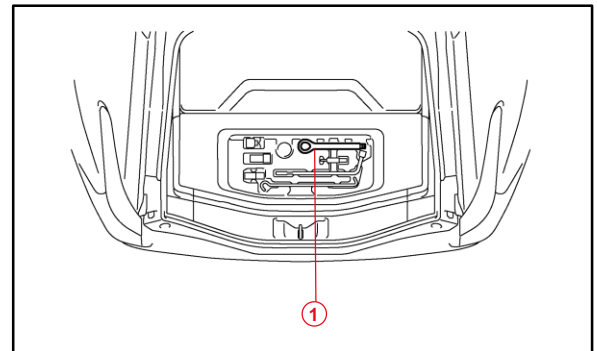

1	Emergency Towing Eyelet
----------	--------------------------------

2024 bZ4X Pre-Delivery Service (PDS)

Front and Rear Emergency Towing Eyelet Removal and Hole Cover Installation (continued)

3. Install the front and rear emergency towing eyelet hole covers, which are stored in the console box, onto the front and rear bumpers.
 - A. Insert the arrow-shaped part of the emergency towing eyelet hole cover "A" into the eyelet hole "B" as shown.
 - B. Install the emergency towing eyelet hole cover to the hole of the bumper.

NOTE

Make sure the front emergency towing eyelet cover is installed in the front, and the rear emergency towing eyelet cover is installed in the rear.

Figure 7.

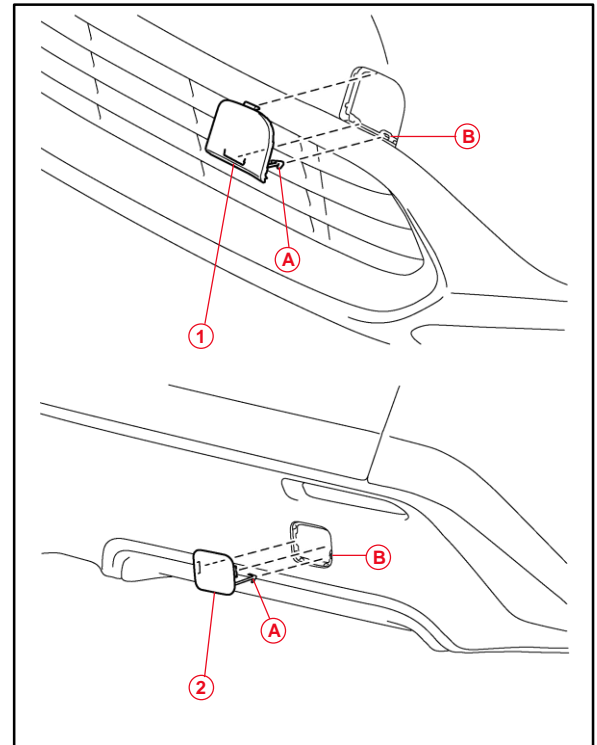

A	Arrow-shaped Part
B	Eyelet Hole
1	Front Emergency Towing Eyelet Hole Cover
2	Rear Emergency Towing Eyelet Hole Cover

2024 bZ4X Pre-Delivery Service (PDS)

Power Back Door Initialization

Refer to the applicable Repair Manual for the power back door [initialization procedure](#).

Tire Pressure Warning System (TPWS) Initialization

Refer to the applicable Repair Manual for the TPWS [initialization procedure](#). Note the spare tire does NOT have a TPWS sensor.

NOTE

To adjust the tire pressure correctly when the outside temperature is significantly colder than the shop temperature, perform a Health Check using GTS+ and select the compensation tire pressure checkbox. Compensation pressures will display on the Health Check results screen. Adjust the tire pressure when the tires are cold.

Enable Hybrid Battery Thermal Keep Control Mode

HV/EV battery may be frozen in extremely cold areas. As a result, the HV/EV battery may become excessively weak, and the system may NOT be able to be started. By enabling HV/EV Battery Thermal Keep Control Mode, it is possible to warm the HV/EV battery and maintain its current temperature in order to prevent it from becoming excessively weak.

When this mode is set to ON, the timer charging settings are canceled at temperatures of 14°F (-10°C) or lower. Charging will begin immediately when the charging cable is connected to the vehicle.

Table 1. HV/EV Battery Thermal Keep Control Mode

PURPOSE	CONDITION	OPERATION
To prevent HV/EV battery from freezing.	<ul style="list-style-type: none"> Ambient temperature is 14°F (-10°C) or lower. Charging cable is connected to vehicle. 	<ul style="list-style-type: none"> Begins to warm the HV/EV battery to maintain its current temperature when the ambient temperature drops to 14°F (-10°C) or lower when the charging cable is connected to the vehicle. To prevent the HV/EV battery from freezing when a charging start time is set, when the HV/EV Battery Thermal Keep Mode is enabled, the charging timer will be disabled, and charging will begin immediately when the charging cable is connected to the vehicle.

To enable HV/EV Battery Thermal Keep Control Mode, it is necessary to use GTS+ during PDS at the dealership.

2024 bZ4X Pre-Delivery Service (PDS)

Enable Hybrid Battery Thermal Keep Control Mode (continued)

Confirm Hybrid Battery Thermal Keep Control Mode State

1. Connect the Techstream to the DLC3.
2. Turn the power switch IG-ON.
3. Read the Data on GTS+ software by entering the following menus: *Powertrain – HV Battery – Data List – Hybrid Battery Thermal Keep Control Mode Status.*
4. Check the results by referring to the following table:

Table 2.

TESTER DISPLAY	MEASUREMENT ITEM	RANGE	NORMAL CONDITION
Hybrid Battery Thermal Keep Control Mode Status	Hybrid Battery Thermal Keep Control Mode State	ON or OFF	ON: Enabled OFF: Disabled

2024 bZ4X Pre-Delivery Service (PDS)

Enable Hybrid Battery Thermal Keep Control Mode (continued)

Set Hybrid Battery Thermal Keep Control Mode

1. Connect the Techstream to the DLC3.
2. Turn the power switch to IG-ON.
3. Enter the following menus: *Powertrain – HV Battery – Utility – Hybrid Battery Thermal Keep Control Mode*.

Figure 8.

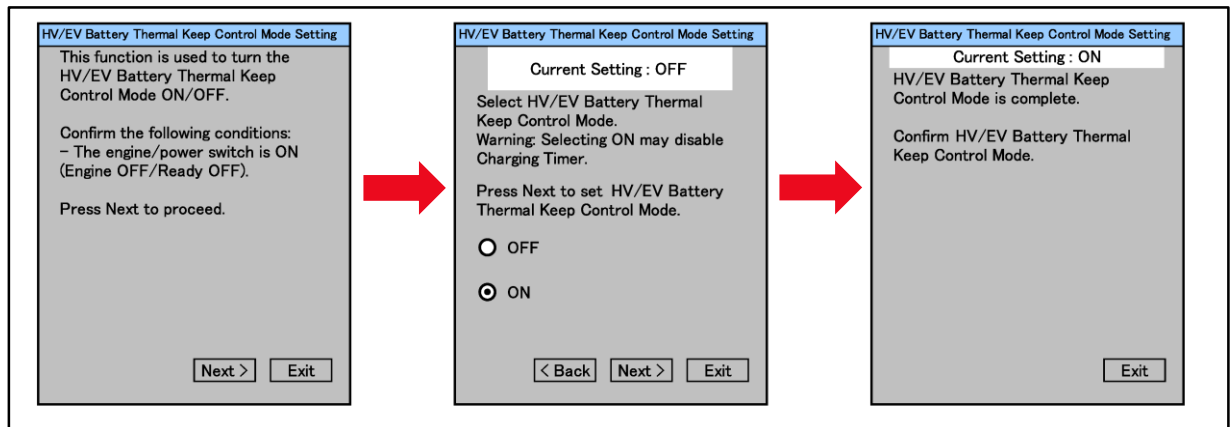

4. Confirm the following message is displayed:
“This function is used to turn the Hybrid Battery Thermal Keep Control Mode ON / OFF.”
5. Confirm that the conditions displayed on the screen are met and then press Next.

NOTE

The power switch is ON (Ready OFF).

6. Confirm the following message is displayed:
“Select Hybrid Battery Thermal Keep Control Mode.”
7. Select ON and press Next.

NOTICE

Selecting ON may disable the charging timer.

8. Confirm the following message is displayed:
“Hybrid Battery Thermal Keep Control Mode is complete.”

2024 bZ4X Pre-Delivery Service (PDS)

Head Unit System Reset

Prior to selling a Toyota vehicle, please confirm that the welcome screen with language options appears on the head unit display when ignition is switched to the ON position. There may be instances where the welcome screen with language options may not properly appear on the head unit display.

If the welcome screen showing language options is not displayed, complete the following steps:

1. Select the Settings option (gear icon).
2. Scroll down and select the Info & Security option.
3. The System Reset dialogue box will appear. Select Reset to confirm the resetting of system.
4. Confirm that the welcome screen with language options is now displayed.

Customize ACC Function

The pre-startup function detects when a user enters the vehicle and energizes the audio head unit (+BA) so that the multimedia system can quickly be used. This function is not enabled at the factory to reduce parasitic current draw in transit and storage. To enable this function, it is necessary to set the ACC customization function in the navigation display to OFF.

1. Turn the engine switch (power switch) to the ON position (ON mode).
2. Enter the following menus: *Settings – Vehicle Customization – Utility – ACC Customize*.
3. Change the setting to OFF.

Dealer Contact Information for Call Dealer Head Unit Function

Refer to the Multimedia System Owner's Manual to add [dealer contact information](#).
See section 2-9 *Vehicle Settings – Setting Dealer Information*.

Navigation — Set Date & Time by GPS

Prior to vehicle delivery, it is necessary to turn the Set Date & Time by GPS setting to the ON position.

1. Turn the engine switch (power switch) to the ON position (ON mode).
2. Navigate the following menus in the head unit: *Settings – General – Date & Time – Set date & time by GPS*.
3. Ensure the Set Date & Time by GPS function is set to the ON position.