

**December 15, 2023**

Version 1

## MIL Comes on with DTC P0441

### AFFECTED VEHICLES

Year	Model	Trim Level	VIN Range
2019–24	Odyssey	ALL	ALL
2019–22	Pilot	ALL	ALL
2019–23	Ridgeline	ALL	ALL
2019–23	Passport	ALL	ALL

### SYMPTOM

MIL comes on during vehicle operation.

### POSSIBLE CAUSE

Due to variations in the purge control solenoid valve spring, the valve wears unevenly and intermittently sticks. This may result in setting DTC P0441 (Evaporative Emission (EVAP) System Purge Flow Malfunction).

### CORRECTIVE ACTION

Replace the purge control solenoid valve, then do an EVAP system function test with the i-HDS.

### PARTS INFORMATION

Part Name	Part Number	Quantity
Purge Control Solenoid	36162-5G0-A02	1

### WARRANTY CLAIM INFORMATION

The normal warranty applies.

Operation Number	Description	Flat Rate Time	Defect Code	Symptom Code	Template ID	Failed Part Number
1201R7	Replace the purge control solenoid valve (includes EVAP function test)	0.5 hr	03214	03217	A23091A	36162-5G0-A01

Skill Level: Repair Technician

**CUSTOMER INFORMATION:** The information in this bulletin is intended for use only by skilled technicians who have the proper tools, equipment, and training to correctly and safely maintain your vehicle. These procedures should not be attempted by “do-it-yourselfers,” and you should not assume this bulletin applies to your vehicle, or that your vehicle has the condition described. To determine whether this information applies, contact an authorized Honda automobile dealer.

**REPAIR PROCEDURE**

- 1. **Except Pilot:** Remove the engine cover.

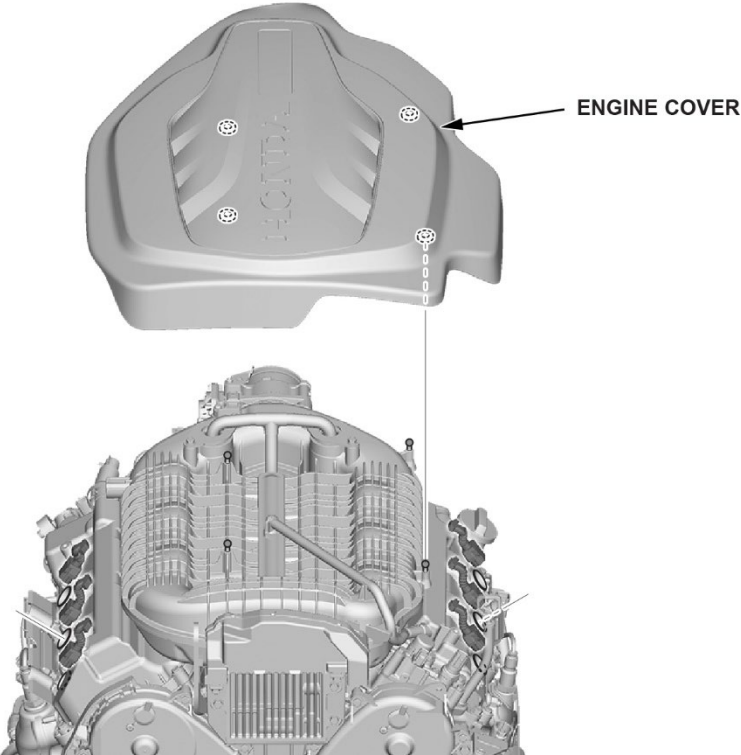

2. Disconnect EVAP cannister purge control solenoid valve connector and hose, then remove valve.

**ODYSSEY:**

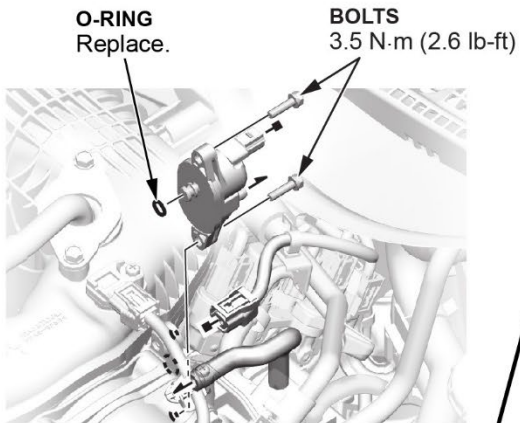

**PASSPORT:**

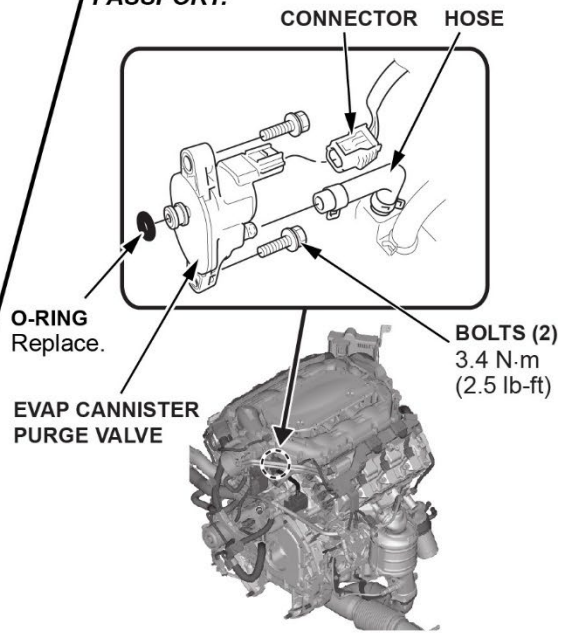

**PILOT:**

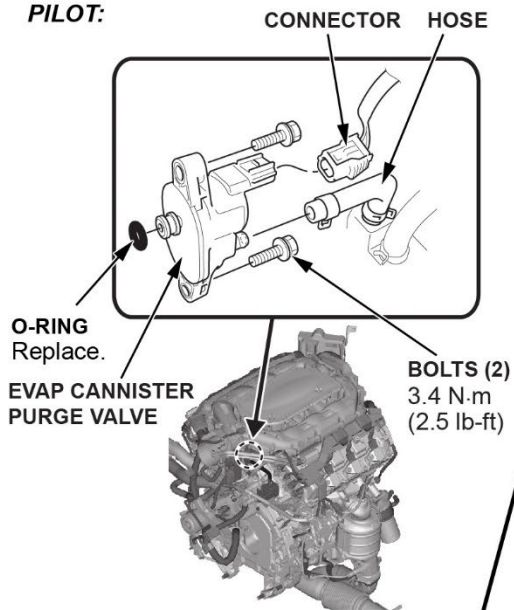

**RIDGELINE:**

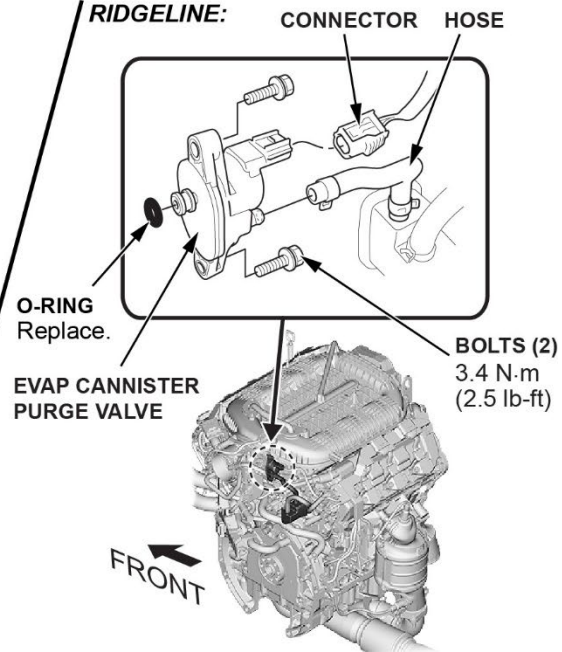

3. Replace with a new purge control solenoid, and then install parts in reverse order.

## REPAIR VERIFICATION

1. Start i-HDS with DST-I.
2. Select **Connect to the Vehicle**.
3. Select **Function Test**.
4. Select **PGM-FI EVAP Test**.
5. Select **Function Test**.
6. Select **EVAP Test**.
7. If the EVAP function test passes, return the vehicle to the customer.  
If the EVAP function test stops and fails, follow normal troubleshooting.