

Rear Spoiler Control Unit Replacement - Follow Procedure (134/23)

Model Line: **Panamera (971)**

Model Year: **As of 2017 up to 2020**

Concerns: **Control unit for rear spoiler**

Cause: **The previous rear spoiler control unit is no longer available for the Panamera (971, model year 2017–2020). For this reason, the rear spoiler control unit for the Panamera (971, from model year 2021) must be used if it requires replacement.**

Action: To facilitate installation and function of the rear spoiler control unit of the second generation Panamera in a first-generation Panamera, the rear lid wire harness **and** the rear spoiler wire harness must be adapted in the vehicle.

Procedure:

- Replacing the previous rear spoiler control unit with a second-generation rear spoiler control unit on the Panamera
- Reworking rear lid ⇒ *Affected rear lid wire harness and rear spoiler wire harness -1-* wire harness
- Reworking rear spoiler ⇒ *Affected rear lid wire harness and rear spoiler wire harness -2-* wire harness
- Re-coding control unit for rear spoiler



Information

Minimum requirement for control unit coding: PIWIS Tester Software Version **42.300.030**

**Information**

Two different rear spoiler variants are available in the Porsche Panamera. These differ in terms of different extension options.

For this reason, the work procedure for reworking varies:

- **2D** rear spoiler work procedure for the Panamera and Panamera S vehicles
- **2D+** rear spoiler work procedure for the Panamera GTS, Panamera Turbo and Panamera Turbo S vehicles

**Information**

If rework on the two wire harnesses has already been performed in the past, only the rear spoiler control unit must be replaced if the rear spoiler control unit needs to be replaced again.

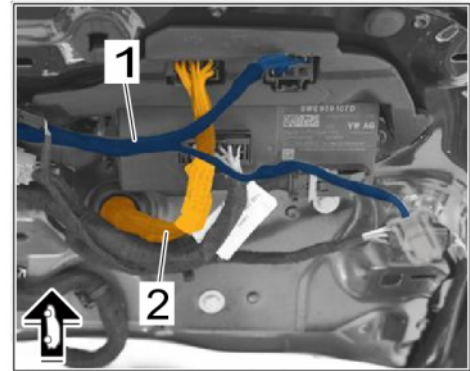

Affected rear lid wire harness and rear spoiler wire harness

Required parts and materials

Parts Info:	Part No.	Designation – Location	Number
	PAA907483	⇒ Control unit for rear spoiler adjustment	1 piece
	974907298	⇒ Holder for rear spoiler control unit	1 piece
	971827715B	⇒ Damping piece – Control unit for rear spoiler adjustment	1 piece
	971998213H	⇒ Rear lid wire harness	1 piece
	971974224F	⇒ Rear spoiler wire harness	1 piece

Materials: **Required materials** (usually already available in the Porsche Center)

Part No.	Designation	Quantity
...	⇒ Fleece adhesive tape, approx. 19 mm/ 0.75 in wide e.g. TESA 51616 ID	Quantity as required
...	⇒ Connecting sleeve (crimping sleeve) – commercially available	Quantity as required
...	⇒ Heat shrink-fit hose – commercially available	Quantity as required

Required tool

- Tools:
- Torque wrench, 0.4-2 Nm (0.3-1.5 ftlb.), e.g. **VAS 6253A - torque wrench, 0.4-2 Nm (0.3-1.5 ftlb.)**
 - Torque wrench, 2-10 Nm (1.5-7.5 ftlb.), e.g. **V.A.G 1783 - Torque wrench, 2-10 Nm (1.5-7.5 ftlb.)**
 - Torque wrench, 6-50 Nm (4.5-37 ftlb.), e.g. **V.A.G 1331A - torque spanner, 6-50 Nm (4.5-37 ftlb.)**
 - **VAS 1978/3 - Stripping pliers**
 - **VAS 1978/1A - Crimping pliers**
 - **VAS 1978/14A - Hot air gun**
 - **P90999 - PIWIS Tester 4**
 - Battery charger with a current rating of **at least 90 A**, e.g. **VAS 5908 - battery charger 90A**. For further information about the battery chargers to be used, see the corresponding Workshop Manual.
⇒ *Workshop Manual '2X00IN Battery trickle charge'*

Replacing control unit for rear spoiler



Information

The previously installed rear spoiler control unit does not have a separate control unit holder.

- Work Procedure:
- 1 Remove previous control unit for rear spoiler.
⇒ *Workshop Manual '667419 Removing and installing control unit for rear spoiler'*
 - 2 Clip in **new** rear spoiler control unit with changed component version in **new** control unit holder.

- 3 Position rear spoiler control unit ⇒ *Control unit for rear spoiler -1-* with rear spoiler control unit holder in rear lid and push in.
- 4 Position foam part ⇒ *Control unit for rear spoiler -3-*.
- 5 Determine further work procedure using the table.

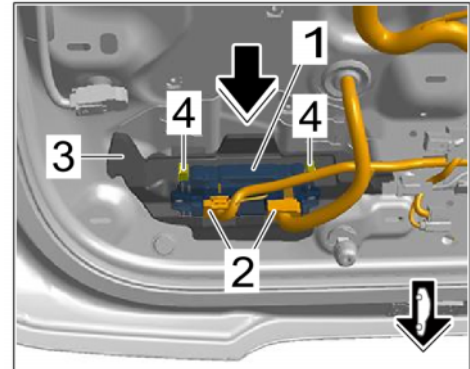

Control unit for rear spoiler

Assessment	Action
Vehicles with 2D rear spoiler. <ul style="list-style-type: none"> • Porsche Panamera • Porsche Panamera S 	Continue with: ⇒ <i>Technical Information '667419 Adjust rear lid wire harness and rear spoiler wire harness (2D rear spoiler)'</i>
Vehicles with 2D+ rear spoiler. <ul style="list-style-type: none"> • Porsche Panamera GTS • Porsche Panamera Turbo • Porsche Panamera Turbo S 	Continue with: ⇒ <i>Technical Information '667419 Adjust rear lid wire harness and rear spoiler wire harness (2D+ rear spoiler)'</i>

Adjust rear lid wire harness and rear spoiler wire harness (2D rear spoiler)



Information

This rework manual describes how to adapt the 2D rear spoiler of the Porsche Panamera and of the Porsche Panamera S.

2D rear spoiler (*without lateral adjustment*)



Information

The vehicle-side electrical plug connections of the previous rear spoiler control unit are not compatible with the second-generation Panamera rear spoiler control unit.

For this reason, the rear lid and rear spoiler wire harnesses installed in the vehicle must be reworked. For this purpose, a rear lid wire harness (971998213H) and a rear spoiler wire harness (971974224F) of the second-generation Panamera are required.

- Work Procedure: 1 Remove the sheath of the rear lid wire harness installed in the vehicle ⇒ *Affected rear lid wire harness and rear spoiler wire harness -1-*, rear spoiler wire harness ⇒ *Affected rear lid wire harness and rear spoiler wire harness -2-* and the two rear lid wire harnesses (971998213H) and rear spoiler (971974224F) of the second generation Panamera from the affected plug connection on a length of approx. 200 mm/ 7.87 in.

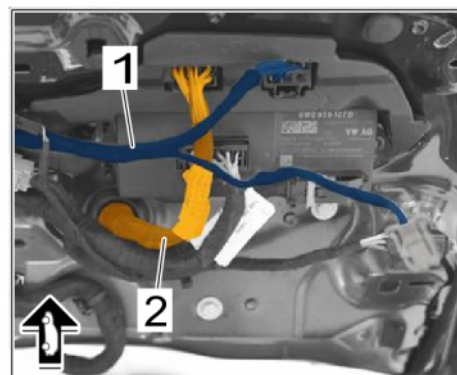

Affected rear lid wire harness and rear spoiler wire harness



Information

Choose a place for the joint, where there is enough space for connecting all the individual lines. Do not cut the lines too short, in case they have to be laid in a different position if there is insufficient space in the area of the joint.



Information

Always exercise care during the individual work steps for stripping insulation from, crimping and shrinking/insulating the electric lines.

The procedures for stripping insulation from, crimping, and shrinking/insulating the electric lines must be complied with and observed. The procedures are described in detail in the **Nr.155-2 - Repair kit for wire harnesses**.

Crimping samples must be prepared before beginning work.

If more than one line needs to be repaired, the crimp connectors may not be directly next to each other. To ensure that the circumference of the wire harness is not too large, the crimp connectors must be offset.

2 Rework **rear lid wire harness**.

2.1 Prepare **new** rear lid wire harness for the second generation Panamera.

2.1.1 Cut electric lines to different lengths (to allow for shrink-fit connections). Start at a length of approx. 200 mm/ 7.87 in and continue in the direction of the plug connection.

2.2 Prepare **previous** rear lid wire harness in the vehicle.

2.2.1 Disconnect electrical line PIN 1 (red / white, 0.5 mm) on the vehicle rear lid wire harness and wear it watertight using a shrink-fit hose. The electrical line is no longer required. → *Insulated line (example illustration)*

2.3 In accordance with the following table, connect the new wire harness of the second-generation Panamera with the previous rear lid wire harness in the vehicle. Proceed with each line one-by-one as follows:

2.3.1 Slide shrink-fit hoses onto the electric lines.

2.3.2 Strip 10 mm/ 0.39 in of insulation off electrical lines.

2.3.3 Crimp electric lines with crimping pliers using crimping sleeves or a combination of crimp and shrink-fit hose.

2.3.4 Slide shrink-fit hose over the crimp connections and carefully shrink it to make it watertight using the hot air gun.

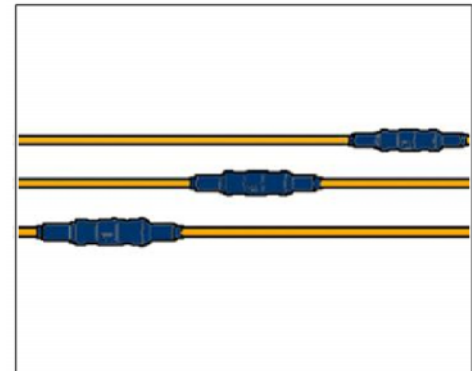

Arrangement of crimp connections

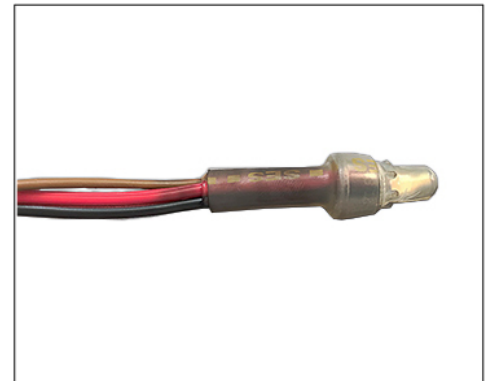

Insulated line (example illustration)

New rear lid wire harness for second-generation Panamera			Previous rear lid wire harness in the vehicle		
PIN	Cable cross-section in mm	Cable color	PIN	Cable cross-section in mm	Cable color
1	2.5	Red / Green	3	2.5	Red / Green
3	0.35	Brown / Red	2	0.35	Brown / Red

4	0.35	White / Brown	5	0.35	White / Brown
5	2.5	Brown	4	2.5	Brown

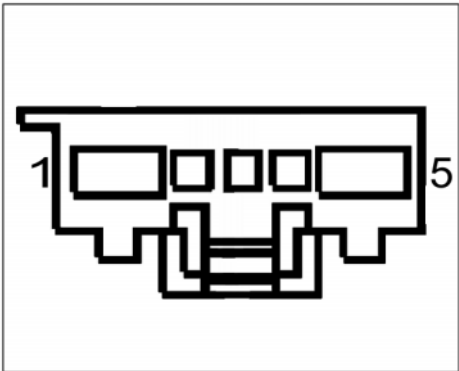

Pin assignment for electric rear lid push-on connector for Panamera G2 II

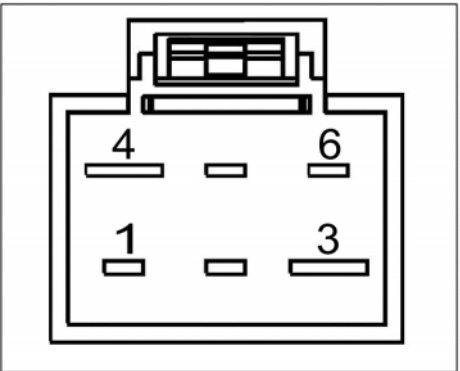

Pin assignment for electric rear lid push-on connector for Panamera G2

3 Rework **rear spoiler wire harness**.

3.1 Prepare **new** rear spoiler wire harness for the second generation Panamera.

3.1.1 Cut electric lines to different lengths (to allow for shrink-fit connections). Start at a length of approx. 200 mm/ 7.87 in and continue in the direction of the plug connection.

3.1.2 Disconnect electrical lines PIN 2 (brown / white, 0.5 mm), PIN 3 (brown / white, 0.5 mm), PIN 11 (brown, 1.0 mm) and PIN 12 (red / white, 1.0 mm) at the wire harness close to the plug connection and wear watertight using a shrink-fit hose. The electrical lines are no longer required. ⇒ *Insulated line (example illustration)*

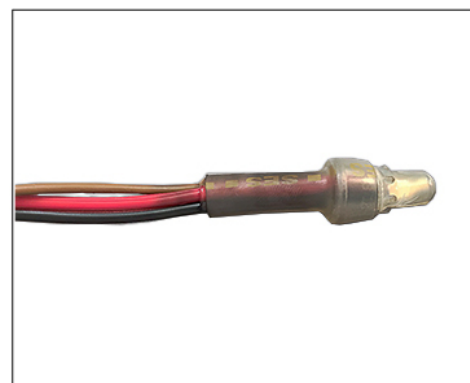

Insulated line (example illustration)

3.2 Prepare **previous** rear spoiler wire harness in the vehicle.

3.2.1 Disconnect electrical lines PIN 3 (brown / white, 0.5 mm), PIN 8 (brown / white, 0.5 mm), PIN 9 (red / white, 1.0 mm) and PIN 10 (brown, 1.0 mm) on the vehicle-side rear spoiler wire harness and wear watertight individually using a shrink hose. The electrical lines are no longer required. ⇒ *Insulated line (example illustration)*

- 3.3 In accordance with the following table, connect the new wire harness of the second-generation Panamera with the existing rear spoiler wire harness in the vehicle. Proceed with each line one-by-one as follows:



Information

The splice connection (connection point of two black electrical lines to a brown electrical line) remains on the vehicle-side wire harness PIN 2 (brown, 0.5 mm) and is crimped on the **brown** electrical line PIN 1 (brown, 0.5 mm) with the **new** rear spoiler wire harness of the second generation Panamera.

- 3.3.1 Slide shrink-fit hoses onto the electric lines.
- 3.3.2 Strip 10 mm/ 0.39 in of insulation off electrical lines.
- 3.3.3 Crimp electric lines with crimping pliers using crimping sleeves or a combination of crimp and shrink-fit hose.
- 3.3.4 Slide shrink-fit hose over the crimp connections and carefully shrink it to make it watertight using the hot air gun.

New rear spoiler wire harness for second-generation Panamera			Previous rear spoiler wire harness in the vehicle		
PIN	Cable cross-section in mm	Cable color	PIN	Cable cross-section in mm	Cable color
1	0.5	Brown	2	0.5	Brown
5	0.5	Red	5	0.5	Red
6	0.5	White	7	0.5	White
7	0.5	Black	4	0.5	Black

9	1.5	Red / White	1	1.5	Red / White
10	1.5	Brown	6	1.5	Brown

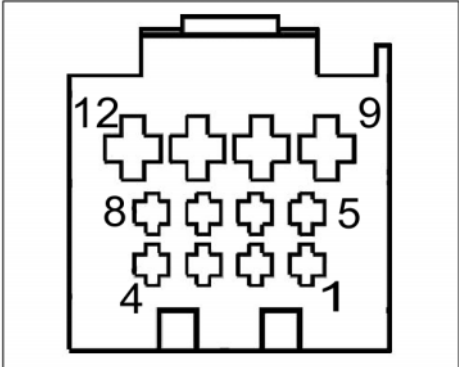
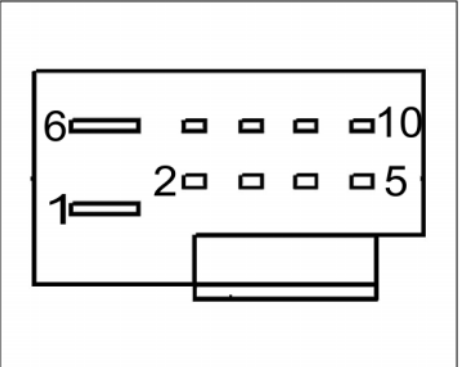
 <p><i>Pin assignment for electric rear spoiler push-on connector for Panamera G2 II</i></p>	 <p><i>Pin assignment for electric rear spoiler push-on connector for Panamera G2</i></p>
---	---

- 4 Wrap the reworked rear lid and rear spoiler wire harness with non-woven adhesive tape up to the respective plug connection.
- 5 Connect electric plug connection for rear spoiler control unit ⇒ *Control unit for rear spoiler -2-* until it locks perceptibly.
- 6 Continue with: ⇒ *Technical Information '667419 Follow-up actions'*

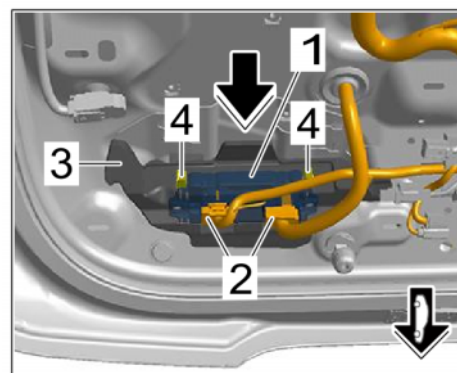

Control unit for rear spoiler

Adjust rear lid wire harness and rear spoiler wire harness (2D+ rear spoiler)**Information**

This rework manual describes how to adapt the 2D+ rear spoiler of the Porsche Panamera GTS, Porsche Panamera Turbo and the Porsche Panamera S.



2D+ rear spoiler (*with lateral adjustment*)

**Information**

The vehicle-side electrical plug connections of the previous rear spoiler control unit are not compatible with the second-generation Panamera rear spoiler control unit.

For this reason, the rear lid and rear spoiler wire harnesses installed in the vehicle must be reworked. For this purpose, a rear lid wire harness (971998213H) and a rear spoiler wire harness (971974224F) of the second-generation Panamera are required.

- Work Procedure: 1 Remove the sheath of the rear lid wire harness installed in the vehicle ⇒ *Affected rear lid wire harness and rear spoiler wire harness -1-*, rear spoiler wire harness ⇒ *Affected rear lid wire harness and rear spoiler wire harness -2-* and the two rear lid wire harnesses (971998213H) and rear spoiler (971974224F) of the second generation Panamera from the affected plug connection on a length of approx. 200 mm/ 7.87 in.

**Information**

Choose a place for the joint, where there is enough space for connecting all the individual lines. Do not cut the lines too short, in case they have to be laid in a different position if there is insufficient space in the area of the joint.

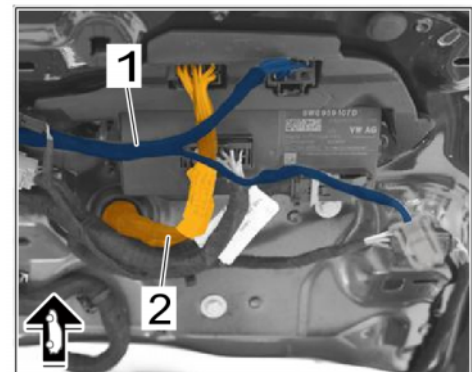

Affected rear lid wire harness and rear spoiler wire harness



Information

Always exercise care during the individual work steps for stripping insulation from, crimping and shrinking/insulating the electric lines.

The procedures for stripping insulation from, crimping, and shrinking/insulating the electric lines must be complied with and observed. The procedures are described in detail in the **Nr.155-2 - Repair kit for wire harnesses**.

Crimping samples must be prepared before beginning work.

If more than one line needs to be repaired, the crimp connectors may not be directly next to each other. To ensure that the circumference of the wire harness is not too large, the crimp connectors must be offset.

2 Rework **rear lid wire harness**.

2.1 Prepare **new** rear lid wire harness for the second generation Panamera.

2.1.1 Cut electric lines to different lengths (to allow for shrink-fit connections). Start at a length of approx. 200 mm/ 7.87 in and continue in the direction of the plug connection.

2.2 Prepare **previous** rear lid wire harness in the vehicle.

2.2.1 Disconnect electrical line PIN 1 (red / white, 0.5 mm) on the vehicle rear lid wire harness and wear it watertight using a shrink-fit hose. The electrical line is no longer required.

2.3 In accordance with the following table, connect the new wire harness of the second-generation Panamera with the previous rear lid wire harness in the vehicle. Proceed with each line one-by-one as follows:

2.3.1 Slide shrink-fit hoses onto the electric lines.

2.3.2 Strip 10 mm/ 0.39 in of insulation off electrical lines.

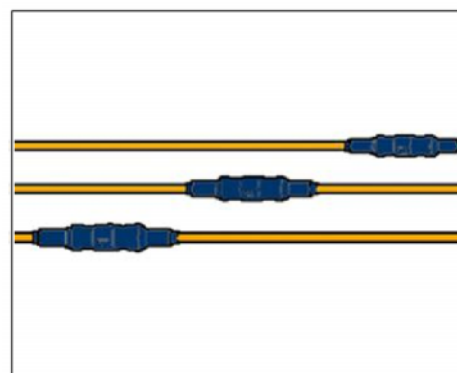

Arrangement of crimp connections

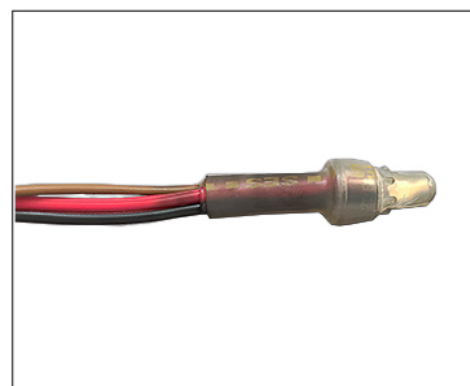

Insulated line (example illustration)

- 2.3.3 Crimp electric lines with crimping pliers using crimping sleeves or a combination of crimp and shrink-fit hose.
- 2.3.4 Slide shrink-fit hose over the crimp connections and carefully shrink it to make it watertight using the hot air gun.

New rear lid wire harness for second-generation Panamera			Previous rear lid wire harness in the vehicle		
PIN	Cable cross-section in mm	Cable color	PIN	Cable cross-section in mm	Cable color
1	2.5	Red / Green	3	2.5	Red / Green
3	0.35	Brown / Red	2	0.35	Brown / Red
4	0.35	White / Brown	5	0.35	White / Brown
5	2.5	Brown	4	2.5	Brown

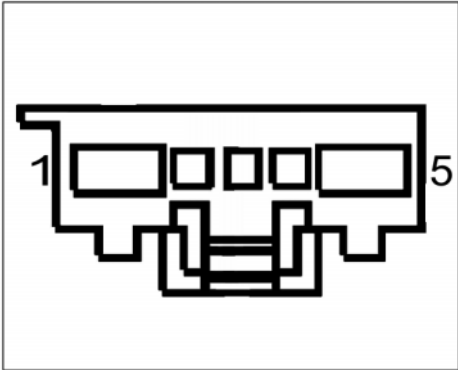
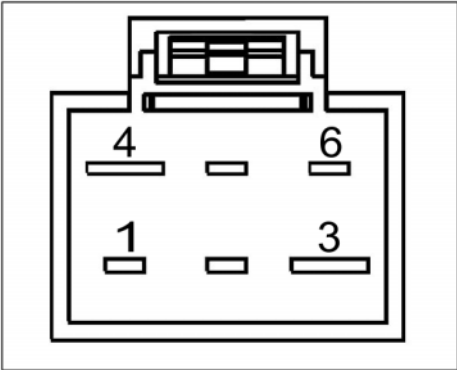
	
<p><i>Pin assignment for electric rear lid push-on connector for Panamera G2 II</i></p>	<p><i>Pin assignment for electric rear lid push-on connector for Panamera G2</i></p>

3 Rework **rear spoiler wire harness**.

- 3.1 Prepare **new** rear spoiler wire harness for the second generation Panamera.
- 3.1.1 Cut electric lines to different lengths (to allow for shrink-fit connections). Start at a length of approx. 200 mm/ 7.87 in and continue in the direction of the plug connection.
- 3.2 In accordance with the following table, connect the new wire harness of the second-generation Panamera with the existing rear spoiler wire harness in the vehicle. Proceed with each line one-by-one as follows:



Information

The splice connection (connection point of two black electrical lines to a brown electrical line) remains on the vehicle-side wire harness PIN 2 (brown, 0.5 mm) and is crimped on the **brown** electrical line PIN 1 (brown, 0.5 mm) with the **new** rear spoiler wire harness of the second generation Panamera.

- 3.2.1 Slide shrink-fit hoses onto the electric lines.
- 3.2.2 Strip 10 mm/ 0.39 in of insulation off electrical lines.
- 3.2.3 Crimp electric lines with crimping pliers using crimping sleeves or a combination of crimp and shrink-fit hose.
- 3.2.4 Slide shrink-fit hose over the crimp connections and carefully shrink it to make it watertight using the hot air gun.

New rear spoiler wire harness for second-generation Panamera			Previous rear spoiler wire harness in the vehicle		
PIN	Cable cross-section in mm	Cable color	PIN	Cable cross-section in mm	Cable color
1	0.5	Brown	2	0.5	Brown
2	0.5	Brown / White	8	0.5	Brown / White
3	0.5	Brown / White	3	0.5	Brown / White
5	0.5	Red	5	0.5	Red
6	0.5	White	7	0.5	White
7	0.5	Black	4	0.5	Black
9	1.5	Red / White	1	1.5	Red / White
10	1.5	Brown	6	1.5	Brown

11	1	Brown	10	1	Brown
12	1	Red / White	9	1	Red / White

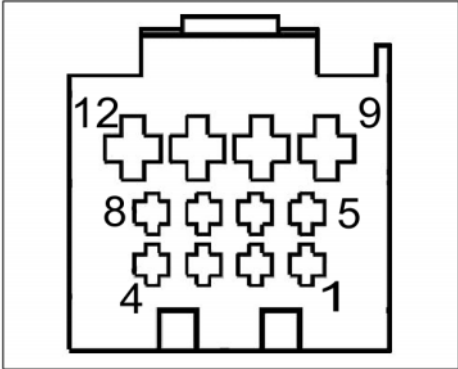
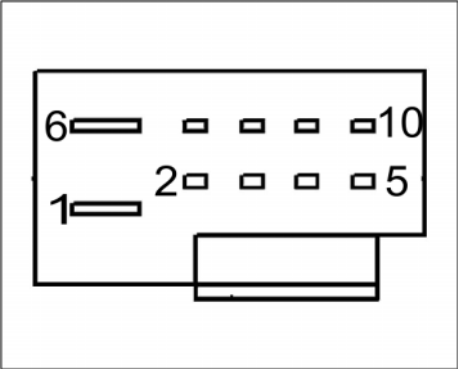
	
<p><i>Pin assignment for electric rear spoiler push-on connector for Panamera G2 II</i></p>	<p><i>Pin assignment for electric rear spoiler push-on connector for Panamera G2</i></p>

- 4 Wrap the reworked rear lid and rear spoiler wire harness with non-woven adhesive tape up to the respective plug connection.
- 5 Connect electric plug connection for rear spoiler control unit ⇒ *Control unit for rear spoiler -2-* until it locks perceptibly.
- 6 Continue with: ⇒ *Technical Information '667419 Follow-up actions'*

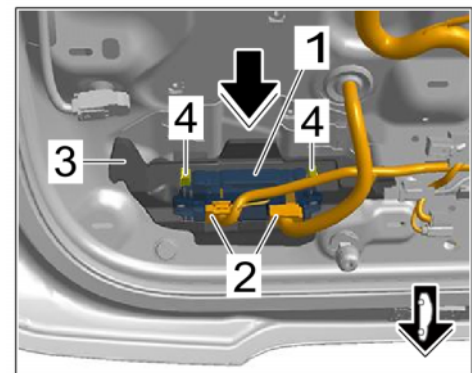

Control unit for rear spoiler

Follow-up actions

- Work Procedure: 1 Install rear lid control unit.
⇒ *Workshop Manual '556819 Removing and installing rear lid control unit'*
- 2 Code rear spoiler control unit.
For procedure, see: ⇒ *Workshop Manual '667455 Replacing control unit for rear spoiler'*
- 3 Adjust rear lid adjustment elements at the bottom.

- 3.1 Loosen screw on adjusting elements ⇒ *Adjuster -1-* and press adjusting elements ⇒ *Adjuster -1-* in completely ⇒ *Adjuster -Arrow A-*.
- 3.2 Press adjusting elements ⇒ *Adjuster -1-* approx. 1 cm/ 0.39 in into the square opening.
- 3.3 Close the lid with your hand by applying slight pressure over the center (handle area) and then open it again.
- 3.4 Pull adjusting elements ⇒ *Adjuster -1-* out again by one notch ⇒ *Adjuster -Arrow A-*

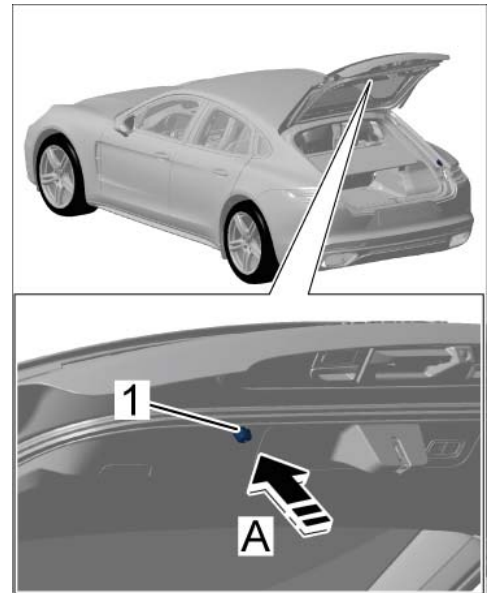

Adjuster

- 4 Tighten screw on adjusting elements ⇒ *Rubber stops -1-*.

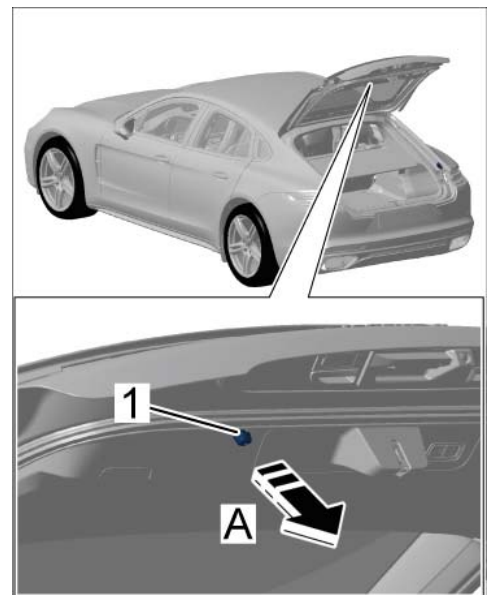

Rubber stops

Working position and PCSS encryption

Labor position:

APOS	Labor operation	I No.
66745545	Replacing control unit for rear spoiler	

PCSS encryption:

Location (FES5)	66740	Rear spoiler control unit
Damage type (SA4)	9735	repair in accordance with PAG instructions

Important Notice: Technical Bulletins issued by Porsche Cars North America, Inc. are intended only for use by professional automotive technicians who have attended Porsche service training courses. They are written to inform those technicians of conditions that may occur on some Porsche vehicles, or to provide information that could assist in the proper servicing of a vehicle. Porsche special tools may be necessary in order to perform certain operations identified in these bulletins. Use of tools and procedures other than those Porsche recommends in these bulletins may be detrimental to the safe operation of your vehicle, and may endanger the people working on it. Properly trained Porsche technicians have the equipment, tools, safety instructions, and know-how to do the job properly and safely. Part numbers listed in these bulletins are for reference only. The work procedures updated electronically in the Porsche PIWIS diagnostic and testing device take precedence and, in the event of a discrepancy, the work procedures in the PIWIS Tester are the ones that must be followed.

© 2023 Porsche Cars North America, Inc.