

# 2024 LS 500 and LS 500h Pre-Delivery Service (PDS)

**Service Category** General

**Section** Pre-Delivery Service

**Market** USA

Toyota Supports  
ASE Certification 

## Applicability

YEAR(S)	MODEL(S)	ADDITIONAL INFORMATION
2024	LS500, LS500H	

## Introduction

Pre-Delivery Service (PDS) is a critical step in satisfying our new car customers. Customer feedback indicates the following areas deserve special attention when performing PDS:

- Careful inspection for paint chips/scratches and body dents/dings.
- Proper operation of electrical accessories (including interior light, clock, and radio reset).
- Interior cleanliness.
- Proper function of mechanical systems.

Customer retention and proper maintenance of vehicles are and have always been a major focus for Lexus. To help remind customers that regular service is essential to the proper maintenance of the vehicle, dealers are required to input their dealer information and set the service reminder on the Navigation Screen before delivery. By doing this, customers will be reminded to return to your dealership for service. (See Page 2 of the LS 500/LS 500h PDS [Check Sheet](#) “Set Dealer and Service Reminder.”)

This bulletin contains the PDS procedures that apply specifically to the 2024 model year LS 500 and LS 500h vehicles. To properly perform a complete PDS, you must complete all procedures contained in this TSB as well as the LS500/LS500h PDS [Check Sheet](#).

In addition, if the vehicle is stored for over 30 days, be sure to follow [Long-Term Vehicle Storage Guidelines](#) .

## 2024 LS 500 and LS 500h Pre-Delivery Service (PDS)

---

### Table of Contents

- [Warranty Information](#)..... 3
- [Required Tools & Equipment](#)..... 3
- [D/C Cut Fuse Installation](#) ..... 4
  - [Vehicles Without Active Stabilizer System \(Non-F Sport Models\)](#)..... 4
  - [Vehicles With Active Stabilizer System \(F Sport Models\)](#) ..... 5
  - [Hybrid Vehicles](#) ..... 7
- [Front License Plate and Mounting Bracket Installation\\*](#) ..... 8
- [Front and Rear Emergency Towing Eyelet Removal and Hole Cover Installation](#)..... 10
- [Front Wheel Opening Extension Pad Installation](#)..... 12
- [Installation of Rubber Body Plugs\\*](#) ..... 13
- [Tire Pressure Warning System \(TPWS\) Initialization](#)..... 14
- [Parking Support Brake System Calibration](#)..... 14
- [Memorize Steering Angle Neutral Point](#)..... 15
  - [Hybrid Engine](#)..... 15
  - [Gasoline Engine](#)..... 16
- [Seating Position Control ECU Initialization](#)..... 16
- [Rear Door Sunshade Initialization](#) ..... 16
- [Head Unit System Reset](#)..... 17
- [Dealer Contact Information for Call dealer Head Unit Function](#) ..... 17
- [Deletion of Vehicle Alert History](#)..... 17
- [Navigation — Set Date & Time by GPS](#) ..... 18

\*If Applicable

## 2024 LS 500 and LS 500h Pre-Delivery Service (PDS)

---

### Warranty Information

OP CODE	DESCRIPTION	TIME	OFFP	T1	T2
N/A	Not Applicable to Warranty	-	-	-	-

### Required Tools & Equipment

REQUIRED EQUIPMENT	SUPPLIER	PART NUMBER	QTY
Techstream ADVi*	ADE	TSADVUNIT	1
Techstream 2.0		TS2UNIT	
Techstream Lite		TSLITEPDLR01	
Techstream Lite (Green Cable)		TSLP2DLR01	

\*Essential SST.

**NOTE**

- Only ONE of the Techstream units listed above is required.
- GTS+ version 2023.03.002.02 or later is required.
- Additional Techstream units may be ordered by calling Approved Dealer Equipment (ADE) at 1-800-368-6787.

## 2024 LS 500 and LS 500h Pre-Delivery Service (PDS)

### D/C Cut Fuse Installation

To minimize battery discharge during transportation and storage, the D/C cut fuses (30A) have been removed at the assembly plant and temporarily stored in the blank spaces of the relay block in the engine compartment. During PDS, remove the D/C cut fuses (30A) from the blank spaces of the relay block in the engine compartment and install them in the locations shown.

#### Vehicles Without Active Stabilizer (Non-F Sport Models)

With the ignition switch OFF, install the D/C cut fuses (30A) into their original locations in the engine compartment relay block.

**Figure 1.**

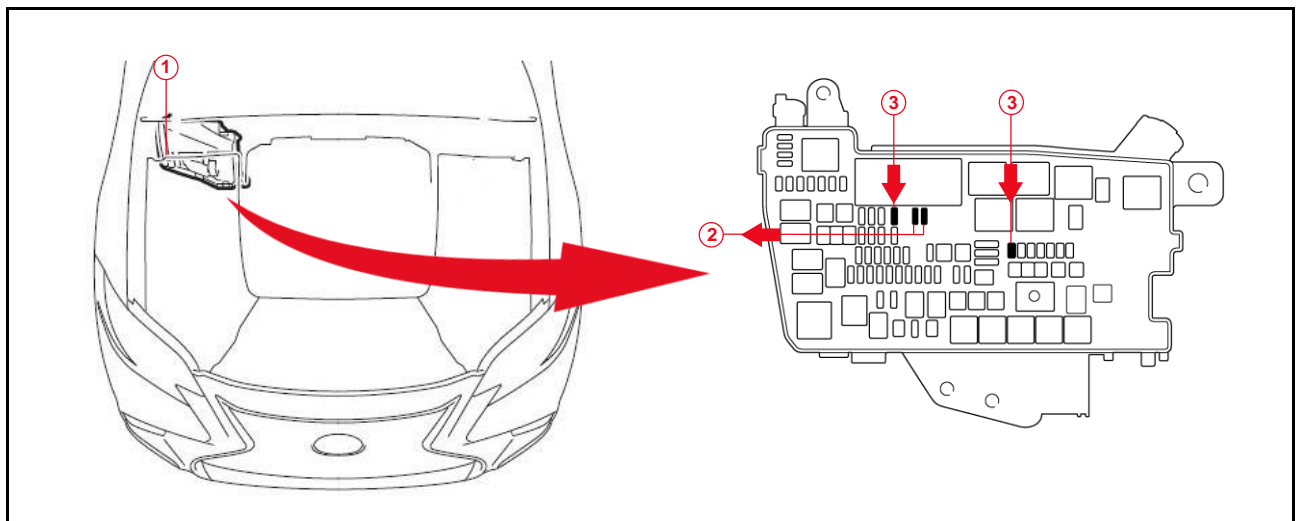

<b>1</b>	<b>Relay Block</b>
<b>2</b>	<b>Remove the D/C Cut Fuses (30A)</b>

<b>3</b>	<b>Install the D/C Cut Fuses (30A) (Original Location)</b>
----------	--

#### NOTE

- With the D/C cut fuses (30A) removed, if ANY DTCs are detected when the ignition is turned on during transportation, use Global Techstream Software (GTS+) to clear ALL DTCs AFTER ensuring that there are no malfunctions.
- While the vehicle is stored at the dealership, disconnect the negative (-) battery terminal to prevent battery discharge. Refer to [L-SB-0016-23 Battery Maintenance During PDS](#) for battery maintenance information.

## 2024 LS 500 and LS 500h Pre-Delivery Service (PDS)

---

### D/C Cut Fuse Installation (continued)

#### Vehicles With Active Stabilizer System (F Sport Models)

1. Push the core of the engine compartment side cover clips and remove them.
  
2. Remove the engine compartment side cover (upper radiator support seal).

**Figure 2.**

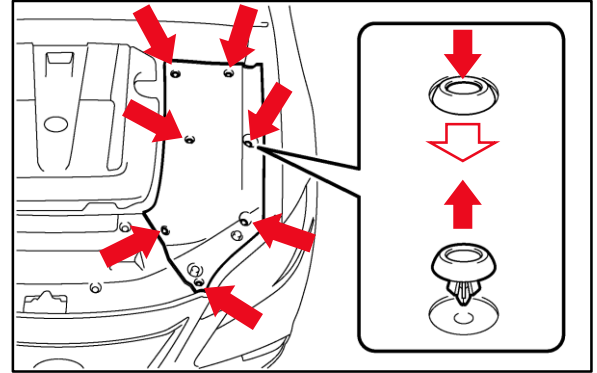

## 2024 LS 500 and LS 500h Pre-Delivery Service (PDS)

### D/C Cut Fuse Installation (continued)

#### Vehicles With Active Stabilizer System (F Sport Models) (continued)

- With the ignition switch OFF, install the D/C cut fuses (30A) into their original locations in the engine compartment relay block.

**Figure 3. Vehicles With Active Stabilizer Suspension System (F Sport)**

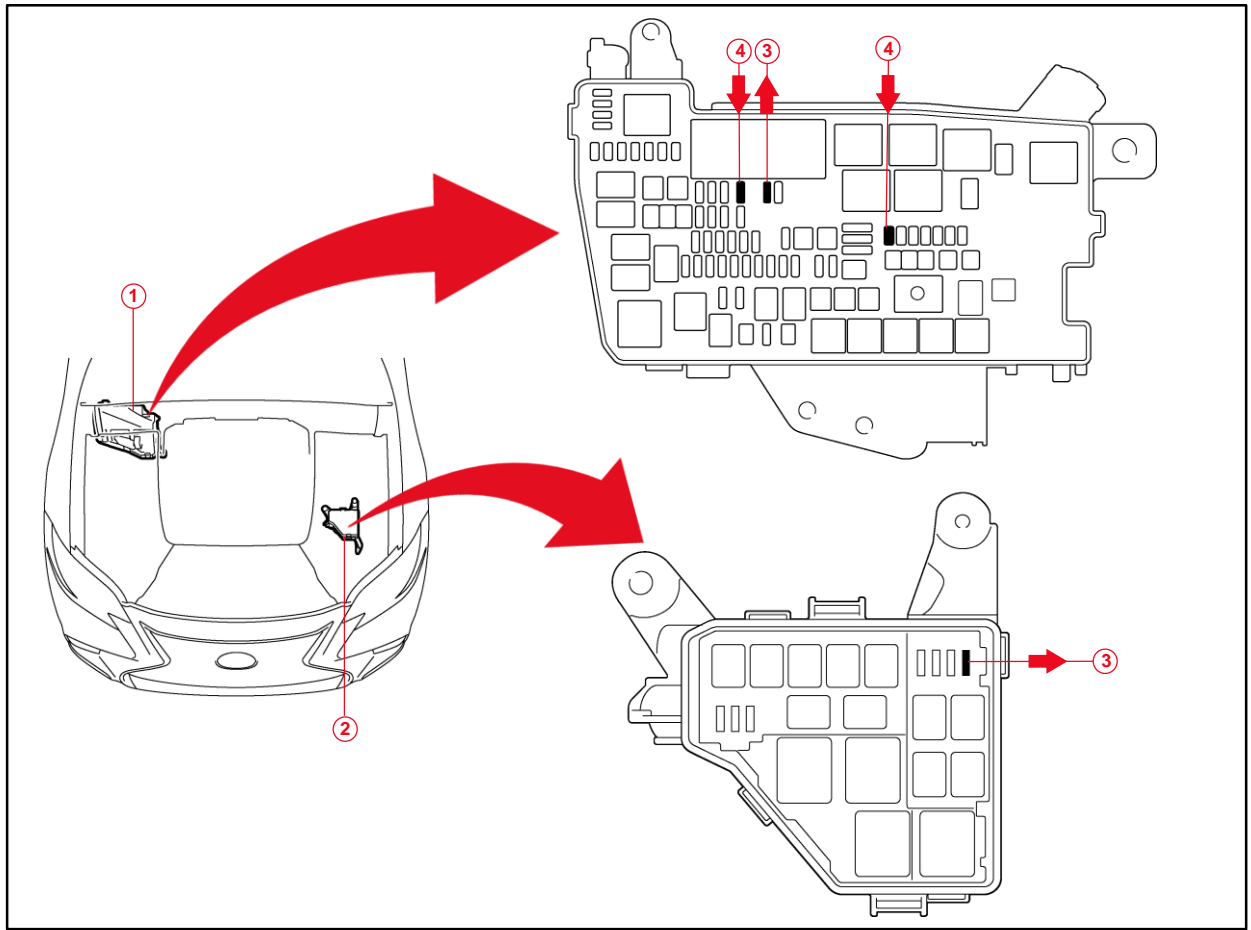

1	Main Relay Block
2	Sub Relay Block

3	Remove the D/C Cut Fuses (30A)
4	Install the D/C Cut Fuses (30A) (Original Location)

**NOTE**

- With the D/C cut fuses (30A) removed, the diagnostic trouble code (DTC) is detected when the ignition is turned on during transportation. Clear all DTCs using GTS+ after checking that there are no malfunctions on the vehicle.
- While the vehicle is stored at the dealership, disconnect the negative (-) battery terminal to prevent battery discharge. Refer to [L-SB-0016-23 Battery Maintenance During PDS](#) for battery maintenance information.

## 2024 LS 500 and LS 500h Pre-Delivery Service (PDS)

### D/C Cut Fuse Installation (continued)

#### Vehicles With Active Stabilizer System (F Sport Models) (continued)

4. Reinstall the engine compartment side cover (upper radiator support seal).
5. Confirm the master warning light is OFF and there are NO warning messages on the multi-informational display.

#### Hybrid Vehicles

With the ignition switch OFF, install the D/C cut fuses (30A) into their original locations in the engine compartment relay block.

**Figure 4.**

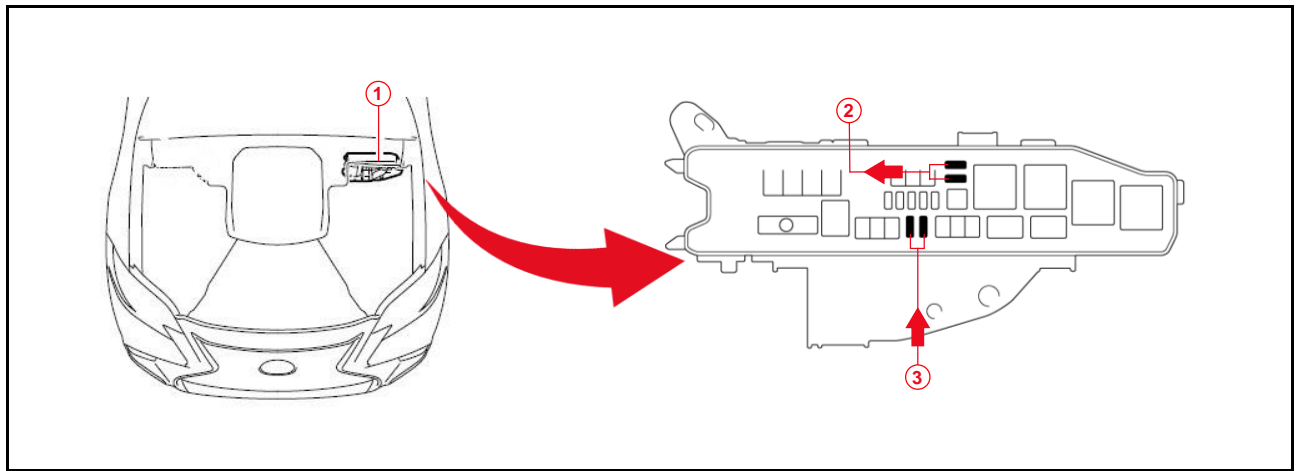

<b>1</b>	<b>Relay Block</b>
<b>2</b>	<b>Remove the D/C Cut Fuses (30A)</b>

<b>3</b>	<b>Install the D/C Cut Fuses (30A) (Original Location)</b>
----------	--

#### NOTE

- With the DC CUT FUSE (30A) removed, the diagnostic trouble code (DTC) is detected when the ignition is turned on during transportation. Clear all DTCs using GTS+ after checking that there are no malfunctions on the vehicle.
- While the vehicle is stored at the dealership, disconnect the negative (–) battery terminal to prevent battery discharge. Refer to [L-SB-0016-23 Battery Maintenance During PDS](#) for battery maintenance information.

## 2024 LS 500 and LS 500h Pre-Delivery Service (PDS)

### Front License Plate and Mounting Bracket Installation

The front license plate mounting bracket and two self-tapping screws are stored in the luggage compartment of the vehicle at the assembly plant. For states that require a front license plate, install the bracket and bolts on the bumper cover during PDS according to the following procedure.

1. Align holes "A" of the mounting bracket with the lower set of dimples on the front bumper cover.

**NOTE**

- There are two sets of dimples on the front bumper cover. Use the lower set of dimples.
- Holes "A" are used to install the mounting bracket onto the radiator grille.
- Holes "B" are used to install the front license plate onto the mounting bracket.

2. Install the mounting bracket onto the front bumper cover at holes "A" using the two self-tapping screws.

**Figure 5.**

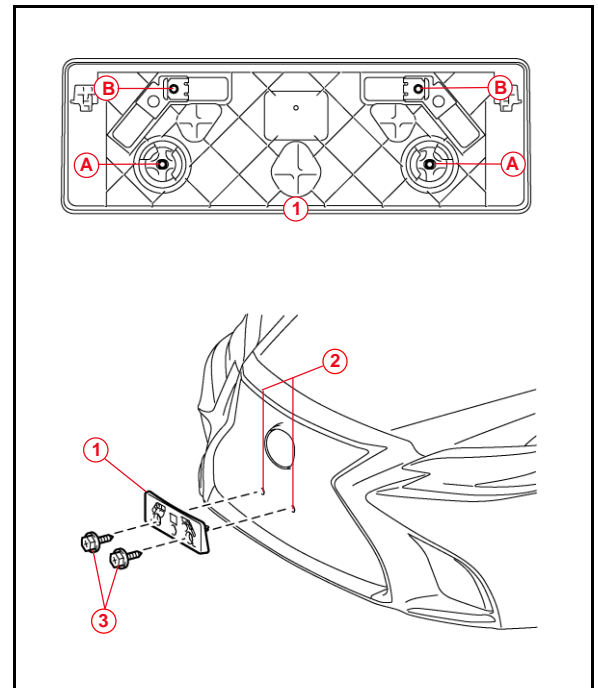

1	Mounting Bracket
2	Lower Dimples
3	Self-tapping Screws

## 2024 LS 500 and LS 500h Pre-Delivery Service (PDS)

---

### Front License Plate and Mounting Bracket Installation (continued)

- Install the front license plate onto the mounting bracket at holes B using two noncorroding bolts with the following dimensions:

**Nominal Length: 15.0 mm (0.59 in.)**

**Diameter: 6.0 mm (0.24 in.)**

**Figure 6.**

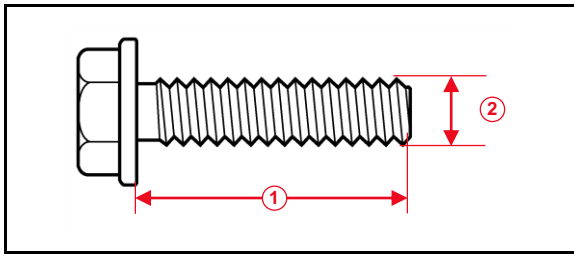

<b>1</b>	<b>Nominal Length</b>
<b>2</b>	<b>Diameter</b>

**Figure 7.**

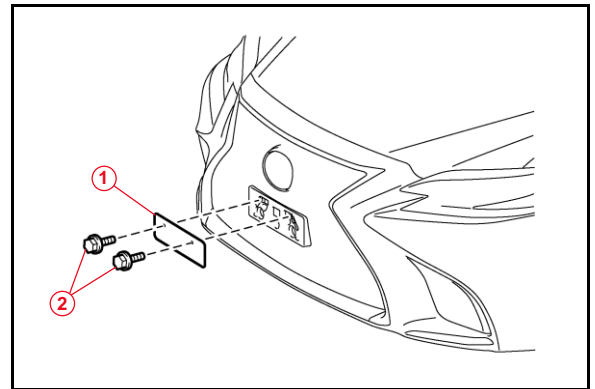

<b>1</b>	<b>Front License Plate</b>
<b>2</b>	<b>Bolts</b>

## 2024 LS 500 and LS 500h Pre-Delivery Service (PDS)

### Front and Rear Emergency Towing Eyelet Removal and Hole Cover Installation

1. Remove the front and rear emergency towing eyelets from the front and rear bumpers by turning them counterclockwise.

**HINT**

If it is difficult to loosen the emergency towing eyelets, use a steel bar.

**Figure 8.**

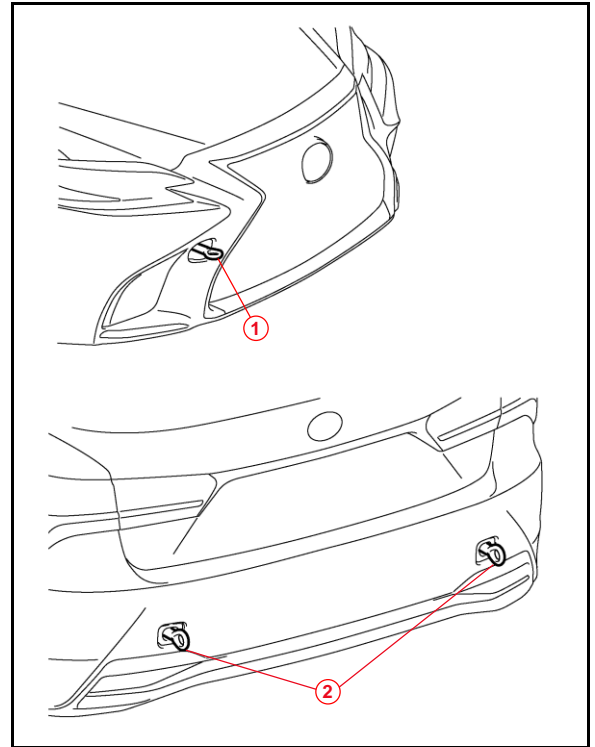

<b>1</b>	<b>Front Emergency Towing Eyelet</b>
<b>2</b>	<b>Rear Emergency Towing Eyelets</b>

2. Place one of the removed emergency towing eyelets into the luggage tray in the luggage compartment.

**HINT**

Dispose of the other removed emergency towing eyelets.

**Figure 9.**

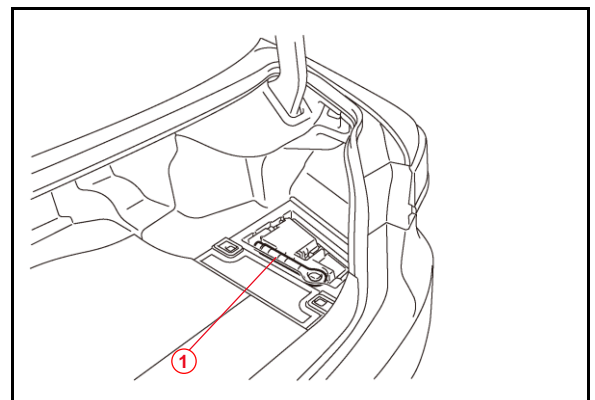

<b>1</b>	<b>Emergency Towing Eyelet</b>
----------	--------------------------------

## 2024 LS 500 and LS 500h Pre-Delivery Service (PDS)

### Front and Rear Emergency Towing Eyelet Removal and Hole Cover Installation (continued)

3. Install the front and rear emergency towing eyelet hole covers, which are stored in the glove compartment, onto the front and rear bumpers.
  - A. Insert the arrow-shaped part of the emergency towing eyelet hole cover "A" into the eyelet hole "B" as shown.
  - B. Install the emergency towing eyelet hole cover to the hole of the bumper.

**HINT**  
 Make sure the front emergency eyelet towing cover is installed in front, and the rear emergency eyelet towing cover is installed in the rear.

**Figure 10.**

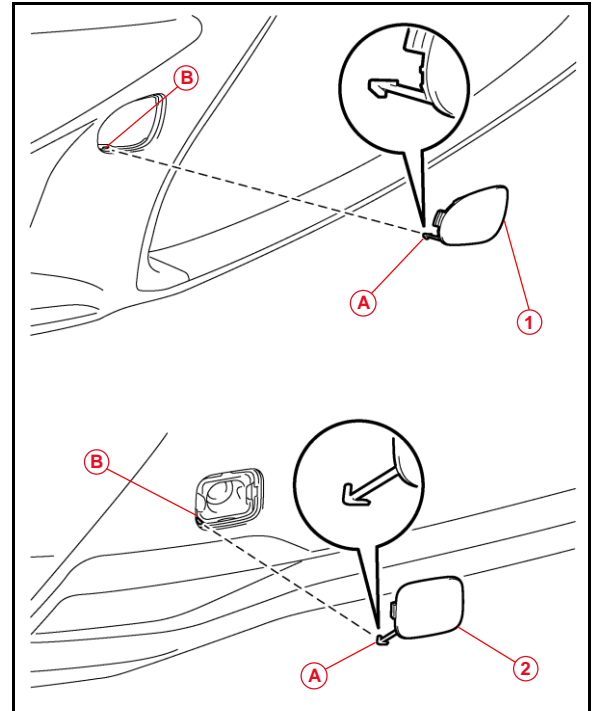

<b>A</b>	<b>Arrow-shaped Part</b>
<b>B</b>	<b>Eyelet Hole</b>
<b>1</b>	<b>Front Emergency Towing Eyelet Hole Cover</b>
<b>2</b>	<b>Rear Emergency Towing Eyelet Hole Cover</b>

## 2024 LS 500 and LS 500h Pre-Delivery Service (PDS)

---

### Front Wheel Opening Extension Pad Installation

The front wheel opening extension pad set (right and left front wheel opening extension pads and four self-tapping screws) is stored in the luggage compartment at the assembly plant to avoid damage in transit.

- Using the distinguishable mark on the pad, hook the retainers of the front left wheel opening extension pad through the installation holes on the fender liner and temporarily fix it to the installation position.

**NOTE**

There is a distinguishable mark on each pad indicating the left and right-side pads.

- Tighten the two self-tapping screws.
- Repeat steps 1 and 2 to install the right front wheel opening extension pad.

**Figure 11.**

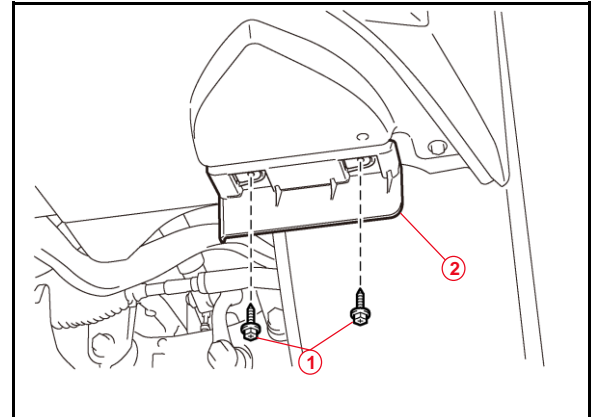

<b>1</b>	<b>Self-tapping Screws</b>
<b>2</b>	<b>Front Wheel Opening Extension Pad</b>

## 2024 LS 500 and LS 500h Pre-Delivery Service (PDS)

### Installation of Rubber Body Plugs

1. Confirm the number of plugs in the glove box. If two plugs are present, perform substep 2A ONLY. If four plugs are present, perform substep 2A AND substep 2B.
2. Install plugs according to the instructions below by confirming the number of plugs in the glove box.
  - A. Install two plugs in the rear side member hole or rocker inner hole as shown.
  - B. Install two plugs in the torque box hole or rocker inner hole as shown.

**Figure 12.**

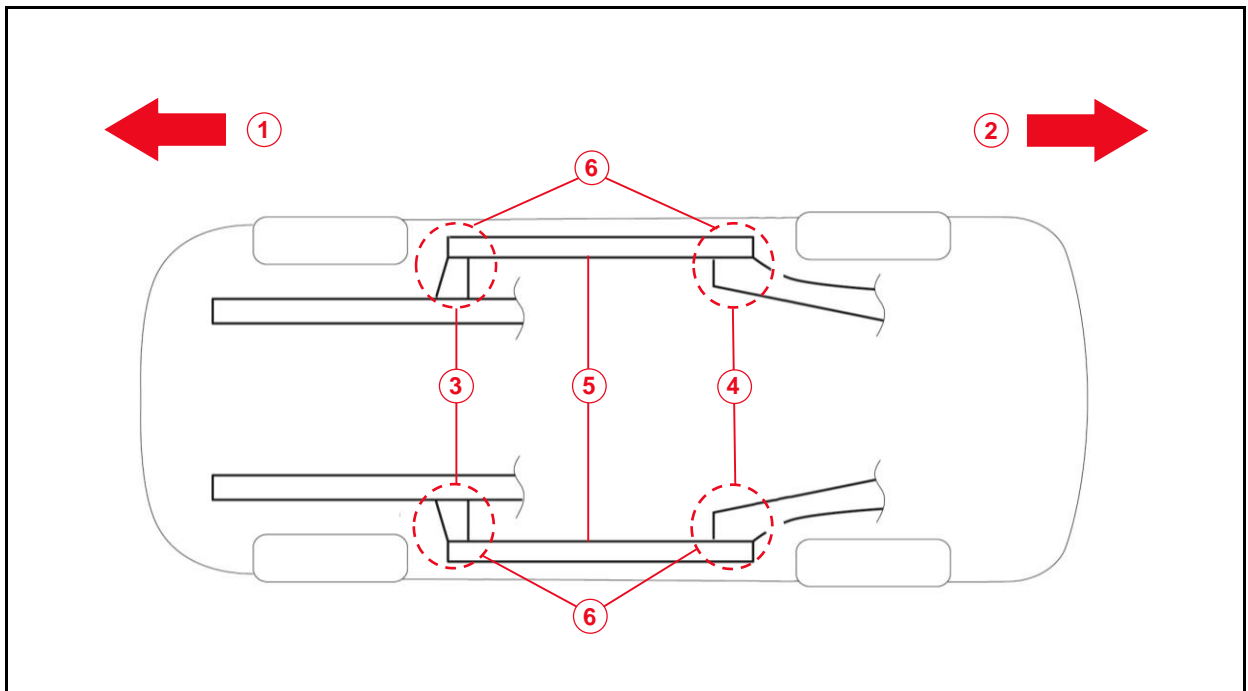

1	Front Side
2	Rear Side
3	Torque Box Hole or Rocker Inner Hole
4	Rear Side Member Hole or Rocker Inner Hole
5	Rocker Inner
6	Install Plug Here (if Applicable)

#### NOTICE

- The installation of these plugs is required to prevent rust.
- These plugs are stored in the glove box.
- The number of plugs may vary according to production locations in the same vehicle model.

## 2024 LS 500 and LS 500h Pre-Delivery Service (PDS)

---

### Tire Pressure Warning System (TPWS) Initialization

Refer to the applicable Repair Manual for the TPWS initialization procedure ([LS 500](#) / [LS 500h](#)).  
Note the spare tire does NOT have a TPWS sensor.

#### NOTE

To adjust the tire pressure correctly when the outside temperature is significantly colder than shop temperature, perform a Health Check using GTS+ and select the compensation tire pressure checkbox. Compensation pressures will display on the Health Check results screen. Adjust the tire pressure when the tires are cold.

### Parking Support Brake System Calibration

As a result of the removal of the D/C cut fuses, the steering angle sensor power source is cut off. When the D/C cut fuses are reinstalled, the center position recognized by the steering angle sensor may not be the appropriate position. Therefore, it is necessary to perform parking support brake system calibration AFTER installing the D/C cut fuses during PDS.

Refer to the applicable Repair Manual for the parking support brake system calibration procedure: ([LS 500](#) / [LS 500h](#)).

## 2024 LS 500 and LS 500h Pre-Delivery Service (PDS)

---

### Memorize Steering Angle Neutral Point

As a result of the removal of the D/C cut fuses, the power source to the steering angle sensor is cut off. When the D/C cut fuses are reinstalled, the parking assist monitor system/panoramic view monitor will be operative, but it cannot display guidelines to assist parking operation because the center position recognized by the steering angle sensor may not be in an initial position. Therefore, perform steering angle neutral point initialization AFTER installing the D/C cut fuses during PDS.

### Hybrid Engine (LS 500h)

1. Start the hybrid system.

#### HINT

When operating the power switch, one short, firm press is enough. It is not necessary to press and hold the switch. If the "READY" indicator illuminates on the Multi-information display, the hybrid system will operate normally.

2. Ensure the panoramic view monitor is operative by placing the shifter in the (R) Reverse position.
3. Check to see if the estimated course lines are displayed.
  - A. If they are not displayed, proceed to steps 4 and 5.
  - B. If they are displayed, Memorize Steering Angle Neutral Point is complete.
4. Shift the shift lever to the "P" position. Turn the steering wheel lock to lock.
5. Shift the shift lever to the "R" position. Check to see if the estimated course lines are displayed.

#### HINT

Initialization of the panoramic view monitor system has been completed when the estimated course lines are displayed.

## 2024 LS 500 and LS 500h Pre-Delivery Service (PDS)

---

### Memorize Steering Angle Neutral Point (continued)

#### Gasoline Engine (LS 500)

1. Start the engine.
2. Ensure the panoramic view monitor is operative by placing the shifter in the (R) Reverse position.
3. Check to see if the estimated course lines are displayed.
  - A. If they are not displayed, proceed to steps 4 and 5.
  - B. If they are displayed, Memorize Steering Angle Neutral Point is complete.
4. Shift the shift lever to the "P" position. Turn the steering wheel lock to lock.
5. Shift the shift lever to the "R" position. Check to see if the estimated course lines are displayed.

#### HINT

Initialization of the panoramic view monitor system has been completed when the estimated course lines are displayed.

### Seating Position Control ECU Initialization

Refer to the applicable Repair Manual for the seating position control ECU initialization procedure ([LS 500](#) / [LS 500h](#)) (procedure 3).

### Rear Door Sunshade Initialization

Initialize the rear door sunshade after installing the D/C cut fuses during PDS.

Refer to the applicable Repair Manual for the rear door sunshade initialization procedure ([LS 500](#) / [LS 500h](#)).

## 2024 LS 500 and LS 500h Pre-Delivery Service (PDS)

---

### Head Unit System Reset

Confirm that the welcome screen with language options appears on the head unit display when the ignition is switched to the ON position. There may be instances where the welcome screen with language options does not properly appear on the head unit display.

If the welcome screen showing language options is NOT displayed, complete the following steps:

1. Select the Settings option (gear icon).
2. Scroll down and select the Info & Security option.
3. The System Reset dialogue box will appear. Select Reset to confirm the resetting of the system.
4. Confirm that the welcome screen with language options is now displayed.

### Dealer Contact Information for Call Dealer Head Unit Function

Refer to the *Multimedia System Owner's Manual* to add dealer contact information. See section 2-8 *Vehicle Settings – Setting Dealer information* ([LS 500](#) / [LS 500h](#)).

### Deletion of Vehicle Alert History

As the D/C cut fuse is removed, the communication between the various ECUs is interrupted. When the D/C fuse is reinstalled, the communication status is restored, but Lexus Enform Service Connect may store malfunction history in the form of vehicle alert history. Therefore, it is necessary to operate the multi-display and delete the vehicle alert history AFTER installing the D/C cut fuses during PDS at the dealership.

1. Turn the engine switch (power switch) to the ON position (ON mode).
2. Push the Menu switch on the remote touch device.
3. On the multi-display, enter the following menus: *Info – Vehicle Alert History*.
4. If there is vehicle alert history stored, perform the Delete History operation.

#### HINT

If there is no vehicle alert history stored, the system will display a message stating "There is no vehicle alert history."

5. When the vehicle alert history deletion confirmation screen is displayed, select "Yes."
6. Turn the engine switch (power switch) to the OFF position (OFF mode).

## 2024 LS 500 and LS 500h Pre-Delivery Service (PDS)

---

### Navigation — Set Date & Time by GPS

Prior to vehicle delivery, it is necessary to turn the Set Date & Time by GPS setting to the ON position.

1. Turn the engine switch (power switch) to the ON position (ON mode).
2. Navigate the following menus in the head unit: *Settings – General – Date & Time – Set date & time by GPS.*
3. Ensure the Set Date & Time by GPS function is set to the ON position.