



# Technical Service Bulletin

---

**55 Hood cannot be opened / released**  
55 23 84 2072188/1 November 22, 2023.

Model(s)	Year	VIN Range	Vehicle-Specific Equipment
Q7, and SQ7	2022 – 2023	All	Not Applicable

## Condition

### Customer states:

- When the hood operating lever is pulled, the hood remains closed or only one of the two hood latches releases/opens.
- The hood cannot be opened.

### Workshop findings:

- The pulling distance of the Bowden cable is too long. The hood latch does not release. Even pulling the operating lever all the way is not sufficient to release the hood latches.

## Technical Background

The functional dimension of the Bowden cable was not adjusted in accordance with a part change of the mounting bracket. Therefore, the pulling distance is not sufficient to release the hood latch.

## Production Solution

Improved parts.

## Service

1. If the pulling distance of the Bowden cable is too long to open the hood, remove the hood operating lever and the lower A-Pillar trim according to: *Elsa>>Repair manual>>Body>>Body Interior>>70 Interior Trim>>Vehicle Interior Trim Panels>>A-Pillar Trim Panel, Removing and Installing>>A-Pillar Lower Trim Panel, Removing and Installing* (Figure 1).



# Technical Service Bulletin

---

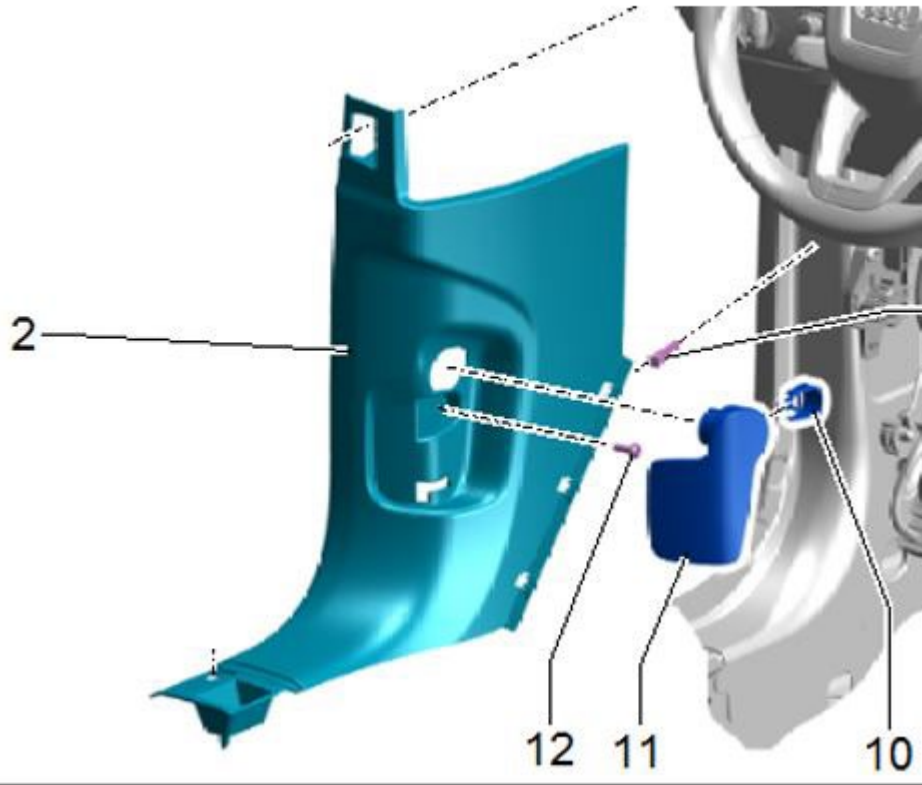

**Figure 1.** Remove the hood operating lever and lower A-pillar trim.

2. Disengage the Bowden cable nipple from the release lever mechanism and use pliers to remove the Bowden cable from the mounting bracket (Figures 2, 3).

Pull the Bowden cable to open the hood.



# Technical Service Bulletin

---

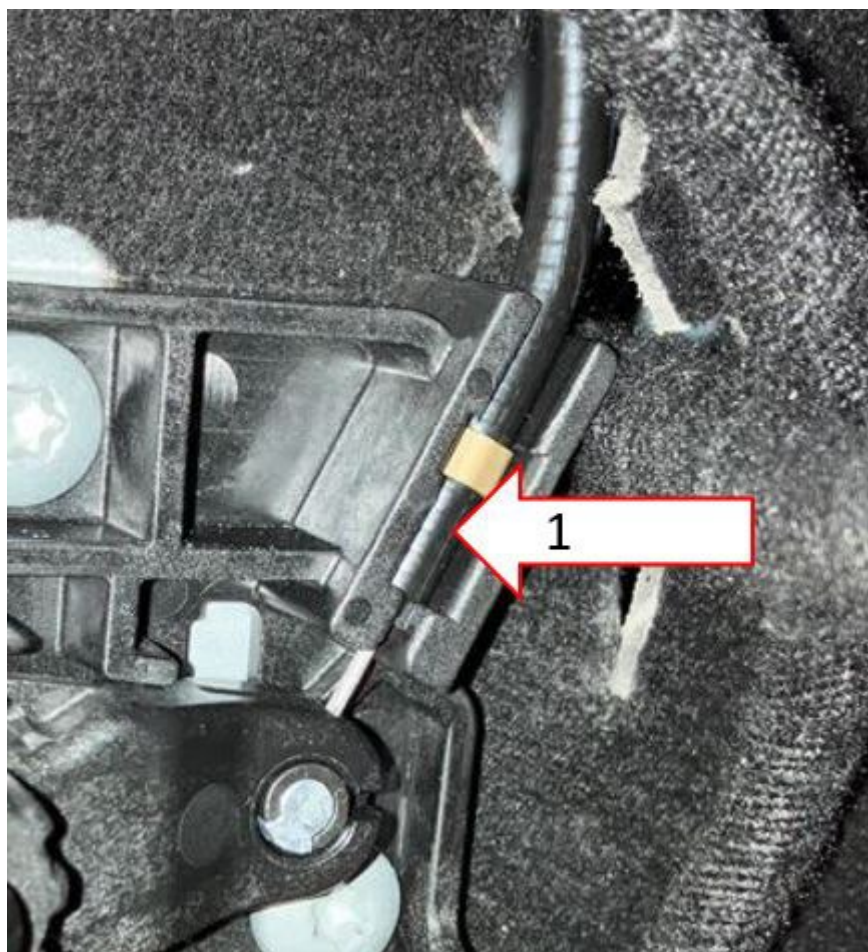

*Figure 2. Remove the Bowden cable from the mounting bracket.*



# Technical Service Bulletin

---



**Figure 3.** Bowden cable removed from mounting bracket.

3. Turn the Bowden cable nipple clockwise 4 times and reinstall it in the lever mechanism in this position (Figures 4, 5). Turning the nipple clockwise will shorten the pulling distance.



# Technical Service Bulletin

---

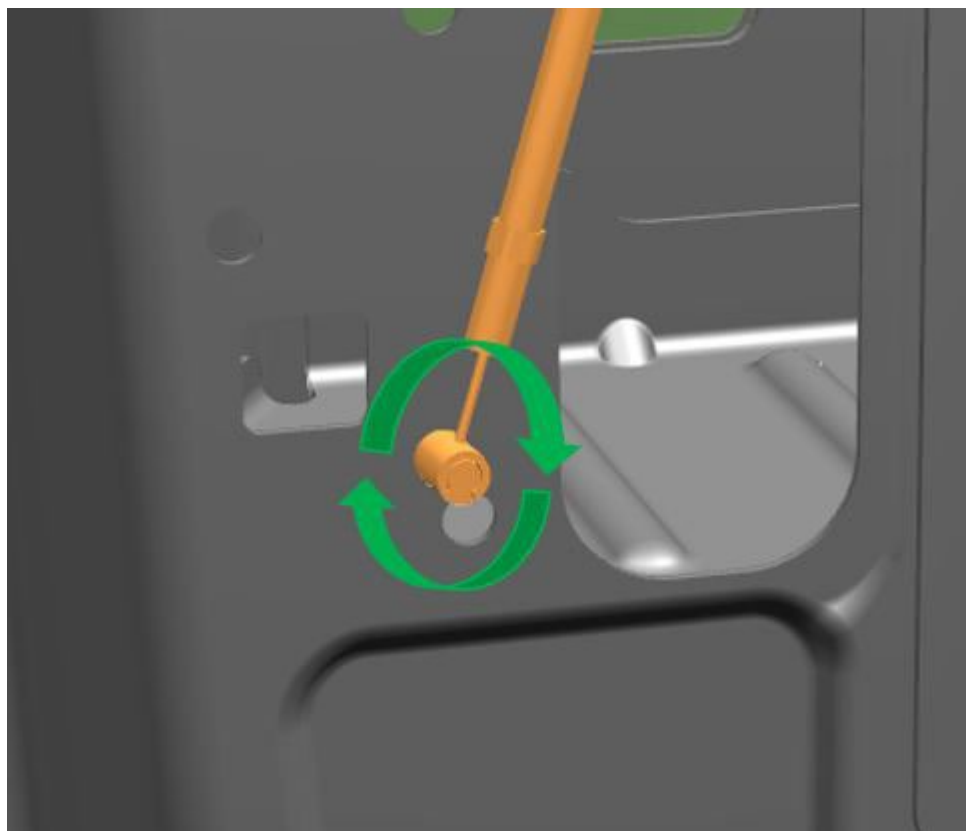

**Figure 4.** Turn the Bowden cable nipple clockwise to shorten the pulling distance.



# Technical Service Bulletin

---



*Figure 5. Reinstall the Bowden cable in the mounting bracket after turning the nipple.*

4. Reinstall the lower A-Pillar trim and the hood operating lever.
5. Check the operation of the hood operating lever. Ensure that both hood latches release.



# Technical Service Bulletin

---

## Warranty

<b>Claim Type:</b>	<ul style="list-style-type: none"><li>• 110 Up to 48 Months/50,000 Miles.</li><li>• G10 for CPO Covered Vehicles – Verify Owner.</li><li>• If the vehicle is outside of any warranty, this Technical Service Bulletin is informational only.</li></ul>		
<b>Service Number:</b>	5514		
<b>Damage Code:</b>	0016		
<b>Labor Operations:</b>	A-pillar trim remove+reinstall	7057 1905	See SRT with associated operations
	Adjust hood latch release cable	5514 4999	10 TU
<b>Diagnostic Time:</b>	GFF	No allowance	0 TU
	Road test prior to the service procedure	No allowance	0 TU
	Road test after the service procedure	No allowance	0 TU
<b>Claim Comment:</b>	As per TSB 2072188/1		

All warranty claims submitted for payment must be in accordance with the *Audi Warranty Policies and Procedures Manual*. Claims are subject to review or audit by Audi Warranty.

## Additional Information

All part and service references provided in this TSB (**2072188**) are subject to change and/or removal. Always check with your Parts Department and/or ETKA for the latest information and parts bulletins. Please check the Repair Manual for fasteners, bolts, nuts, and screws that require replacement during the repair.

©2023 Audi of America, Inc. All rights reserved. The information contained in this document is based on the latest information available at the time of printing and is subject to the copyright and other intellectual property rights of Audi of America, Inc., its affiliated companies, and its licensors. All rights are reserved to make changes at any time without notice. No part of this document may be reproduced, stored in a retrieval system, or transmitted in any form or by any means, electronic, mechanical, photocopying, recording, or otherwise, nor may these materials be modified or reposted to other sites without the prior expressed written permission of the publisher.