

# Technical product information

<b>Topic</b>	Repeated traction control interventions experienced upon reaching 30km/h
<b>Market area</b>	Australia E04 Bentley rest Asia and Australia (6E04),China 723 Volkswagen (Anhui) Automotive CO (6723),China 796 VW Import Comp. Ltd (Vico), Beijing (6796),Germany E02 Bentley rest Europe (6E02),Japan E03 Bentley Japan (6E03),Korea, (South) E08 Bentley South Korea (6E08),United Arab Emirates E06 Bentley Middle East and Africa (6E06),United Kingdom E01 Bentley UK (6E01),United States E05 Bentley USA and rest America (6E05)
<b>Brand</b>	Bentley
<b>Transaction No.</b>	2067579/3
<b>Level</b>	EH
<b>Status</b>	Released for publishing
<b>Release date</b>	28-Sep-2023

## New customer code

Object of complaint	Complaint type	Position
running gear -> brakes, brake control -> traction control system (TCS)	functionality -> without function / defect	

# Vehicle data

## New Continental GT(C) and New Flying Spur

### Sales types

Type	MY	Brand	Designation	Engine code	Gearbox code	Final drive code
3S3*	2018	E		*	*	*
3S3*	2019	E		*	*	*
3S3*	2020	E		*	*	*
3S3*	2021	E		*	*	*
3S3*	2022	E		*	*	*
3S3*	2023	E		*	*	*
3S3*	2024	E		*	*	*
3S4*	2019	E		*	*	*
3S4*	2020	E		*	*	*
3S4*	2021	E		*	*	*
3S4*	2022	E		*	*	*
3S4*	2023	E		*	*	*
3S4*	2024	E		*	*	*
ZG2*	2020	E		*	*	*
ZG2*	2021	E		*	*	*
ZG2*	2022	E		*	*	*
ZG2*	2023	E		*	*	*
ZG2*	2024	E		*	*	*

# Documents

Document name
<a href="#">master.xml</a>

### Customer statement / workshop findings

Repeated traction control interventions experienced upon reaching 30km/h (Figure 1)

HINT: Refer to the video which has been uploaded onto the Bentley Hub reference Video 1 for TPI 2057579



Figure 1

### Technical background

In the event the issue is as exactly as described, refer to the instructions within the Measure section

### Production change

Not applicable

### Measure



#### VERY IMPORTANT:

1) Confirm the tyre pressures (all tyres) are to Bentley specification

- Check to confirm the wheel and tyres assemblies are Bentley approved (same specification parts as per the original factory build

Or

approved Bentley accessory wheels and tyres are fitted

- Confirm the 'B' marking is evident on all tyres (Figure 2)

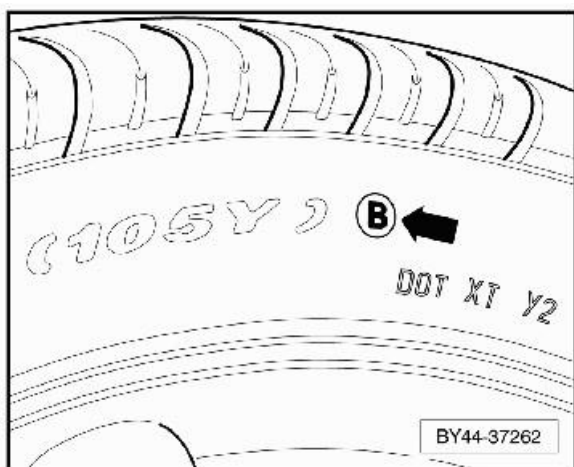

Figure 2

2) In the event the issue is evident following a tyre and/or wheel change, perform an inspection of the relevant vehicle corner, check each of the following sensors for contamination damage etc

- Upright acceleration sensor
- ABS wheel speed sensor
- Referring to the applicable wiring diagram - Conduct a wiring integrity check of each sensor and check all associated wiring harnesses/connectors etc for damage

3) In the event the wheels and tyres and sensor/wiring checks are within specification - Check the applicable vehicle corner wheel bearing for any noise, excess movement or contamination

4) With the aid of a second operative, perform a road test to monitor the following measured values

HINT: Refer to the video which has been uploaded onto the Bentley Hub reference Video 2 for TPI 2057579



### DO NOT UNDER ANY CIRCUMSTANCES PERFORM THIS OPERATION WITHOUT A SECOND OPERATIVE

- Record a video showing live values (see example in Figure 3 of the values which should be monitored) whilst the fault is present

TIP: Save a copy of the video

[IDE02538]_Longitude acceleration sensor			
[IDE02311]_Left front wheel speed sensor installation position			
[IDE02312]_Right front wheel speed sensor installation position			
[IDE02313]_Left rear wheel speed sensor installation position			
[IDE02314]_Right rear wheel speed sensor installation position			
[IDE02315]_Direction of rotation front left wheel speed sensor			
[IDE02316]_Direction of rotation front right wheel speed sensor			
[IDE02317]_Direction of rotation rear left wheel speed sensor			
[IDE02318]_Direction of rotation rear right wheel speed sensor			
[IDE09389]_Steering angle sensor			
[IDE00326]_Steering wheel angle			
[IDE00920]_Front left wheel speed			
[IDE00921]_Wheel speed, right front			
[IDE00922]_Left rear wheel speed			
[IDE00923]_Right rear wheel speed			

Figure 3

5) Conduct a second road test (Reference Manoeuvres road test below) as per the instructions below, the operative MUST confirm if the fault remains during the second road test (Manoeuvres)

#### **Manoeuvres road test**

With appropriate space and ensuring all speed restrictions are adhered to, conduct the following where safe to do so:

- 1) Switch off the engine and lock the vehicle for 10 minutes
- 2) Unlock the vehicle
- 3) Switch ON the ignition and start the engine
  - Select Bentley mode and select Drive (D)
- 4) Whilst attempting not to induce a traction control intervention, drive the car in a straight line for approximately 10 seconds at a minimum of 50kph
  - Reset the traction control by lifting off the accelerator, allow the vehicle to come to a gradual rest (where safe to do so)
  - Switch off the engine
- 5) Switch ON the ignition and start the engine
  - Select Bentley mode and select Drive (D)
- 6) As per normal customer usage, **drive off in a straight line only** ensuring the following separate throttle inputs (**a to c**) until either the 30kph intervention event or approximately 50kph (ensuring all speed limits are adhered to)
  - a) Apply enough throttle input to smoothly manoeuvre off from stand still at a rate of approximately 5kph/second  
Reset the traction control by lifting off the accelerator, allow the vehicle to come to a gradual rest (where safe to do so)
  - b) Apply enough throttle input to smoothly manoeuvre off from stand still at a rate of approximately 10kph/second  
Reset the traction control by lifting off the accelerator, allow the vehicle to come to a gradual rest (where safe to do so)
  - c) In swift succession, smoothly manoeuvre off from stand still at a rate of approximately 10kph/second and lift of the throttle if traction control intervention occurs, then swiftly reapply throttle as per the previous 10kph/second input

Reset the traction control by lifting off the accelerator, allow the vehicle to come to a gradual rest (where safe to do so)

After conducting points **a to c** Is the traction control intervention still present?

**Comments**

7) Switch OFF the ignition and stop the engine

- Apply the steering lock

8) Switch ON the ignition and start the engine

- Select Bentley mode and select Drive (D)

9) As per normal customer usage, **drive off ensuring the vehicle is driven via junction exits and performing small radius cornering** ensuring the following separate throttle inputs are conducted (**d to f**) until either the 30kph intervention event is evident or approximately 50kph is achieved

**d)** Apply enough throttle to smoothly manoeuvre off from stand still at a rate of approximately 5kph/second

Reset the traction control by lifting off the accelerator, allow the vehicle to come to a gradual rest (where safe to do so)

**e)** Apply enough throttle input to smoothly manoeuvre off from stand still at a rate of approximately 10kph/second

Reset the traction control by lifting off the accelerator, allow the vehicle to come to a gradual rest (where safe to do so)

**f)** In swift succession, smoothly manoeuvre off from stand still at a rate of approximately 10kph/second and lift of the throttle if intervention occurs, then swiftly reapply throttle as previous 10kph/second input

Reset the traction control by lifting off the accelerator, allow the vehicle to come to a gradual rest (where safe to do so)

After conducting points **d to f** Is the traction control intervention still present?

**Comments**

On completion of the Manoeuvres, conduct the following:

10) With the ignition off - Referring to Rep.Gr 45 - disconnect the electrical connection from the ESC unit -J104 and wait 10 seconds - Reconnect the electrical connection

- Erase all applicable DTC's in particular any DTC's relating to 03 Brakes
- Perform a subsequent road test recording the same values as (Figure 3) to establish if issue has been rectified.



**VERY IMPORTANT: If fault is still evident remains present - Open a new DISS query or respond via the already open query, ensuring all previously requested information is clearly attached, DO NOT conduct any further repair work until permission is granted from Product Support**

- Provide clear information regarding when the fault occurs, For example after engine start, up to a speed of 28 km/h



**In the event that Product support grant permission to replace ESC unit - J104 via the open DISS query**

**The operative must ensure the manoeuvres road test is repeated after ESC unit - J104 renewal to confirm the resolution of the concern**

## Warranty accounting instructions

Warranty type 110 or 910  
Service number 45 30  
Damage code 00 40

### Time to conduct initial diagnosis

Labour operation code 45 30 01 00 (Use 99 index until 29/9/22)  
Time 50 TU's

### Time to replace the ESC unit - J104 - New Flying Spur

Labour operation code 45 30 55 50  
Time 10 TU's

### Time to remove and install the ESC unit - J104 - New Flying Spur

Labour operation code 45 30 19 10  
Time 140 TU's

### Time to code the new ESC unit - J104 - to the vehicle New continental GT/C (All M/Y)

Labour operation code 01 50 00 00  
Time 10 TU's

### Time to remove and install the ESC unit - J104 - New continental GT/C (18 M/Y)

Labour operation code 45 30 19 00  
Time 270 TU's

### Time to remove and install the ESC unit - J104 - New continental GT/C (19 M/Y onwards)

Labour operation code 45 30 19 10  
Time 140 TU's

### Road test

Labour operation code 01 21 00 00  
Time 50 TU's (Maximum of two road tests)

## Parts information

Refer to the ETKA parts catalogue



**NOTE:** Permission must be given by Product Support via the open DISS query before ESC unit - J104 is replaced