

ENGINE COOLING FAN EXCESSIVE NOISE WHEN PLUG IN CHARGER IN USE

Range Rover

- 23-24MY Range Rover – PHEV ONLY
- 23-24MY Range Rover Sport – PHEV ONLY

Customer Voice:

- Customer reports that the engine cooling fan operation is excessively noisy in operation for an extended period of time when the vehicle is being charged using a low output plug in home charger.

Technical Description:

- Heating Ventilation Air Conditioning (HVAC) software requires an update.

Status:

- Please follow the Diagnostic tool operation to update the HVAC module.

Refer to SSM 76080

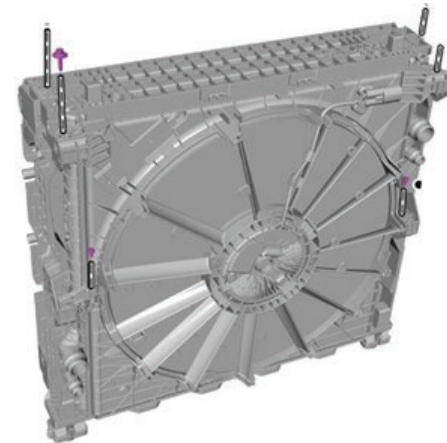

E307408