

| | |
|---|-------------------------------------|
| Subject: WATER LEAK BETWEEN DOORS AT B-PILLAR | Service Alert No.: SA-068/23 |
| | Last Issued : 10/19/2023 |

BULLETIN NOTES

APPLICABLE MODEL(S)/VINS:

2019-2024 Mazda3 (Japan and Mexico Built)

DESCRIPTION

Some vehicles may have a water leak and/or a technician may find water inside the cabin or within a component. The source of the leak may be from between the doors at the B-pillar. To correct this concern, there was a mass production change (MPC) on January 14, 2021 to reduce the gap (as seen in the image below).

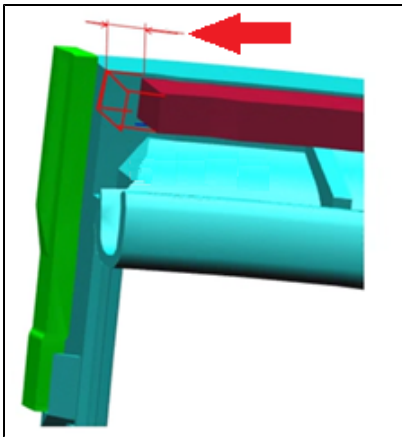

CONSUMER NOTICE: The information and instructions in this bulletin are intended for use by skilled technicians. Mazda technicians utilize the proper tools/ equipment and take training to correctly and safely maintain Mazda vehicles. These instructions should not be performed by "do-it-yourselfers." Customers should not assume this bulletin applies to their vehicle or that their vehicle will develop the described concern. To determine if the information applies, customers should contact their nearest authorized Mazda dealership. Mazda North American Operations reserves the right to alter the specifications and contents of this bulletin without obligation or advance notice. All rights reserved. No part of this bulletin may be reproduced in any form or by any means, electronic or mechanical---including photocopying and recording and the use of any kind of information storage and retrieval system ---without permission in writing.

REPAIR PROCEDURE

1. Verify the customer concern.
2. Is the water leak from the area shown in the image below?

YES - Continue to the next step .

NO - This Service Alert does not apply.



3. Was the vehicle produced before January 14, 2021?

YES - Replace both front and rear door seals and retest for a leak.

NO - Diagnose the vehicle and repair it using other information found on MGSS.

4. Verify the repair.

CONSUMER NOTICE: The information and instructions in this bulletin are intended for use by skilled technicians. Mazda technicians utilize the proper tools/ equipment and take training to correctly and safely maintain Mazda vehicles. These instructions should not be performed by "do-it-yourselfers." Customers should not assume this bulletin applies to their vehicle or that their vehicle will develop the described concern. To determine if the information applies, customers should contact their nearest authorized Mazda dealership. Mazda North American Operations reserves the right to alter the specifications and contents of this bulletin without obligation or advance notice. All rights reserved. No part of this bulletin may be reproduced in any form or by any means, electronic or mechanical---including photocopying and recording and the use of any kind of information storage and retrieval system ---without permission in writing.