

Technical product information

Topic	New Continental GT and New Continental GTC
Market area	Australia E04 Bentley rest Asia and Australia (6E04),China 723 Volkswagen (Anhui) Automotive CO (6723),China 796 VW Import Comp. Ltd (Vico), Beijing (6796),Germany E02 Bentley rest Europe (6E02),Japan E03 Bentley Japan (6E03),Korea, (South) E08 Bentley South Korea (6E08),United Arab Emirates E06 Bentley Middle East and Africa (6E06),United Kingdom E01 Bentley UK (6E01),United States E05 Bentley USA and rest America (6E05)
Brand	Bentley
Transaction No.	2071050/2
Level	EH
Status	Approval
Release date	

New customer code

Object of complaint	Complaint type	Position
electrical power, electric system, data transfer -> power supply	functionality	
lighting system, signalling -> exterior illumination -> main lights	functionality -> partially without function	> not specified <
lighting system, signalling -> exterior illumination -> main lights	functionality -> uneven	> not specified <

Vehicle data

New Continental GT and New Continental GTC

Sales types

Type	MY	Brand	Designation	Engine code	Gearbox code	Final drive code
3S3*	2018	E		*	*	*
3S3*	2019	E		*	*	*
3S3*	2020	E		*	*	*
3S3*	2021	E		*	*	*
3S3*	2022	E		*	*	*
3S3*	2023	E		*	*	*
3S4*	2019	E		*	*	*
3S4*	2020	E		*	*	*
3S4*	2021	E		*	*	*
3S4*	2022	E		*	*	*
3S4*	2023	E		*	*	*

Documents

Document name
master.xml

Customer statement / workshop findings

Customer Complaint:

Headlamp low beam/high beam malfunction

Or

Headlamp - Daytime running light (DRL), position light or direction indicator malfunction

Workshop finding:

Headlamp assembly diagnosed as faulty

Technical background

WARNING

Vehicles using a High voltage system MUST only be worked on by suitably qualified personnel



It is not possible to determine between internal lamp defects and control unit failures therefore this TPI is to advise the replacement of the headlamp control unit(s) in the first instance

The complete headlamp assembly should only be replaced if replacement of the control unit(s) was not successful

Depending on the symptom the following should be conducted:

- Head lamp low beam or high beam malfunction - Refer to Scenario 1 - Replace the headlamp rear control unit
- Head lamp (DRL), position light or direction indicator malfunction - Refer to Scenario 2 - Replace the headlamp side control unit
- Should both issues be evident please conduct the instructions as detailed in Scenarios 1 and 2

NOTICE

Please ensure that all VIN and symptom related TPI's are conducted before continuing with the instructions in the Measure section particularly TPI 2054599/-

Production change

Not applicable

Measure

Scenario 1 - Headlamp rear control unit replacement

NOTICE

IMPORTANT NOTICE: Please ensure that photographs showing the issues found whilst conducting this TPI are attached to a new or existing DISS query as detailed below:

- Photographs showing the actual failure mode
- Photographs after the repair has been successfully completed
- Failure to provide the required information could result in warranty claims being cancelled

Hint: In the event the issue was still evident after the control unit was replaced and a new headlamp assembly was required to resolve the issue, a photograph of the failure mode after the control unit was initially replaced is also required

CAUTION

Have the checks within TPI 2054599/- been conducted?

Yes - Carry out the remaining instructions from step 1

No - Conduct TPI 2054599/-

- 1) Referring to Rep.Gr 94 - Remove the applicable headlamp
- 2) Replace the rear headlamp control unit as follows:

- Referring to Figure 1 - Using an external torx socket - Remove (x3) fixings (1.5) Nm and carefully extract the control unit (1) to gain access to the harness connector (2)

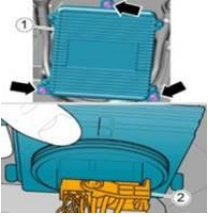

Figure 1

- Referring to Figure 2 - Press the catch (1) in the direction of the arrow, at the same time rotate the harness plug retainer (2) outwards as shown to allow the harness plug to be disconnected

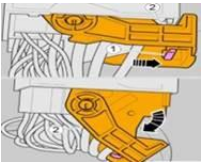

Figure 2

- Referring to Figure 3 - Installation is the reverse of the removal procedure, pay attention to the seal (1) ensuring there is NO damage
- Ensure the seal is seated correctly as shown

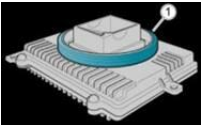

Figure 3

- Referring to Figure 4 - Connect the harness connector (1) and fully close the retainer (2) when correct retention of the harness connector is achieved, an audible click will be heard



Figure 4

- Referring to Figure 5 - Insert the new control unit (1) into the headlamp assembly aperture (highlighted) - Take care not to dislodge the control unit seal (2)

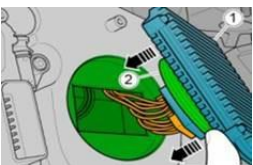

Figure 5

- Referring to Figure 6 - Press the control unit into the headlamp assembly evenly, then insert the three fixings -arrows- using the external torx socket - Torque tighten to (1.5) Nm - Connect the headlamp assembly connector



Figure 6

- Apply a yellow paint line as shown in Figure 7

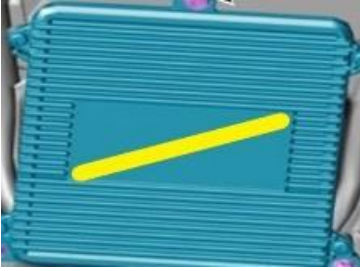

Figure 7

3) Run the headlamp replace test with the diagnostic tester as detailed within the guided functions test

- Check the operation of the headlamp
- Does the headlamp operate to specification?

YES:

- Referring to Rep.Gr 94 - Refit the headlamp
- Where applicable calibrate the matrix headlamps

NO:

- In the event the issue is not resolved the operative must replace the complete headlamp assembly as detailed within Rep.Gr 94

Scenario 2 - DRL control unit replacement

<p>⚠ CAUTION</p>
<p>Have the checks within TPI 2054599/- been conducted?</p>

Yes - Carry out the remaining instructions from step 1

No - Conduct TPI 2054599/-

- 1) Referring to Rep.Gr 94 - Remove the applicable headlamp
- 2) Replace the side headlamp control unit as follows:

- Referring to Figure 8 - Using an external torx socket - Remove the three fixings (1.5 Nm) - Carefully extract the side control unit (1)

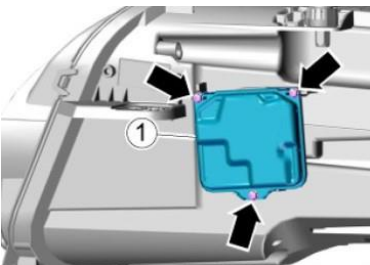

Figure 8

- Referring to Figure 9 - Carefully withdraw the control unit (1) away from the harness connector (2)

Hint: The harness connector (2) is secured to the headlamp assembly - NOT the control unit (1)

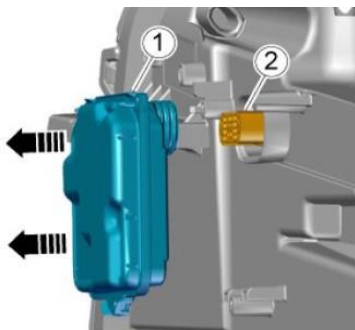

Figure 9

- Referring to Figure 10 - Installation is the reverse of the removal procedure, pay attention to the seal (1) ensuring there is NO damage
- Ensure the seal is seated correctly as shown



Figure 10

- Referring to Figure 11 - Carefully insert the control unit (1) back into the headlamp assembly, ensuring that it is fitted evenly into the harness connector (2)



Figure 11

- Referring to Figure 12 - Press the control unit into the headlamp assembly evenly, then insert the fixings -arrows- using the External torx socket - Torque tighten to (1.5) Nm - Connect the headlamp assembly connector

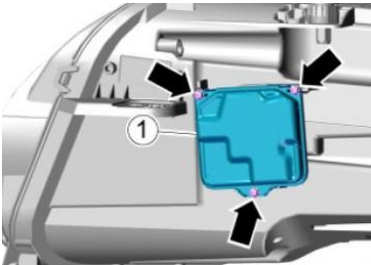

Figure 12

- Apply a yellow paint completion line as shown in Figure 13



Figure 13

3) Run the headlamp replace test with the diagnostic tester in the guided functions test

- Check the operation of the headlamp
- Does the headlamp operate to specification?

YES:

- Referring to Rep.Gr 94 - Refit the headlamp
- Where applicable calibrate the matrix headlamps

NO:

- In the event the issue is not resolved the operative must replace the complete headlamp assembly as detailed within Rep.Gr 94

Warranty accounting instructions

NOTICE

IMPORTANT NOTICE: Please ensure that photographs showing the issues found whilst conducting this TPI are attached to a new or existing DISS query as below.

- **Photographs showing the actual failure mode**
- **Photographs after the repair has been successfully completed**
- **Failure to provide the required information could result in warranty claims being cancelled**

Hint: In the event the issue was still evident after the control unit was replaced and a new headlamp assembly was required to resolve the issue, a photograph of the failure mode after the control unit was initially replaced is also required

Warranty type 110 or 910

Damage service number 94 18 - Control unit

Damage service number 94 15 - Headlamp assembly

Damage code 00 40

Time to replace the headlamp rear control unit (headlamp removed) and test the functionality of the headlamp

Labour operation code 94 10 19 50

Time 10 TU

Time to replace the side control unit (headlamp removed) and test the functionality of the headlamp

Labour operation code 94 10 19 53

Time 10 TU

Time to remove and refit the headlamp

Labour operation code 94 15 19 00

Time 260 TU

Time to align both headlamps

Labour operation code 94 15 16 00

Time 20 Time units

Diagnosis time

Labour operation code 01 50 00 00

Time As per ODIS log Must not exceed 20 Time units

Parts information

Rear control unit - 7PP 941 592A (x1)

Side control unit - 80A 907 397D (x1)

 CAUTION

The part numbers listed can change without notice, please refer to the ETKA parts catalogue to ensure the latest specification part(s) are ordered/supplied