



Electronic Pressure Relief Valve (EPRV) Delete & Fuel Rail Pressure Sensor Update

Service Category Service Department

Section Function Group 237

Technician Skill Level A

Market North America

Applicability

Mack

Model Years	Models
2018 - 2019	AN, CHU, CXU, GR, GI, PI MRU, LR, TE

Introduction

Mack Trucks has identified through Remote Diagnostics that the vehicles in this Service Campaign have experienced faults with the Electronic Pressure Relief Valve (EPRV). To address this issue, follow the repair outlined within this bulletin to remove the EPRV, Update the Fuel Rail Pressure Sensor (FRPS) and wiring harness, followed by running an accessory kit to reprogram the vehicle.

Production Change Information

This bulletin applies to vehicles built within the specified production changes below.

Brand	Engine	Emission Level	Starting Build Date	Ending Build Date
Mack	MP7, MP8	EM-USA17 OBDEP-A & OBDEP-B	14-November-2016	20-December-2018

Warranty Information

This repair may be eligible for reimbursement if a product failure was experienced with in time and mileage limits of the applicable Warranty coverage. Reimbursement is obtained via the normal claim handling process.		
Claim Type (used only when uploading from the Dealer Bus. Sys.)		B
Labor Code	Description	Hours
2373-01-09-01 (Main)	Valve, common rail remove	0.6 hrs
1700-22-03-06	Accessory Kit, programming	0.1 hrs
2841-22-02-01	ECM and ACM, Reprogramming	0.4 hrs
2115-03-02-02	Valve Cover, Replacement	Use Impact Time (0.9 - 1.9 hr.)
If Applicable		
2373-03-03-06	Pressure Sensor, Common Rail, Replacement, Valve Cover Removed	0.2 hrs
2861-03-03-03	Wiring Harness, Injector, Replacement (Rear), Valve Cover removed	Use Impact Time (0.3-0.4 hrs)
Causal Part	22720232	
SCC Authorization Code	S7567	

EPRV Delete & FRPS Update

Expiration Date

December 31, 2024

Parts Information

Special Order Information if applicable

Configuration	Part Numbers	Part Names	Quantity
All	85156544	EPRV delete kit	1
If Applicable Parts(Reference Step 18)			
13L Engine Only	23488939	Pressure Sensor, F2 Common Rail	1
13L Engine Only	23502054	Wiring Harness, Rear	1
11L Engine Only	23488937	Pressure Sensor, F2 Common Rail	1
11L Engine Only	23502057	Wiring Harness, Rear	1

Required Tools & Equipment

- Premium Tech Tool (PTT) with latest version
- 88800634 - Wrench

Calibration Information

- Accessory Kit: **85156014**

Repair Procedure

1. Refer to IMPACT document ID: 2115-03-02-02 Valve Cover, Replacement for valve cover removal procedure.
2. Loosen the cap nuts
3. Remove and discard the pipe.

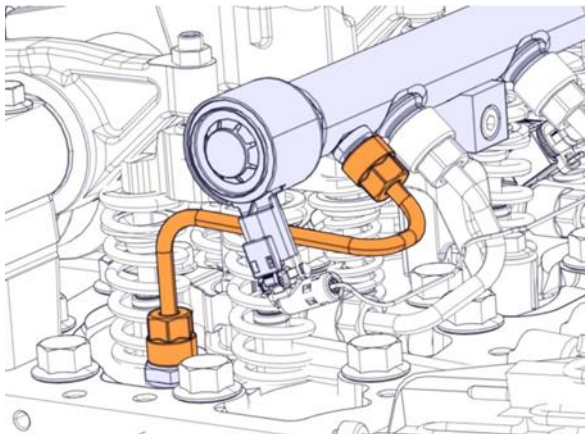

4. Disconnect the connector.

EPRV Delete & FRPS Update

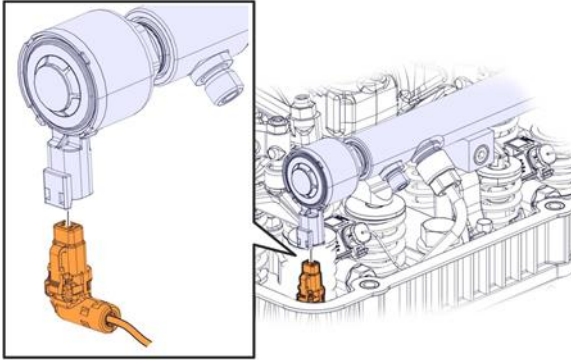

5. Clean the area around the fitting.
6. Remove the fitting and seal.

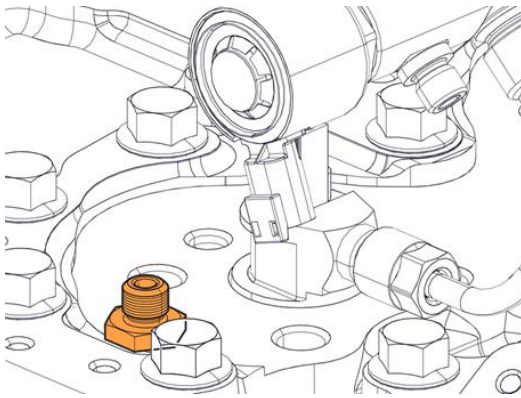

7. Install the seal and plug in the cylinder head.

Tightening torque	
Cylinder head, plug	36± 6 lbf-ft. (50 ± 8 Nm)

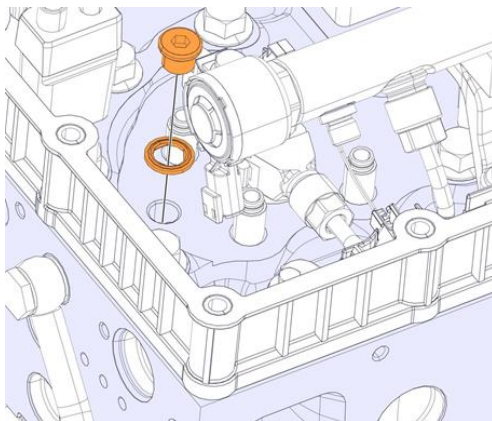

8. Install the tool. 88800634
9. Remove the valve.

Note: Use a spanner as a counter hold to prevent the common rail brackets and pressure pipes from being loaded during component removal and installation.

EPRV Delete & FRPS Update

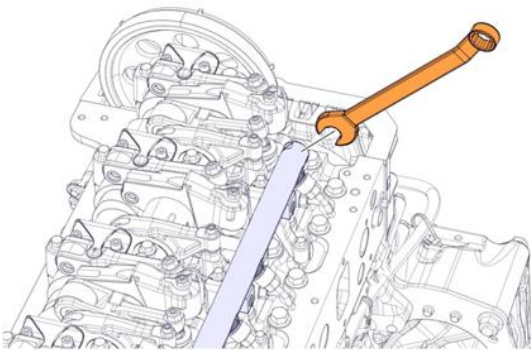
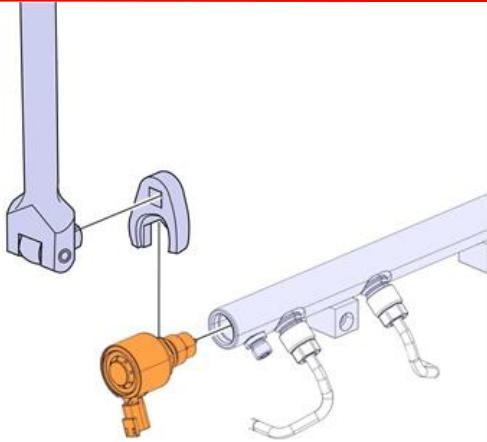

CAUTION

Risk of personal injury.
Loose particles can spatter up and injure the eyes. Work with compressed air can cause hearing impairment.
Always wear safety goggles and hearing protection when working with compressed air.

10. Install the protecting plug.

Required material	
Protecting plug	88800527

11. Clean the threads.

Note: Leave the protecting plug in place until installing the common rail plug.

EPRV Delete & FRPS Update

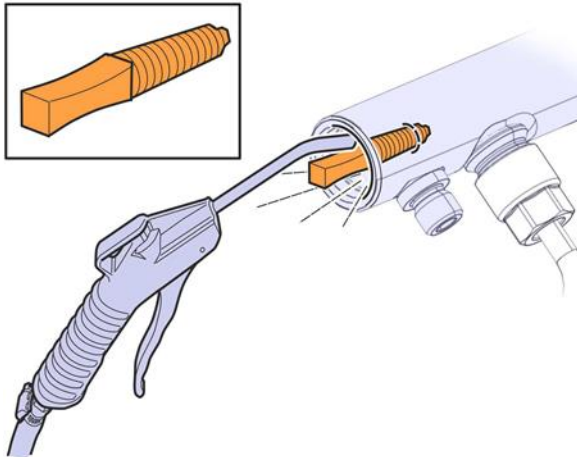

12. Remove the protecting plug.
13. Install the plug in the rail.
Note: Do not use locking fluid or thread sealant
14. Torque tighten the plug.

Tightening torque	
Common rail, plug	92± 7 lbf-ft. (125 ± 10 Nm)

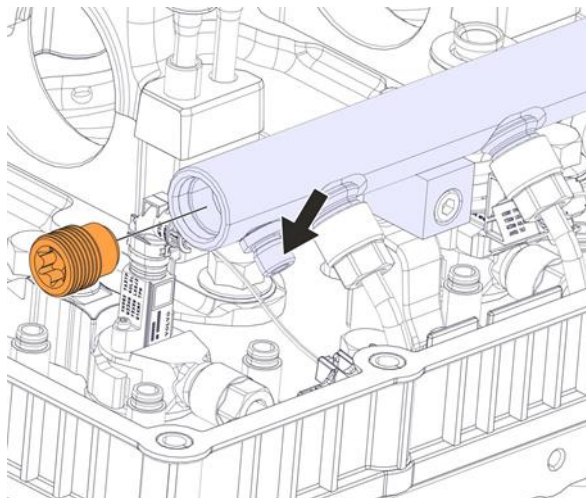

Note: Cap is not required to seal the common rail where the drainpipe connected.

EPRV Delete & FRPS Update

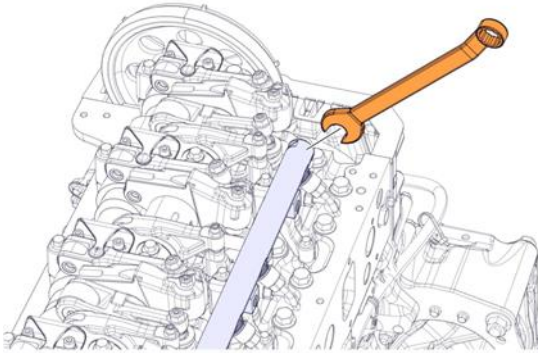

Note: Use a spanner as a counter hold to prevent the common rail brackets and pressure pipes from being loaded during component removal and installation

- 15. Cut the harness.
- 16. Remove connector and harness.

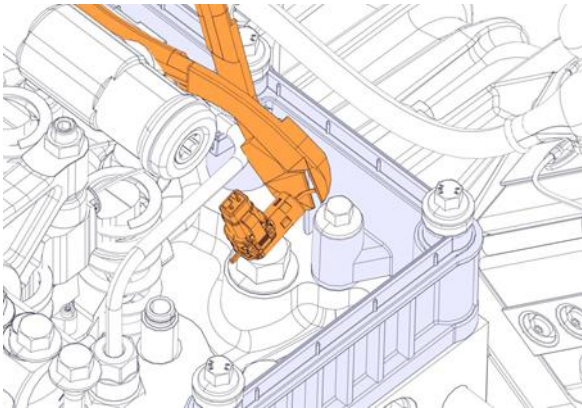

Note: Do not tape or seal the end of the harness

- 17. A product improvement has been made to the Fuel Pressure Sensor (FRPS) and its wiring harness. A visual inspection of the FRPS electrical connector will indicate which sensor and wiring harness is on the vehicle.



EPRV Delete & FRPS Update

18. Inspect the FRPS, if the old-style connector is found (Displayed above with red X), replace the sensor and wiring harness per Impact Instructions listed below. If the new improved connector is found, no farther action is needed and proceed to next step.
 - a. 2373-03-03-06 Pressure Sensor, Common Rail, Replacement, Valve Cover Removed.
 - b. 2861-03-03-03 Wiring Harness, Injector, Replacement (Rear), Valve Cover Removed
19. Refer to IMPACT document ID: 2115-03-02-02 *Valve Cover, Replacement* for valve cover install procedure.
20. Using PTT Operation 1700-22-03-06 Program accessory kit: **85156014**
Note: Running this kit without removing the ePRV will result in adverse vehicle affects.