



# Service Bulletin

Bulletin No.: 23-NA-135

Date: August, 2023

## INFORMATION

**Subject: Information on Oil Level Control Changes and Compatibility on 2023-2024 9-Speed Transmissions**

Brand:	Model:	Model Year:		VIN:		Engine:	Transmission:
		from	to	from	to		
Buick	Enclave	2023	2024				M3W
	Encore GX						M3F
	Envision						M3H
Cadillac	XT4	2023	2024				M3H
	XT5						M3G, M3W
	XT6						M3G, M3W
Chevrolet	Blazer	2023	2024				M3T, M3V
	Trailblazer		2023				M3F
	Traverse		2023				M3V
GMC	Acadia	2023	2023				M3G, M3W
	Terrain		2024				M3U

<b>Involved Region or Country</b>	North America, Europe, Kazakhstan, Uzbekistan, Russia, Middle East, Israel, Palestine, Bolivia (West), Chile (West), Colombia (West), Japan, Cadillac Korea (South Korea), GM Korea Company, China - SGM, Taiwan, Other Africa
<b>Information</b>	<p>The purpose of this bulletin is to inform the Service Department Personnel about an update to the GM 9-speed transmission automatic transmission fluid Oil Level Control system (OLC). The purpose of the system is to store fluid in the side cover as the transmission warms up.</p> <p>The system used from the beginning of the 9-speed transmission thru 2023 consists of:</p> <ul style="list-style-type: none"> <li>• standpipe with a thermal door</li> <li>• on/off solenoid</li> <li>• valve</li> </ul> <p>The changes to the system starting with 2024 MY and some 2023 models with the RPO BCE are described below.</p>

**Important: Service agents must comply with all International, Federal, State, Provincial, and/or Local laws applicable to the activities it performs under this bulletin, including but not limited to handling, deploying, preparing, classifying, packaging, marking, labeling, and shipping dangerous goods. In the event of a conflict between the procedures set forth in this bulletin and the laws that apply to your dealership, you must follow those applicable laws.**

### Additional Information

**Note:** With OLC (w/OLC) means original design of OLC system. Without OLC (w/o OLC) means the new design of the OLC system.

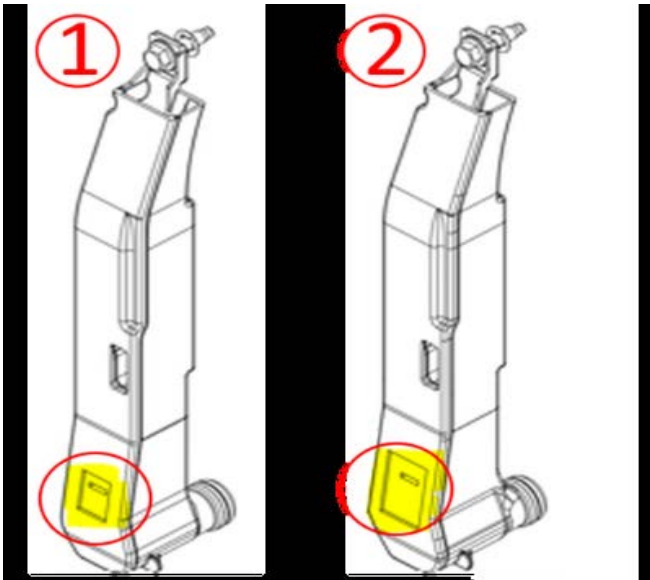

6396977

- 1) To only be used in model year 2022 and prior.
- 2) Can be used in any model year.

The previous a/trans fluid level control valve on the standpipe (item #21) had a small thermal door. The new style can be recognized by the larger thermal door on the standpipe. The larger thermal door is necessary for the removal of the OLC components.

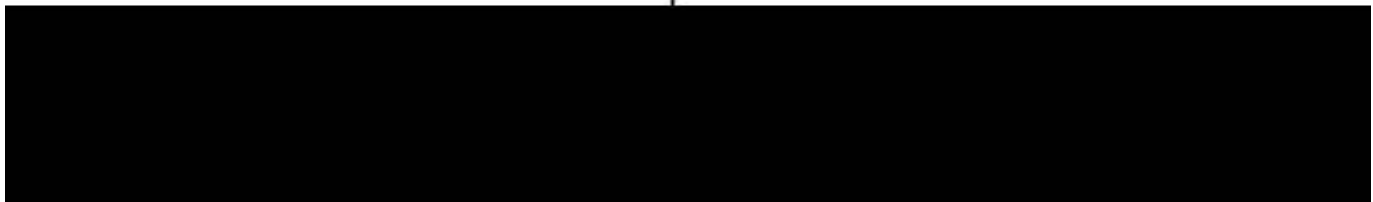

6396979

- 1) For use in model year 2023 and prior (w/OLC).
- 2) For use in model year 2024 and forward (w/o OLC).

The valve body will eliminate the a/trans fluid valve (item #437 and #436).

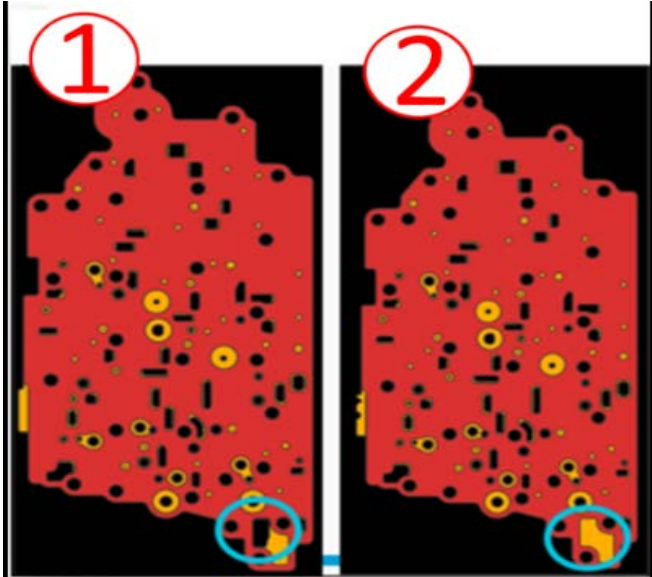

6397367

- 1) For use in model year 2023 and prior (w/OLC).
- 2) For use in model year 2024 and forward (w/o OLC).

The valve body to transmission case spacer plate is covering over the port (item #456).

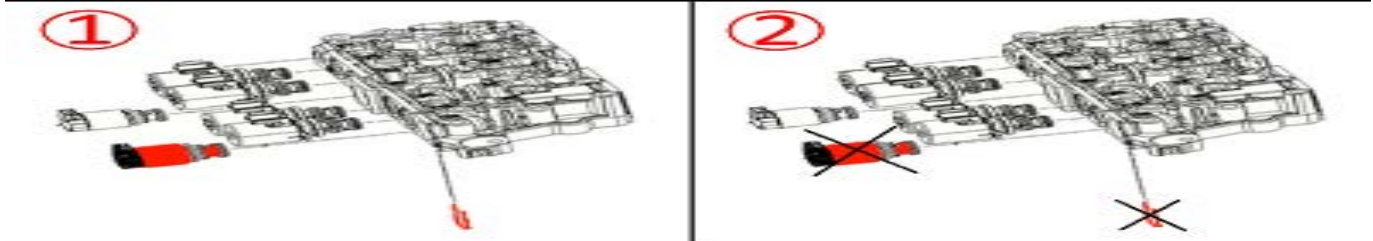

6397498

- 1) For use in model year 2023 and prior (w/OLC).
- 2) For use in model year 2024 and forward (w/o OLC).

The solenoid body will eliminate the a/trans fluid control solenoid (item #403).

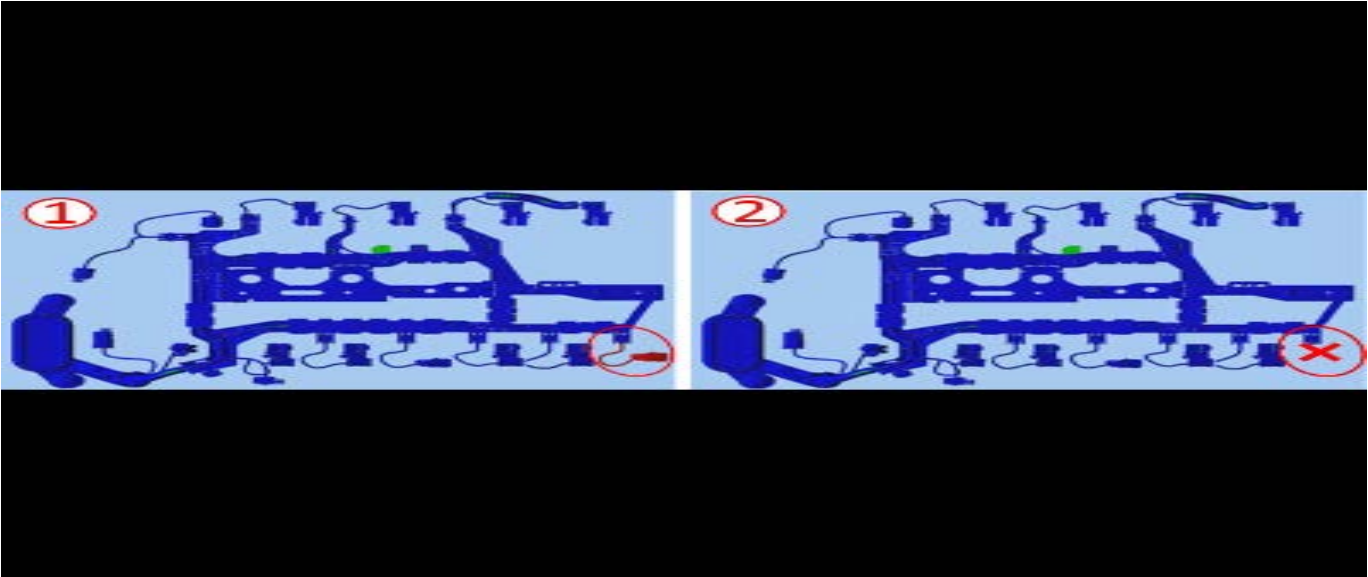

6397499

- 1) For use in model year 2023 and prior (w/OLC).
- 2) For use in model year 2024 and forward (w/o OLC).

**Note:** Both valve body covers are Interchangeable.

- 1) Old Design
- 2) New Design

The a/trans wiring harness will eliminate the wire for the a/trans fluid control solenoid (item #31).

The previous style valve body cover did not have a plug hole in it. The new style cover will have a plug. This new plug should **not** be removed as it is used by the assembly plant only.

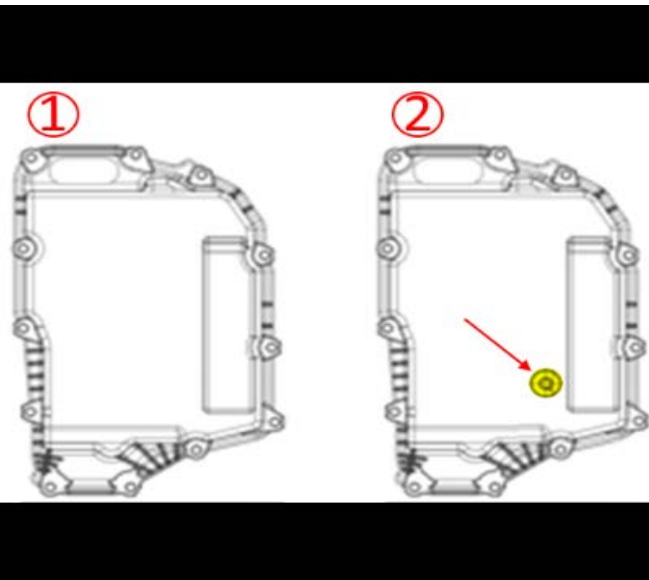

6397504

When servicing these transmission components, the technician **must** use the parts that are specified in this TSB for the model year being repaired. There is a possibility the components for a 2024 vehicle may be the old style. This is **not** a concern or a mis-build, this is to facilitate the manufacturing process. This is possible because the 2024 and 2023 RPO BCE transmission calibration ignores those component inputs.

Transmission quality concerns (up to and including transmission failure) can occur if transmissions are not serviced according to instructions.

Version	2
Modified	Released July 31, 2023 Revised August 16, 2023 - Added 2023 to 2024 to Model Year, Update the Information and Additional Information sections.

