



# Service Bulletin

Bulletin No.: 21-NA-067

Date: August, 2023

## TECHNICAL

**Subject: Foam Strip Between I/P Trim and Base of Windshield Detaching from Upper I/P Trim Panel**

Brand:	Model:	Model Year:		Date Breakpoint:		Engine:	Transmission:
		from	to	from	to		
Chevrolet	Silverado 1500 (New Model)	2019	2019	-	-	All	All
	Silverado 1500 Models (including All 2022 models)	2020	2024				
	Silverado 1500 LTD (RPO J21, VIN Digit 5 = W / Y)	2022	2022				
	Silverado 1500 New (RPO J22, VIN Digit 5 = A / D)						
	Silverado 2500HD/3500HD	2020	2024				
GMC	Sierra 1500 (New Model)	2019	2019	-	-	All	All
	Sierra 1500 Models (including All 2022 models)	2020	2024				
	Sierra 1500 Limited (RPO J21, VIN Digit 5 = 8 / 9)	2022	2022				
	Sierra 1500 New (RPO J22, VIN Digit 5 = H / U)						
	Sierra 2500HD/3500HD	2020	2024				

<b>Involved Region or Country</b>	Canada, Mexico, Europe, Kazakhstan, Uzbekistan, Russia, Middle East, Iraq, Israel, Palestine, Argentina (Mercosur), Brazil (Mercosur), Bolivia (West), Chile (West), Colombia (West), Ecuador (West), Paraguay (West), Peru (West), Uruguay (West), Venezuela (West), Other Central America, Japan, Cadillac Korea (South Korea), GM Korea Company, China - SGM, Taiwan, Thailand (ASEAN), Singapore, Philippines, Australia/New Zealand, Caribbean, Egypt, Other Africa, South Africa
<b>Additional Options (RPOs)</b>	Equipped with Trim Package GFF, GF2, GPZ, GF4, or GF5
<b>Condition</b>	Some customers may comment on seeing the foam strip between the I/P trim, and the base of the windshield, detaching from the upper I/P trim panel.
<b>Cause</b>	The cause of the condition may be that the grained surface of the upper I/P trim panel creates adhesion issues with the foam strip.
<b>Correction</b>	Following the steps in the Service Procedure below, surface treat the first 30 mm (1.20 in) of the upper I/P trim panel and replace the foam strip.

### Service Procedure

**Important:** Service agents must comply with all International, Federal, State, Provincial, and/or Local laws applicable to the activities it performs under this bulletin, including but not limited to handling, deploying, preparing, classifying,

packaging, marking, labeling, and shipping dangerous goods. In the event of a conflict between the procedures set forth in this bulletin and the laws that apply to your dealership, you must follow those applicable laws.

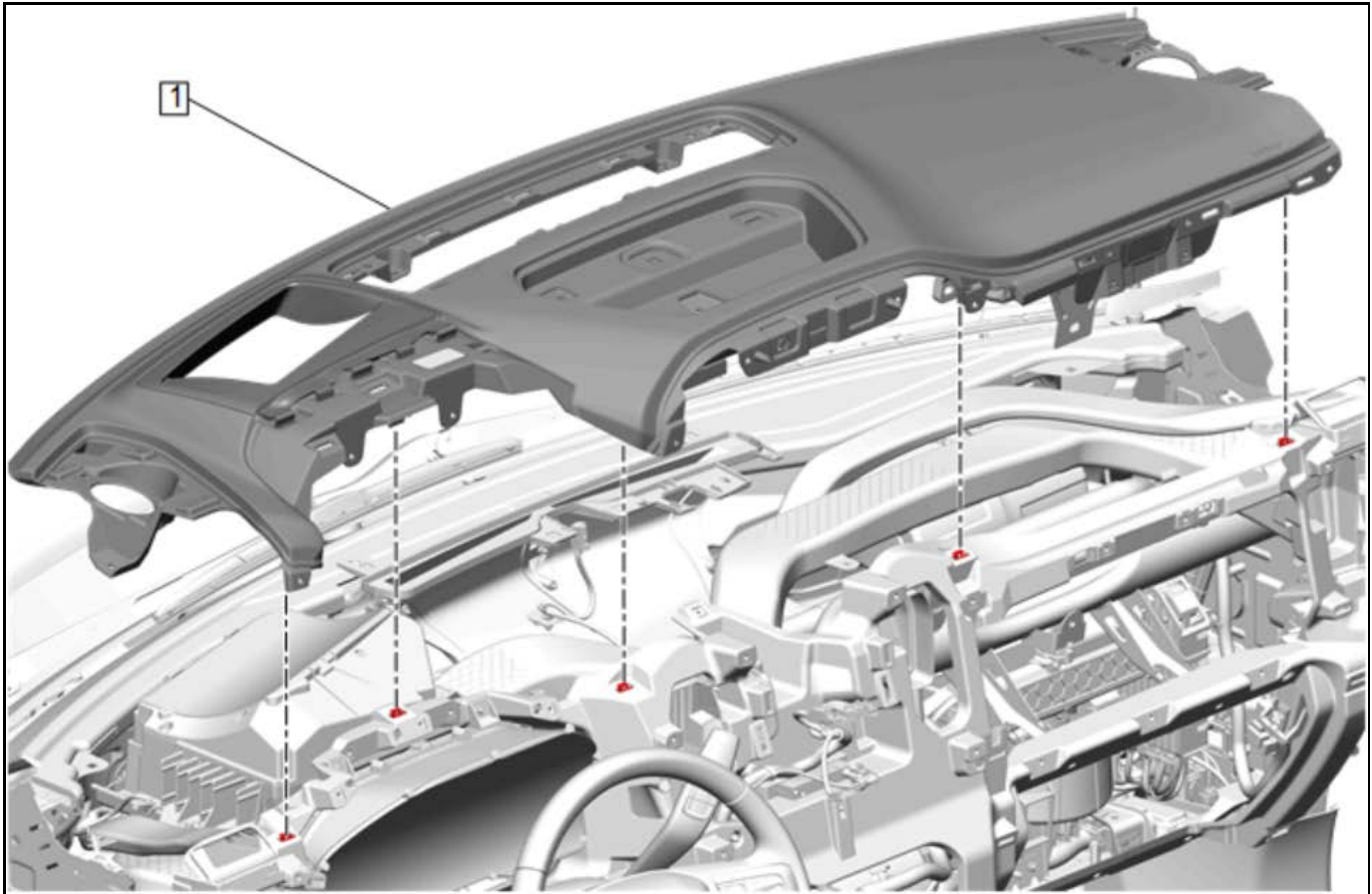

5028473

1. Remove the instrument panel (1). Refer to *Instrument Panel Removal and Installation*, in SI,

2. Peel off the existing foam strip (1).

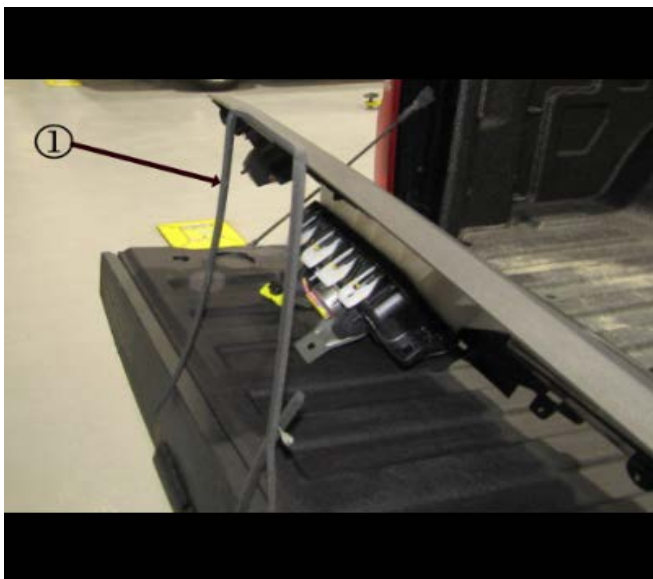

5776426



5776428

- Using a Sterile Alcohol Prep Pad, or equivalent, wipe off any residue and adhesive film from the IP panel.

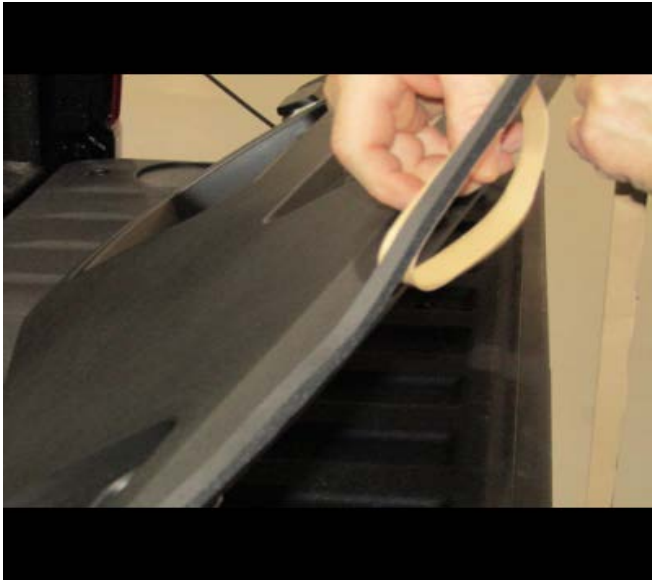

5776430

**Note:** For ease of installation, the foam strip is slightly longer than the IP panel, and the excess will need to be trimmed from the finishing end.

**Important:** The new service part has an extremely strong adhesive. Ensure it is correctly positioned when installing, because you will not be able to peel it off and reposition it.

- Once air dry, starting at either end, install the new replacement foam strip to the IP panel.



5776431

- Trim any excess length of the foam at the end of the IP panel.

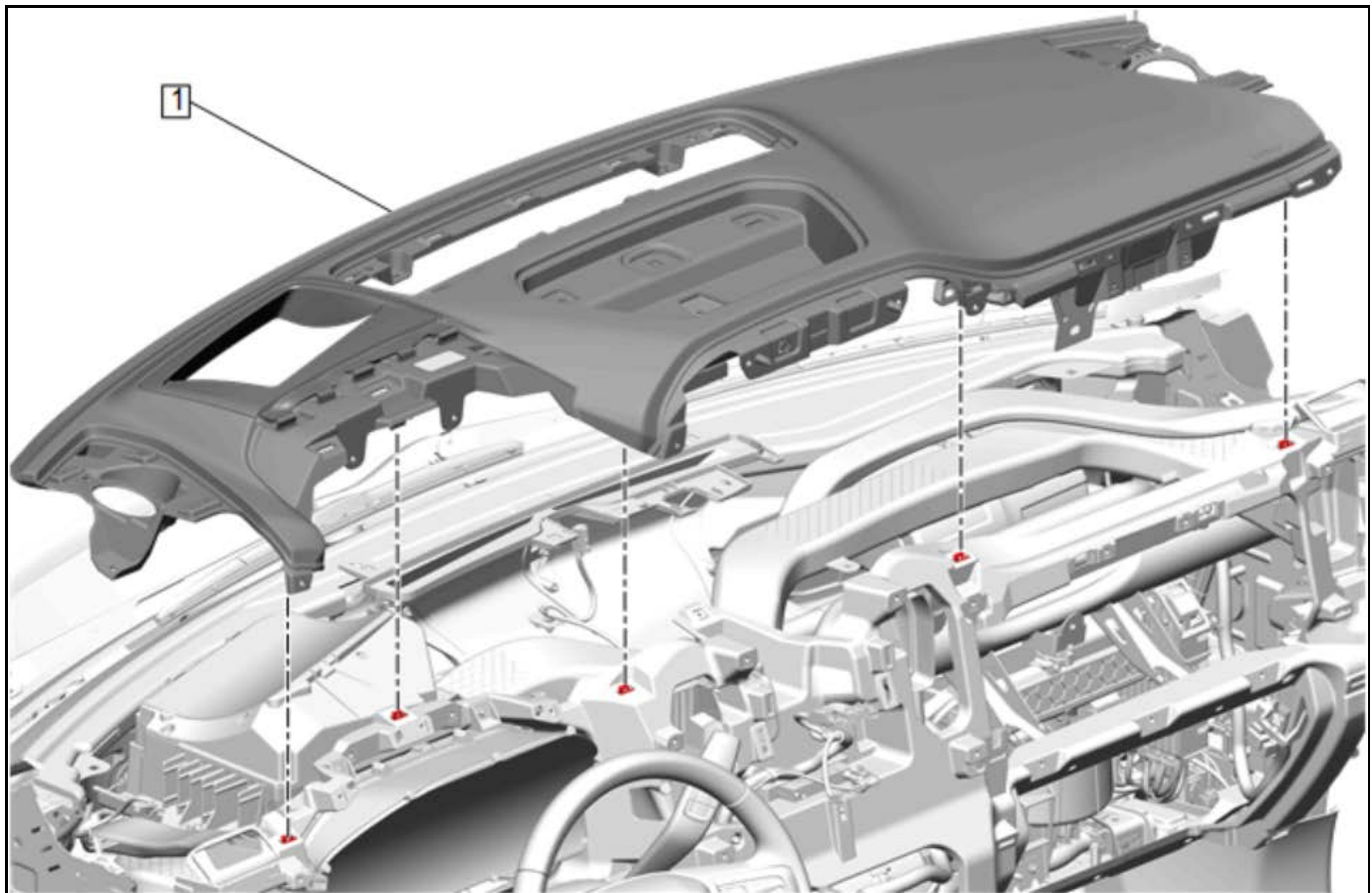

5028473

6. Reinstall the instrument panel (1). Refer to *Instrument Panel Removal and Installation*, in SI,

## Parts Information

Causal Part	Description	Part Number	Quantity
X	SEAL-I/P TR PAD	85521054	1

## Warranty Information

For vehicles repaired under the Bumper-to-Bumper coverage (Canada Base Warranty coverage), use the following labor operation. Reference the Applicable Warranties section of Investigate Vehicle History (IVH) for coverage information.

Labor Operation	Description	Labor Time
1086348*	Replace IP Foam Strip at Base of Windshield	2.5 hrs
*This is a unique Labor Operation for Bulletin use only.		

<b>Version</b>	4
<b>Modified</b>	Released February 07, 2023 Revised February 17, 2023 – Add 2021 Model Year. Revised May 12, 2023 — Added 2022–2023 Model Years, Updated RPO's and Cause. Revised August 18, 2023 – Added 2024 Model Year and GF4 RPO.

