



# Service Campaign 73-04

**MODELS**

**AFFECTED:** 2023 Vista, Sunstar & Adventurer

**DATE:** June 16, 2023

**SUBJECT:** Window Trim Rings & Taillight Sealant

**PLEASE FORWARD THIS INFORMATION TO YOUR RV SERVICE MANAGER.**

Winnebago Motorhomes is conducting a Field Service Campaign on certain 2023 Vista, Sunstar and Adventurer models. The window trim rings need to be inspected for proper installation, and the taillights for proper sealant.

**Affected Vehicles and Owner Notification**

Attached to this letter is a list of subject vehicles which were shipped to your dealership. Customers with affected vehicles are being sent a letter notifying them of the service campaign. Owners are directed to contact a Winnebago Motorhome dealer for the service campaign to be performed at no cost to them. A copy of the owner notice is provided for your information.

**Repair Procedure:**

Refer to instruction sheet.

**Reimbursement**

When the service has been completed, submit a warranty claim using the operation number and TIC code listed below.

DESCRIPTION	OPERATION NUMBER	TIME ALLOWANCE	TIC CODE
Window Trim Rings & Taillight Sealant	05730499	1.0	7304SB

If the vehicle is out of warranty, use service authorization 73G7304T when filing your claim.

**FINAL CLAIMS NEED TO BE SUBMITTED BY DECEMBER 16, 2023.**

Perform this procedure on all subject vehicles currently in your inventory. DO NOT DELIVER ANY SUBJECT UNITS TO A CUSTOMER UNTIL THIS CORRECTIVE ACTION HAS BEEN TAKEN.

**If You Need Assistance**

If dealer technical assistance is needed, please contact the Winnebago Motorhome Technical Service Department at (866) 653-4329 from 8:00 a.m. to 4:30 p.m. Central Time or by e-mail at: [techservice@wgo.net](mailto:techservice@wgo.net).

Thank you for your cooperation.

Dean Casad  
Director, Customer Support



## Window Trim Ring & Taillight Sealant

### Tools Required:

- Screw gun w/Phillips Tip
- Butyl Tape
- Manus Sealant

Read the entire instructions carefully before starting the procedure. If you have any questions, please contact Winnebago Industries' Technical Service Department by calling 1-866-653-4329 or by email: techservice@wgo.net. This document is confidential and is intended for dealer use only.

### Procedure:

1. Inspect all windows in coach (excluding sliding cab windows) to ensure the interior trim ring is placed in the proper orientation. The trim ring should 'step in' towards the installer. If found to be oriented wrong (Fig 1), remove the trim ring and reverse the orientation (Fig 3). Fig 2 shows the orientation from the supplier print.



**Fig 1 - INCORRECT** installation - trim ring steps out away from the installer.

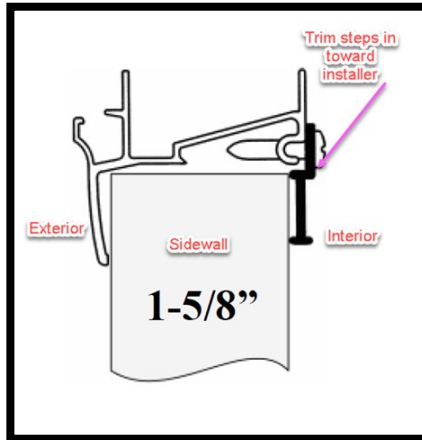

**Fig 2 - Trim Ring orientation** from supplier print.



**Fig 3 - CORRECT** installation - trim ring steps in towards the installer.

2. Remove any labels that are not concealed by window treatments.



**Fig 4**

3. Remove taillight pods and inspect to see if they are sealed. If properly sealed, skip to Step 6. If not sealed, follow sealing procedure below.
4. With taillight pods removed, place a backing material such as foam or butyl tape into the hole for the wires and ensure there are no voids. This material is intended to provide a backing for the sealant in the next step. (Fig 5)

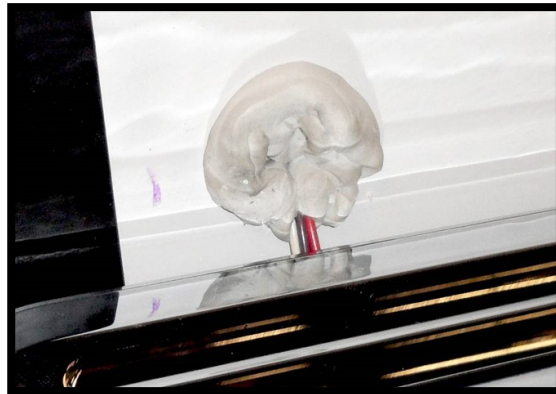

**Fig 5**

5. Cover the wire hole with sealant. The sealant should be tooled to completely surround each wire and cover the entire hole, including the edges. Ensure sealant completely encapsulates each wire and there are no voids. (Fig 6)

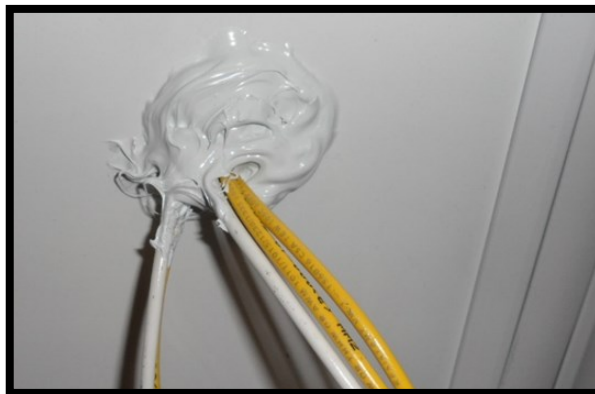

**Fig 6**

6. Place butyl tape over screw holes on backside of taillight pods that go into the backwall when attached. (Fig 7)



**Fig 7**

7. Reinstall taillight pods.



**FOR YOUR INFORMATION  
-COPY OF OWNER INFORMATION-**

RE: BODY SERIAL  
CHASSIS SERIAL

Dear Winnebago RV Owner:

When you purchased your new Winnebago RV, you also received our commitment to provide you with a quality product and our dedication to continuing customer satisfaction. In keeping with this commitment, we are notifying you of a service campaign that may affect your Winnebago RV.

Winnebago is conducting a Field Service Campaign on certain 2023 Vista, Sunstar and Adventurer models. The window trim rings need to be inspected for proper installation, and the taillights for proper sealant.

Our records indicate that you have purchased a vehicle with the serial number which appears above.

**What We Will Do**

Your Winnebago dealer will inspect the window trim ring installation as well as the taillight sealant and correct if needed.

**What You Should Do**

Contact your Winnebago dealer to arrange for a service appointment. Please allow sufficient time for your dealer to process your vehicle on the date of the appointment. The actual repair will take approximately 1 hour however your dealer may require additional time to process your coach.

**Important**

This campaign and offer to provide service is at NO COST TO YOU and is valid until December 16, 2023, at which time the campaign will be closed.

**If You Need Assistance**

If you have questions or need assistance, please contact Winnebago Motorhome Customer Care at (800) 537-1885 Monday through Friday from 8:00 a.m. to 4:30 p.m. Central Time or by email: [customer care@wgo.net](mailto:customer care@wgo.net).

We are sorry to cause you this inconvenience. We have taken this action in the interest of your continued satisfaction with our products. This letter does not constitute an acknowledgement of legal liability.

Thank you for choosing a Winnebago RV.

Winnebago  
Forest City, IA 50436