

This document is uncontrolled when printed. Before use, check the Knowledge Base within the McLaren Retailer Portal to verify that this is the current version.

Document Information

Location: Powertrain

Topic: McLaren Artura Engine Oil Leak Diagnosis Guide - Front of Engine

Condition: N/A

Diagnostic Trouble Codes: N/A

Measure

This guide will help to correctly diagnose oil leaks identified on the engine of the McLaren Artura

If an Artura is found to have oil traces on the underside of the car at the front of the engine bay, specifically the front of the engine around the torsional vibration damper (TVD) area, please follow the steps below:

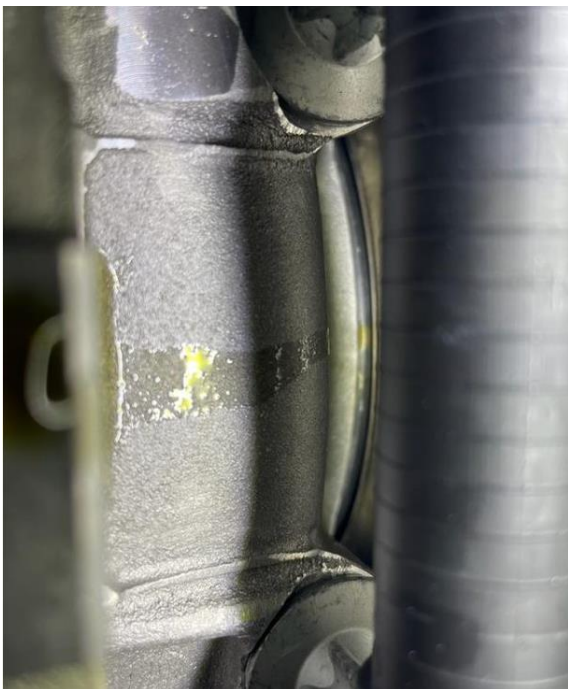

1. Raise vehicle on ramp as per SIS instructions
2. Remove engine underfloor
3. Capture images prior to any cleaning, clearly showing the leaking area. Label images: "Pre-Cleaning"
4. Take picture of engine number and label image "Engine Number"
5. Clean area thoroughly using degreaser/solvent
6. Add engine oil dye to the engine - Please refer to latest update of [KA-01458](#) for correct dye and torch to use

Care Point: Do Not use leak detector spray / chalk spray

7. Start engine and run at increased idle speed (3,000 rpm) using engine oil check procedure until procedure is complete (this will ensure that the engine oil temperature reaches 90°C)

8. Turn off engine and allow vehicle to stand for 20 minutes on the ramp in preparation for inspection

9. Inspect engine. Capture images and label images "Cycle 1", clean area again thoroughly, capture images and label images "Post Cycle 1"

Care Point: If there is a clear and active leak after step 9, please stop the warm up cycles and submit a TR with supporting images/video

10. Complete warm up/cool down cycle and inspection a further 4 times capturing images. Name image folders respectively:

- "Cycle 2" & "Post Cycle 2 (after cleaning)"
- "Cycle 3" & "Post Cycle 3 (after cleaning)"
- "Cycle 4" & "Post Cycle 4 (after cleaning)"
- "Cycle 5" & "Post Cycle 5 (after cleaning)"

Care Point: In case of uncertainty on final assessment, please update TR with supporting images correctly labelled

Care Point: If no further oil leak is observed, then the initial oil residue is potentially due to excessive oil used in the build process

11. If there is obvious evidence of an oil leak from the front of the engine after the 5 cycles please submit a Technical Request with clear pictures showing the leak. If no leak is present, carry out a road test (including EV mode), refer to [KA-01633](#) and recheck for leaks. Capture images and label "Post Road Test" (before cleaning)

Care Point: If no further oil leak is observed, then the initial oil residue found previously is due to excessive oil used in the build process - No further action required

12. Identify the location of the oil leak using a UV light

- TVD bolts
- Front of engine behind the TVD (front crankshaft seal)

13. Follow the SIS instructions to drain the oil from the engine

Care Point: The engine oil MUST be FULLY drained before continuing

14. Remove the TVD recording the crack off torque & back-to-mark (BTM) torque

If the digital torque wrench used does not have crack-off torque capability then only record BTM torque by following this procedure:

- mark the bolt
- untighten/crack-off by ~30°
- tighten back to mark (smooth and slow movement) and record the torque

Remove and inspect each TVD bolt for signs of oil one at a time, starting from 12 O'clock position labeling the bolts in the order of removal (clockwise) and lay down each bolt on a piece of white A4 paper with the bolt head

down (threads pointing up). Capture images of the oily bolts and their respective bolt holes on the crankshaft flange – label as “Oil Presence on TVD Bolt and Crankshaft Flange threaded hole”

Care Point: Carefully remove the TVD to preserve the oil on any components, this will help with identification. Do not clean any parts at this stage and ensure the area is not contaminated with oil from an external source

Capture images immediately of the TVD and label images as “TVD Surface Bulkhead Side” & “TVD Surface Engine Side Inspection” and inspect

If oil is centralized around the TVD on the surface (Engine Side – contact with crank shaft flange) or under the heads of the TVD bolts, this might indicate that the TVD bolts are potentially the cause of the leak

Care Point: Do not clean, capture images of leaking areas and label as “Front of engine TVD Removed”

15. Identify leaking area of the front of the engine

1.
 1. TVD threaded bolt holes (crankshaft flange) and TVD Bolts
 2. Front crank seal OD
 3. Front crank seal ID

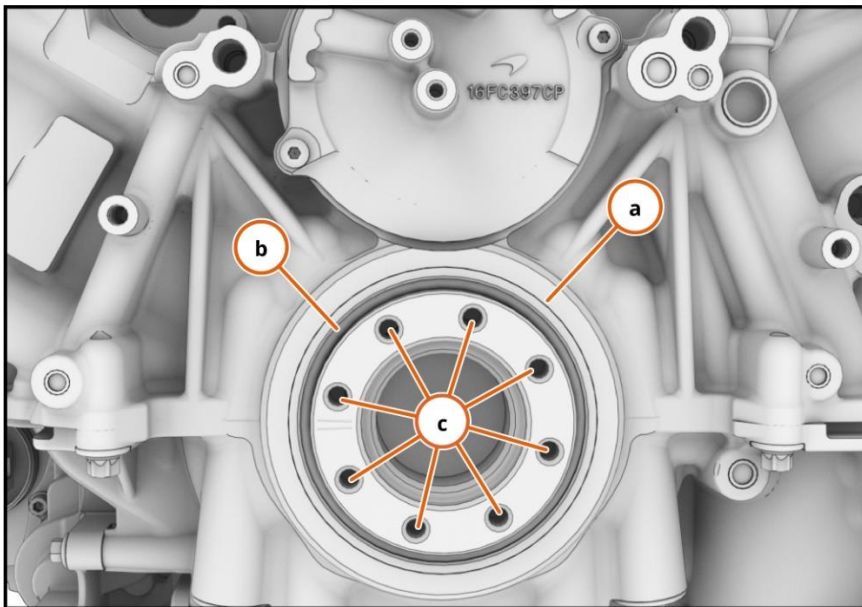

Repair: If the engine is only leaking from the TVD bolts skip steps 17 to 19 (front crank seal removal)

16. Capture Images and label “Clean Crankshaft-TVD-Block Interface pre front crank seal removal”

Care Point: to avoid engine contamination, prior to attempting front crank seal removal clean the first 2-3 bolt hole threads (crankshaft flange) from residual threadlocker (from the original bolt fitment) and outer surface of crankshaft flange (threadlocker and oil) without pushing any debris into the engine (through holes), clean with standard automotive degreaser/solvent ensuring a thorough clean of the leak area. Do not leave the area like this:



17. Follow the SIS instructions to remove the Front Crank Seal

Care Point: Avoid damage to seal lip if this is the area that is clearly identified to have leaked by removing the seal winding two small self-tapping screws into the aluminum outer rim and levering the seal out. Be careful not to damage the cover plate



Care Point: Do not damage the cylinder block front crank seal bore and the crankshaft

18. Follow the SIS instructions to prepare the parts, surfaces, and fitment of the Front Crank Seal

Capture images of clean front crank seal interface and label as "Clean Front Crank Seal Interface pre assembly"

Care Point: Handle the New Front Crank Seal with extra care. DO NOT TOUCH the LIP of the Crank Seal (any contact, local pressure applied to the lip seal will cause it to distort and cause an oil leakage when the engine is running)

All other alignment, cleaning, and RTV processes in SIS instructions are correct and should be adhered to when fitting the front crank seal

Care Point: It is essential that the new mandrel (service tool PN 16FA064ZT) is used during this process to slide the seal onto the crank shaft when fitting the new front seal and the cup to press in the seal into the block

19. With the brand-new front crank seal halfway down the mandrel, apply constant thickness of RTV to the outer surface/OD of the metallic ring of the seal (complete, 360° coverage) as follows (DO NOT contaminate the lip seal or the mandrel with RTV):



Care Point: Clean carefully with a dry lint free cloth the RTV squeeze-out post Front Crank Seal fitment
Attention! If any trace of RTV accidentally contaminates the lip seal, replace the Crank Seal and repeat Steps 17 & 18

Capture images post seal fitment and cleaning and label as "Clean Front Crank Seal Post Assembly"

20. Follow the SIS instructions to prepare the parts, surfaces, and fitment of the TVD

When fitting the TVD, clean the first 2-3 bolt hole threads (crankshaft flange) from residual threadlocker (from the original bolt fitment) and outer surface of crankshaft flange without pushing any debris into the engine (through holes)

Clean with standard automotive degreaser/solvent ensuring a thorough clean of the leak area.

Capture images pre fitment of the TVD, label as "Clean Front Crank Seal Interface Pre TVD Fitment"

TVD Bolts:

If new bolts are available, apply Loctite 243 radially to the first 4-6 -threads as follows:

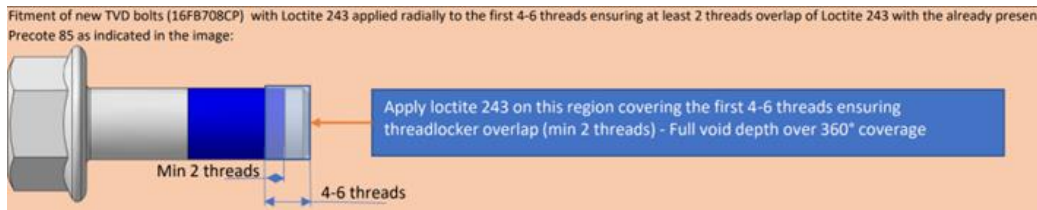

If new TVD Bolts are not available, the original bolts can be reused by thoroughly cleaning the threads of debris and original threadlocker and applying Loctite 243 radially to the first 12-19 thread ensuring full void depth over 360° coverage as follows:

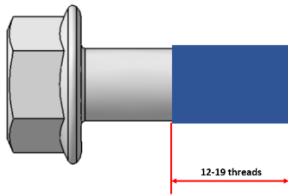

21. Follow the SIS procedure to install the TVD using the bolts applied with Loctite 243

Care Point: Once the TVD is installed, allow the Loctite 243 activated by the mechanical interaction of the threads to cure for a minimum of 6 hours before filling the engine with oil

This step will prevent the oil from reaching the threadlocker and interfering with the curing process and potentially impacting the sealing performance of the threadlocker

Once the minimum 6 hours (required for the threadlocker curing process) have passed, follow the SIS instructions to fill the system with oil and rebuild the Powertrain up to the point where you can start the engine

Repair Validation:

With the floor panel removed, follow Steps 1 to 9 to validate that no leak is present anymore

Once this test has been successfully completed (no oil leaks), rebuild the vehicle as per SIS instructions

After performing the engine health checks and a road test ([KA-01633](#)), return the vehicle on the ramp and inspect for any leakages

Remove the engine underfloor to check and confirm that the repaired area has remained dry

Parts Information

N/A

Attachments

N/A

KA Update Information

This document is uncontrolled when printed. Before use, check the Knowledge Base within the McLaren Retailer Portal to verify that this is the current version.