



# Technical Service Bulletin

SUBJECT:			No: <b>TSB-23-14-001</b>
<b>BOLT TORQUE FOR RADIATOR COOLING FAN SHROUD – SERVICE MANUAL REVISION</b>			DATE: <b>August 2023</b>
			MODEL: <b>Eclipse Cross</b>
<b>CIRCULATE TO:</b>	<input type="checkbox"/> GENERAL MANAGER	<input checked="" type="checkbox"/> PARTS MANAGER	<input checked="" type="checkbox"/> TECHNICIAN
<input checked="" type="checkbox"/> SERVICE ADVISOR	<input checked="" type="checkbox"/> SERVICE MANAGER	<input checked="" type="checkbox"/> WARRANTY PROCESSOR	<input type="checkbox"/> SALES MANAGER

## PURPOSE

This TSB provides updated bolt torque information for the Radiator Cooling Fan Shroud in the applicable Service Manual sections:

- Engine Cooling

## AFFECTED VEHICLES

2018-2023 Eclipse Cross

## AFFECTED SERVICE MANUAL

- 2018-2023 Eclipse Cross Service Manual

## PROCEDURE

Please use the following chart as a guide to replace the indicated pages in the affected Service Manuals, Group 14, Engine Cooling, Radiator, Removal and Installation.

Applicable Manual	Pub. No.	Applicable Title	Contents
2018 ECLIPSE CROSS Service Manual	MSCD-020B-2018	ENGINE COOLING ↳ RADIATOR ↳ REMOVAL AND INSTALLATION	Attached sheet 1
2019 ECLIPSE CROSS Service Manual	MSCD-020B-2019		
2020 ECLIPSE CROSS Service Manual	MSCD-020B-2020		
2021 ECLIPSE CROSS Service Manual	MSCD-020B-2021	ENGINE COOLING ↳ RADIATOR ↳ REMOVAL AND INSTALLATION	Attached sheet 2
2022 ECLIPSE CROSS Service Manual	MSCD-020B-2022		
2023 ECLIPSE CROSS Service Manual	MSCD-020B-2023		



Copyright 2023, Mitsubishi Motors North America, Inc.

The information contained in this bulletin is subject to change. For the latest version of this document, go to the Mitsubishi Dealer Link, MEDIC, or the Mitsubishi Service Information website ([www.mitsubishitechinfo.com](http://www.mitsubishitechinfo.com)).

# ENGINE COOLING RADIATOR

## RADIATOR

### REMOVAL AND INSTALLATION

M1141001504987

#### Pre-removal and Post-installation Operation

- Front under cover panel and front extension under cover panel Removal and Installation (Refer to GROUP 51 - Under Cover ).
- Engine coolant Draining and Refilling.
- Intake duct and air cleaner assembly Removal and Installation (Refer to GROUP 15 - Air Cleaner ).
- Headlight support upper panel cover Removal and Installation (Refer to GROUP 51, Radiator Grille )

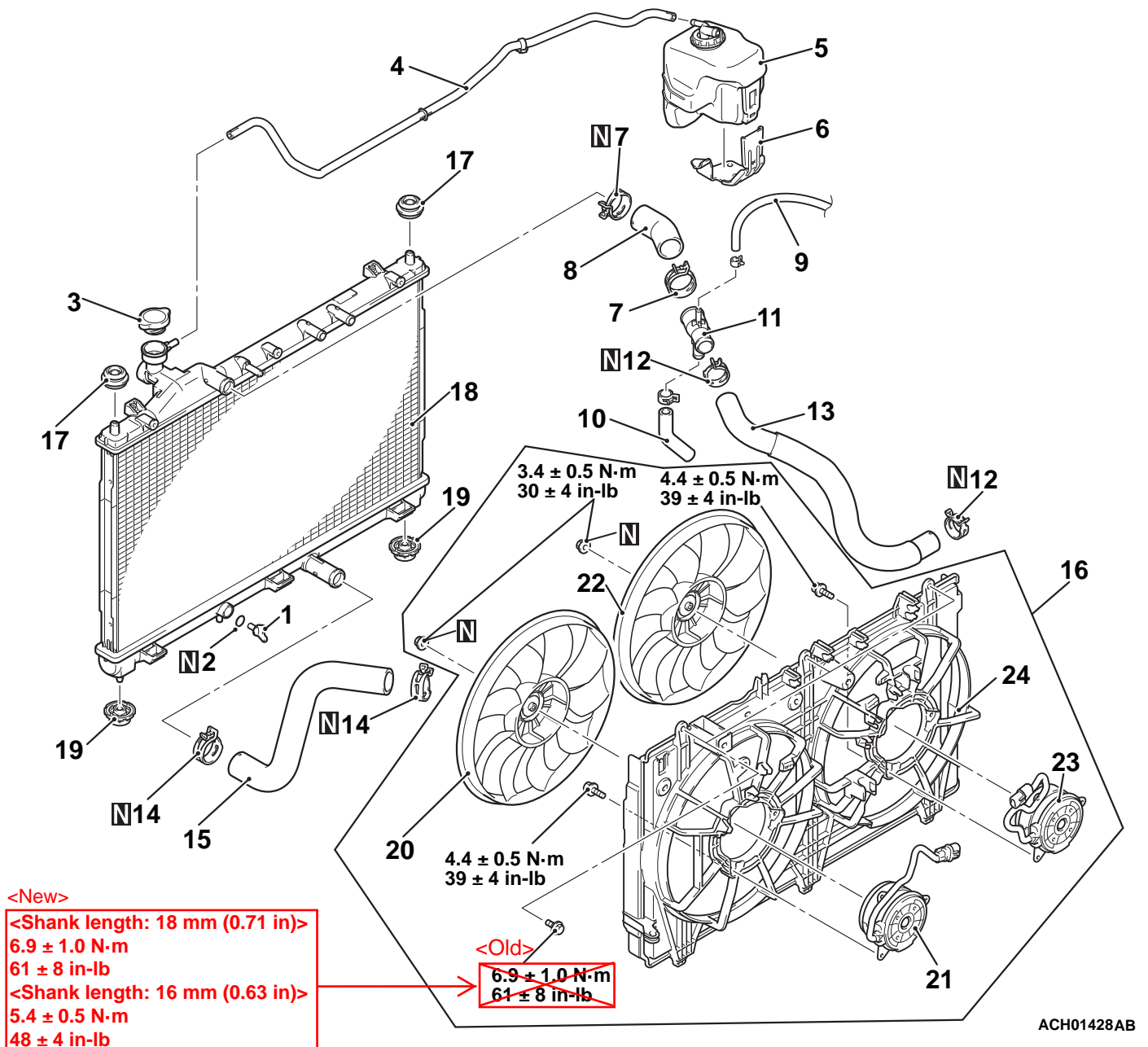

&lt;New&gt;

&lt;Shank length: 18 mm (0.71 in)&gt;

6.9 ± 1.0 N·m

61 ± 8 in·lb

&lt;Shank length: 16 mm (0.63 in)&gt;

5.4 ± 0.5 N·m

48 ± 4 in·lb

&lt;Old&gt;

6.9 ± 1.0 N·m

61 ± 8 in·lb

#### Removal steps

1. Radiator drain plug
2. O-ring

#### Removal steps

3. Radiator cap
4. Radiator condenser tank hose

## ENGINE COOLING RADIATOR

<From 22 Model year>

### Pre-removal and Post-installation Operation

- Engine Room Under Cover Front A, B Removal and Installation (Refer to GROUP 51 - Under Cover ).
- Engine Coolant Draining and Refilling.
- Air Cleaner Intake Duct and Air Cleaner Assembly Removal and Installation (Refer to GROUP 15 - Air Cleaner ).
- Headlight Support Upper Panel Cover Removal and Installation (Refer to GROUP 51, Radiator Grille )

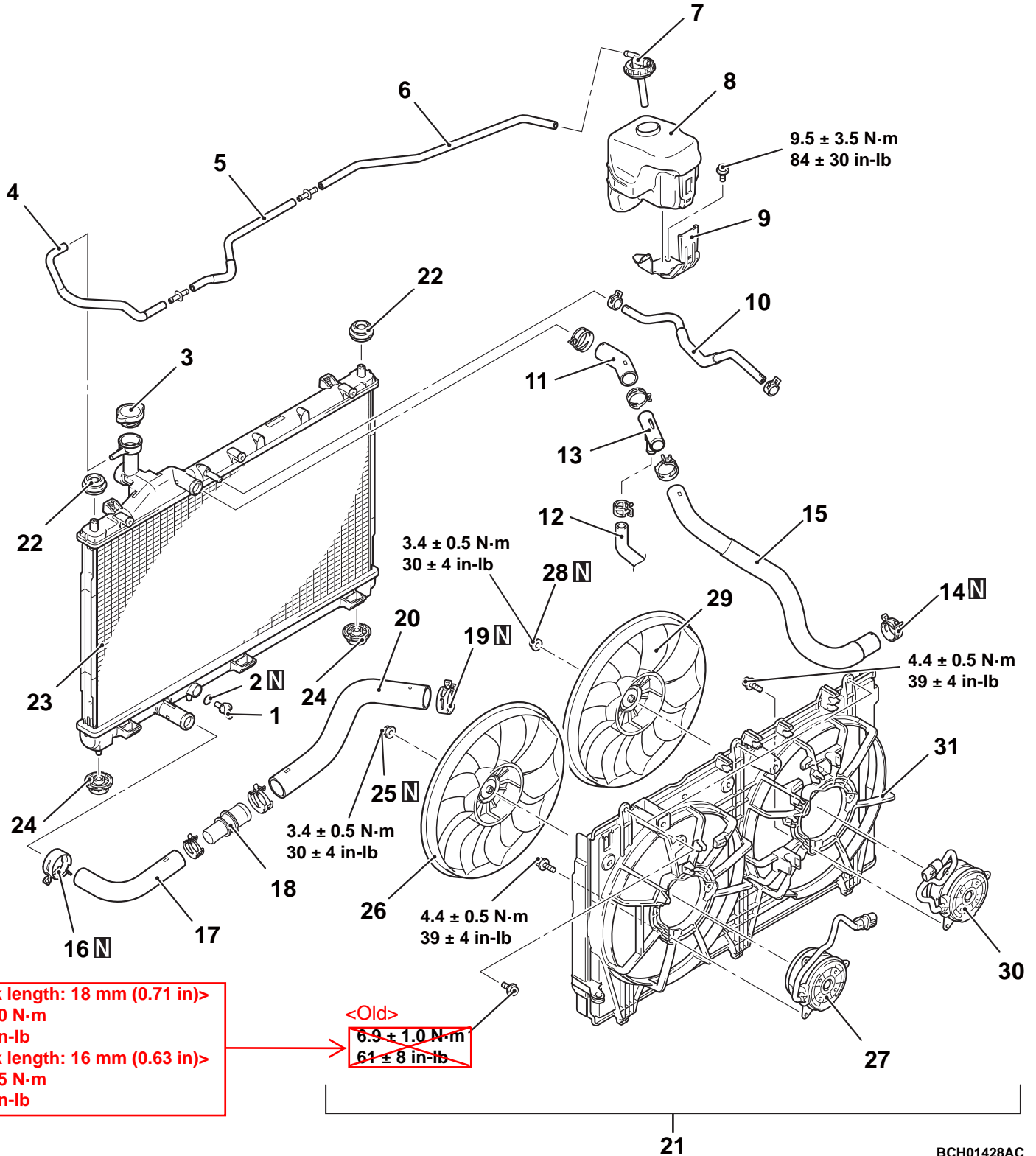

<New>

<Shank length: 18 mm (0.71 in)>

6.9 ± 1.0 N·m

61 ± 8 in-lb

<Shank length: 16 mm (0.63 in)>

5.4 ± 0.5 N·m

48 ± 4 in-lb

<Old>

~~6.9 ± 1.0 N·m~~

~~61 ± 8 in-lb~~

BCH01428AC