

Service Alert

Mazda North American Operations
Irvine, CA 92618-2922



Subject: Qi WIRELESS CHARGER SYMPTOM TROUBLESHOOTING	Service Alert No.: SA-021/23
	Last Issued : 08/28/2023

BULLETIN NOTES

This SA supersedes the previously issued SA(s) listed below. The changes are noted in Red.

Previous SAs:	Date(s) Issued:
SA-021/23	04/14/23
SA-028/22	05/02/22

APPLICABLE MODEL(S)/VINS

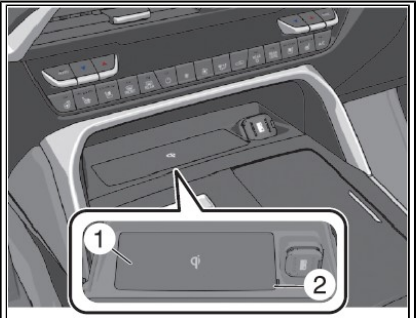
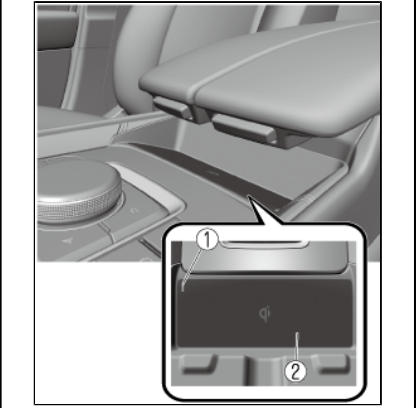
<p>2024 CX-90 equipped with factory installed Qi Wireless Charger</p>	 <p>1. Charging area 2. LED indicator</p>
<p>2023-2024 CX-50 equipped with factory installed Qi Wireless Charger 2023-2024 CX-50 equipped with Mazda Genuine Accessory Qi Wireless Charger</p>	 <p>1. LED indicator 2. Charging area</p>

CONSUMER NOTICE: The information and instructions in this bulletin are intended for use by skilled technicians. Mazda technicians utilize the proper tools/ equipment and take training to correctly and safely maintain Mazda vehicles. These instructions should not be performed by "do-it-yourselfers." Customers should not assume this bulletin applies to their vehicle or that their vehicle will develop the described concern. To determine if the information applies, customers should contact their nearest authorized Mazda dealership. Mazda North American Operations reserves the right to alter the specifications and contents of this bulletin without obligation or advance notice. All rights reserved. No part of this bulletin may be reproduced in any form or by any means, electronic or mechanical--including photocopying and recording and the use of any kind of information storage and retrieval system ---without permission in writing.

2022-2024 CX-5 equipped with factory installed Qi Wireless Charger
 2021-2023 CX-9 equipped with factory installed Qi Wireless Charger

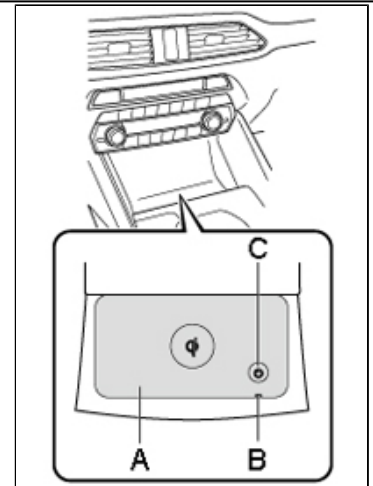

- A - Charging Area
- B - Indicator
- C - Power Button

2019-2024 Mazda3 equipped with Mazda Genuine Accessory Qi Wireless Charger
 2020-2024 CX-30 equipped with Mazda Genuine Accessory Qi Wireless Charger



- A - Charging Area
- B - Indicator

CONSUMER NOTICE: The information and instructions in this bulletin are intended for use by skilled technicians. Mazda technicians utilize the proper tools/ equipment and take training to correctly and safely maintain Mazda vehicles. These instructions should not be performed by "do-it-yourselfers." Customers should not assume this bulletin applies to their vehicle or that their vehicle will develop the described concern. To determine if the information applies, customers should contact their nearest authorized Mazda dealership. Mazda North American Operations reserves the right to alter the specifications and contents of this bulletin without obligation or advance notice. All rights reserved. No part of this bulletin may be reproduced in any form or by any means, electronic or mechanical--including photocopying and recording and the use of any kind of information storage and retrieval system ---without permission in writing.



DESCRIPTION

Index

[Symptom Troubleshooting](#)

[LED Indicator / Infotainment Display Icon](#)









[Supplemental Information](#)

	CX-50 Factory Installed and Mazda Genuine Accessory CX-5, CX-9 and CX-90 Factory Installed	Mazda3 and CX-30 Mazda Genuine Accessory Qi Wireless Charger
Symptom	Possible Cause	
Phone will not charge	<ul style="list-style-type: none"> Device is not compatible with Qi wireless charging standards (see trademark below)  <ul style="list-style-type: none"> Phone case is not compatible with Qi wireless charging standards <ul style="list-style-type: none"> Most phone cases will list compatibility on the packaging None approved phone cases with magnets or metal plates The engine is not running Doors and/or liftgate is open The mobile device is fully charged. Foreign matter between the device and the charging area The temperature of the mobile device is high The mobile device is placed with the charging side facing upward The mobile device is placed in a position extremely deviating from the center of the charging area The Near Field Communication (NFC) function setting of the mobile device is on (depends on the model of the mobile device) 	<ul style="list-style-type: none"> Device is not compatible with Qi wireless charging standards (see trademark below)  <ul style="list-style-type: none"> Phone case is not compatible with Qi wireless charging standards <ul style="list-style-type: none"> Most phone cases will list compatibility on the packaging None approved phone cases with magnets or metal plates Ignition Off The mobile device is placed in a position extremely deviating from the center of the charging area The temperature of the mobile device is high LED indicator error (see table below)

CONSUMER NOTICE: The information and instructions in this bulletin are intended for use by skilled technicians. Mazda technicians utilize the proper tools/ equipment and take training to correctly and safely maintain Mazda vehicles. These instructions should not be performed by "do-it-yourselfers." Customers should not assume this bulletin applies to their vehicle or that their vehicle will develop the described concern. To determine if the information applies, customers should contact their nearest authorized Mazda dealership. Mazda North American Operations reserves the right to alter the specifications and contents of this bulletin without obligation or advance notice. All rights reserved. No part of this bulletin may be reproduced in any form or by any means, electronic or mechanical--including photocopying and recording and the use of any kind of information storage and retrieval system ---without permission in writing.

	<ul style="list-style-type: none"> • Your vehicle is in an area where strong radio waves or electrical noise occur such as near a television tower, power plant, or airport. • Power Turned OFF <ul style="list-style-type: none"> ◦ Function can be switched on/off by pressing the power button on the Wireless Charger (Qi) for approx. 3 seconds • LED indicator error (see table below) • DTC is stored • Noise interference reduction function ON <ul style="list-style-type: none"> • Function can be switched on/off by pressing the power button on the Wireless Charger (Qi) for approx. 1 sec 	
Resources	<p>Go to MGSS:</p> <ul style="list-style-type: none"> • CX-50 WIRELESS CHARGER (Qi) INSPECTION • CX-9 WIRELESS CHARGER (Qi) INSPECTION • CX-5 WIRELESS CHARGER (Qi) INSPECTION 	

CONSUMER NOTICE: The information and instructions in this bulletin are intended for use by skilled technicians. Mazda technicians utilize the proper tools/ equipment and take training to correctly and safely maintain Mazda vehicles. These instructions should not be performed by "do-it-yourselfers." Customers should not assume this bulletin applies to their vehicle or that their vehicle will develop the described concern. To determine if the information applies, customers should contact their nearest authorized Mazda dealership. Mazda North American Operations reserves the right to alter the specifications and contents of this bulletin without obligation or advance notice. All rights reserved. No part of this bulletin may be reproduced in any form or by any means, electronic or mechanical---including photocopying and recording and the use of any kind of information storage and retrieval system ---without permission in writing.

CX-50, CX-90 Factory Installed and Mazda Genuine Accessory		CX-5 and CX-9 Factory Installed	Mazda3 and CX-30 Mazda Genuine Accessory	Customer Device	
LED Indicator	Infotainment Display Icon	LED Indicator	LED Indicator	Device Display	Infotainment Display Icon
No light - System Off	---	<ul style="list-style-type: none"> No light - System Off White - Stand-by (charging is possible) Amber - Normal charging Green - Fast charging Flashing White - Normal charging (charging efficiency is low) Flashing Green - Fast charging (charging efficiency is low) Flashing White - Stand-by (charging is not possible) Flashing red (charging pad high temperature is detected) Solid red (charger malfunction) 	<ul style="list-style-type: none"> No light - System Off White - Stand-by (charging is possible) Green - Charging Flashing White - Charge Complete *2 Orange (foreign matter detected or device high temp) Red (charger malfunction) 	<ul style="list-style-type: none"> Customer device high temperature <p>Example: iPhone</p> 	
White - Charging is possible					
Amber - Normal charging					
Green - Fast charging *1					
Flashing White - Charging conditions are not met *3					
Flashing red - Charging is not possible because charging pad high temperature is detected (Charging will resume when charging pad cools)	 Vehicle side				
Flashing red - Charging is not possible because: <ul style="list-style-type: none"> Customer device high temperature Foreign matter is detected Phone case is not compatible with Qi wireless charger 	 Customer device issue				

CONSUMER NOTICE: The information and instructions in this bulletin are intended for use by skilled technicians. Mazda technicians utilize the proper tools/ equipment and take training to correctly and safely maintain Mazda vehicles. These instructions should not be performed by "do-it-yourselfers." Customers should not assume this bulletin applies to their vehicle or that their vehicle will develop the described concern. To determine if the information applies, customers should contact their nearest authorized Mazda dealership. Mazda North American Operations reserves the right to alter the specifications and contents of this bulletin without obligation or advance notice. All rights reserved. No part of this bulletin may be reproduced in any form or by any means, electronic or mechanical--including photocopying and recording and the use of any kind of information storage and retrieval system ---without permission in writing.

