



SIB 52 09 20

2023-07-19

HEAD RESTRAINT AND/OR BACKREST OF 3RD ROW SEATS CANNOT BE FOLDED DOWN

This Service Information Bulletin (Revision 3) replaces SI B52 09 20 **dated June 2021**.

What's New:

- Cause, Procedure, Parts Information, Claim Information sections updated

<input type="checkbox"/>	THIS REPAIR IS MOBILE FRIENDLY
--------------------------	--------------------------------

MODEL

E-Series	Model Description
G07	X7 Sports Activity Vehicle

SITUATION

Various concerns about the third row of seats:

1. Head restraint (aka headrest), on one or both sides, cannot be folded down.
2. Third-row seating, on one or both sides, cannot be folded down.

CAUSE

1. Head restraint (aka headrest), on one or both sides, cannot be folded down:
 - Head restraint mechanism is faulty.
 - Bowden cable is not routed correctly, or not mounted.
 - Bowden cable mechanism (when cable is under tension it is too short)
 - Electric motor not fully pulling on common housing that moves the 3 Bowden cables.
 - Seat initialization required.
2. Third-row seating, on one or both sides, cannot be folded down:
 - Drivetrain for backrest release (actuator) is faulty or internally damaged.
 - Drivetrain for backrest tilt adjustment is faulty.
 - Bowden cable not correctly mounted.
 - Seat initialization required.

CORRECTION

Depending on the problem found, one or more of the following corrections will be required:

1. Perform seat initialization
2. Replace the head restraint mechanism
3. Replace the Bowden cable
4. Re-route the Bowden cable
5. Replace the drivetrain for backrest release (actuator)
6. Replace the drivetrain for backrest tilt adjustment

PROCEDURE

For an overview of seat operation, please refer to [SI B52 23 19](#).

Program the vehicle with ISTA to the most recent I-level.

Program the vehicle with ISTA to the most recent I-level.

NOTE: Software improvements were released August 2019 which changed certain seat operations on early production vehicles. For a detailed list of the changes see SI [B52 21 19](#).

All G05 / G07 produced up to August 1 2019 can be updated to 7/2019 SW as per Service Action SI [B65 19 19](#)

After programming perform seat initialization.

The seat initialization procedure can be found in ISTA by choosing

- SERVICE FUNCTIONS
- BODY
- SEATS
- SEAT ADJUSTMENT STANDARDIZATION

Then select the correct ABL test plan for the relevant seat(s).

You may have to initialize all 4 seat modules.

NOTE: The third-row seat is controlled by the second-row seat module.

Then proceed as follows:



1. Head restraint cannot be folded down:

NOTE: Raising the headrest back into the upright position must be done by pushing up on it by hand.

Can the head restraint be manually unlocked using the release loop beneath the headrest (see picture) and thus folded down?

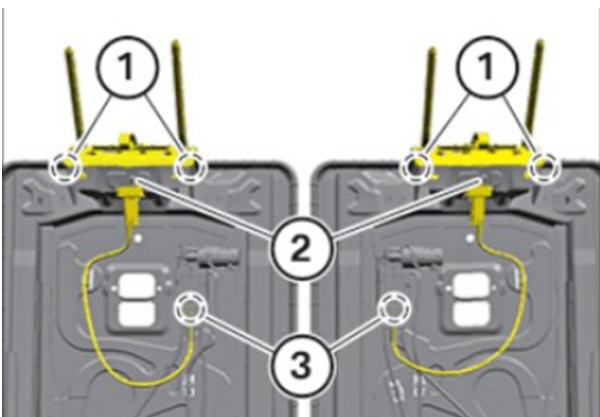

YES = Head restraint mechanism is faulty. Determine root cause of Bowden cable not moving (see steps below). If the cable is moving fully but the headrest is not folding, then replace the folding module of the head restraint (#2 in picture).

See REP 52 30 118 Remove and install/replace folding module of left or right head restraint

NOTE: The head restraint cannot be removed without destroying the covering material. **A new cover (leather) will be required to perform this repair.**

NO = Check if the Bowden cable is correctly mounted and properly routed.

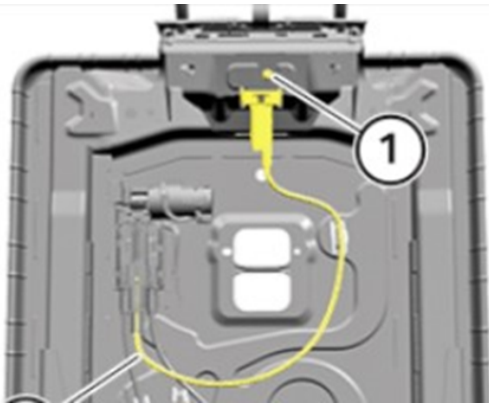

If the Bowden cable is mounted properly and cable correctly routed and the electric motor moving the common housing pulls all 3 Bowden cables equally but the headrest Bowden cable does not travel far enough, replace the Bowden cable for the headrest (shown in yellow in picture).

See REP 52 30 253 Replace Bowden cable for left or right head restraint (Bowden cable unlocking device for head restraint).

2. Third-row seating cannot be folded down:

Check if the latch (the fastener on the left or right side) of the third row of seats is open or closed? (this is the hook/pin shown in green in picture)

As a quick check for this, proceed as follows:

Fold the rear seat backrest of the third row of seats including the head restraint into seating position.

If the head restraint stays in the seat position, the latch is closed.

If the head restraint falls into the folded position again, the latch is open.

YES (Latch is open) = Replace drivetrain of backrest tilt adjustment.

See REP 67 31 635 Remove and install/replace drivetrain for backrest tilt adjustment of third-row seating (left or right) (according to vehicle diagnosis)

NOTE: If the seat was moved manually with excessive force, it may cause damage to the internal gear of this actuator. The motor may spin but the seat backrest may not move. In this case replacement of the drivetrain for backrest tilt adjustment is needed and the seat frame would not need replacement.

NO (Latch is closed) = Check if the drivetrain for backrest release adjustment is broken?

NOTE: The 3 Bowden cables are housed in a common housing that moves along a worm gear assembly.

When the electric motor activates, it spins the worm gear to pull up on the housing so that all

G07 3rd Row Seat – Overview Picture.

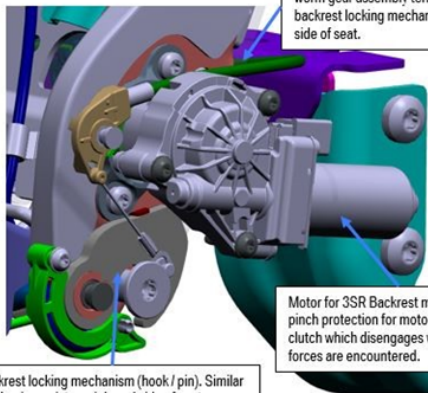

Bowden cable which originates at motor / worm gear assembly terminating at backrest locking mechanism on outboard side of seat.

Motor for 3SR Backrest movement. No pinch protection for motor, but has clutch which disengages when high forces are encountered.

Backrest locking mechanism (hook / pin). Similar mechanism exists on inboard side of seat.

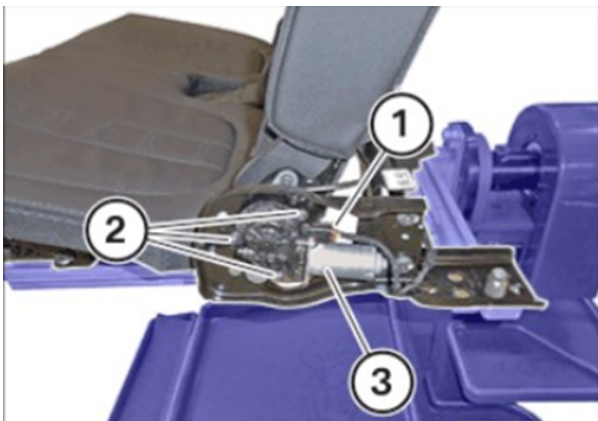

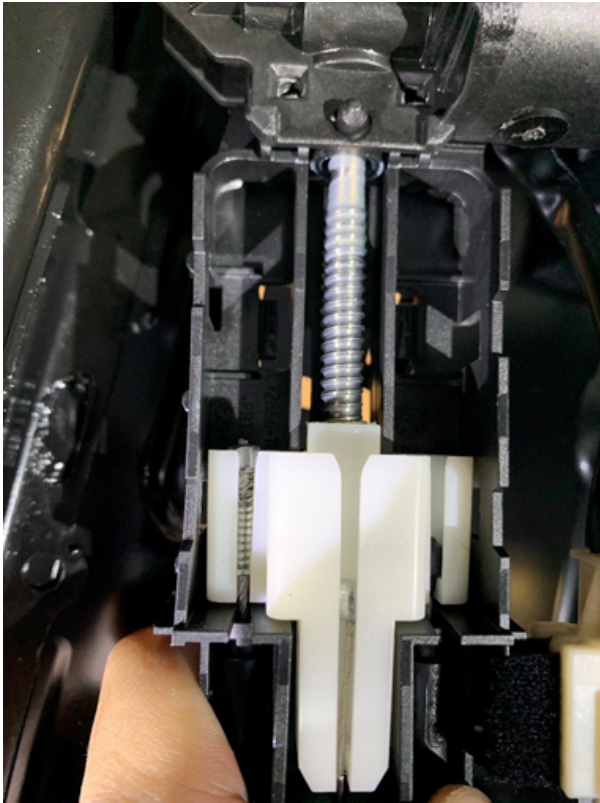

3 cables move simultaneously.

One of the cables controls the head restraint folding. Once pulled, the headrest will release and pivot downwards. **Raising the headrest back into the upright position must be done by pushing up on it by hand.**

(The other two cables control the latch release at the seat pivot to enable the seat to fold.)

For more details see either video:

- [B52 01 19](#) - G05/G07 Seat Troubleshooting 6 Passenger
- [B52 02 19](#) - G05/G07 Seat Troubleshooting 7 Passenger

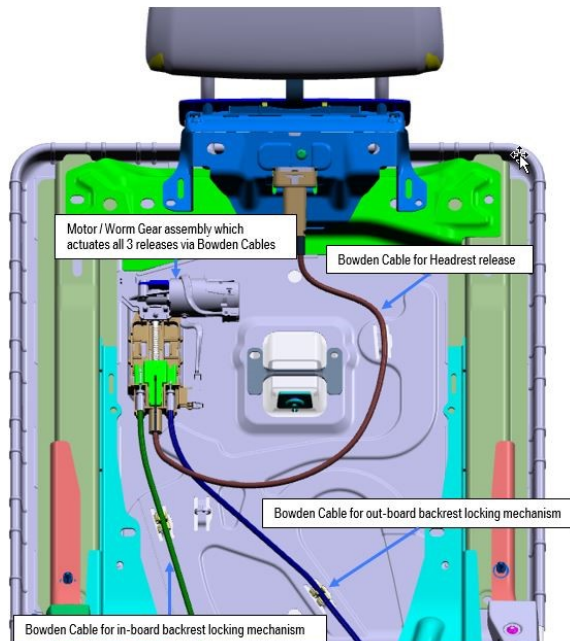

Is the drivetrain for the backrest release (actuator) broken?

YES = Replace only the drivetrain for backrest release (actuator).

See REP 67 31 645 Remove and install/replace drivetrain for backrest release of third-row seating (left or right) (according to vehicle diagnosis)

NO = Replace BOTH the Bowden cable(s) and drivetrain for backrest release (actuator).

See appropriate repair instruction:
 REP 52 30 256 Replace Bowden cable for left or right rear seat backrest (Bowden cable for outer backrest release)

REP 52 30 255 Replace Bowden cable for left or right rear seat backrest (Bowden cable for inner backrest release)

REP 67 31 645 Remove and install/replace drivetrain for backrest release of third-row seating (left or right) (according to vehicle diagnosis)

Then re-evaluate the vehicle.

PARTS INFORMATION

Obtain and confirm the part numbers for your specific vehicle by entering the chassis number in either ETK or AIR which considers specific equipment and/or options.

Copyright ©2023 BMW of North America, Inc.

This is an overview list of parts that may be required to make these repairs. You will only need one or more of these parts to repair the vehicle.

Part Number	Description	Quantity
52 30 7 485 444	Bowden Cable Unlocking	2
52 20 9 473 697	Actuator backrest folding	1
52 20 9 473 695	Drive backrest folding left	1
52 20 9 473 696	Drive backrest folding right	1
52 30 5 A1E 228	Bowden cable actuator left	1
52 30 5 A1E 229	Bowden cable actuator right	1
52 30 7 941 595	Headrest leather rear (schwarz)	2
52 30 7 941 592	Headrest leather rear (Beige)	2
52 30 9 496 669	Folding module head rest	1

CLAIM INFORMATION

This Service Information Bulletin provides technical, diagnostic and/or repair-related information.

Damage and/or issues caused by outside influences are not covered under the BMW limited warranties.

Eligible and Covered Work/Repairs

When used to repair a verified defect in materials or workmanship, the applicable repair procedure information that is provided in this bulletin is covered under the terms of the BMW New Vehicle Limited Warranty for Passenger Cars and Light Trucks.

To submit a claim, please following the established and applicable warranty policy and procedures (Labor/Part/Sublet – bulk materials/qualifying third-party repairs) that apply to the repair being performed.

Refer to AIR for the claim-related line item's Repair Code. For the corresponding repair that was performed, obtain the flat rate labor operation codes (*including the diagnosis that applies) and their corresponding flat rate unit (FRU) allowances.

Only one Main labor operation code can be claimed per repair visit.

*Based on which one applies to your center, please refer to **SI B01 01 20** or **B01 07 20** for the applicable procedure for documenting, claiming, and explaining, on the RO and in the claim comments, your diagnosis work time (WT), job/repair work time (WT), and the vehicle repairs your center performed, unless otherwise required by State law.

FEEDBACK REGARDING THIS BULLETIN

Technical Feedback	To submit feedback for the technical topic of this bulletin: Submit your feedback in the rating box at the top of this bulletin
Warranty Feedback	To submit feedback for the CLAIMS section of this bulletin: Submit an IDS ticket to the Warranty Department, or use the chat available in the Warranty Documentation Portal
Parts Feedback	To submit feedback for the PARTS section of this bulletin: Submit an IDS ticket to the Parts Department

Supporting Materials

Videos

[52 01 19](#)

[52 02 19](#)

