



Emissions Service Action

Code: 20DZ

Subject	EVAP Purge Valve and Hose Assembly				
Document History	Date		Summary		
	08/15/2023		Original publication		
Affected Vehicles	Country	Beginning Model Year	Ending Model Year	Vehicle	Vehicle Count
	USA	2019	2019	JETTA	168
Problem Description	<p>The EVAP purge valve with hose assembly installed in affected vehicles during service has not been tested or homologated with the current Engine Control Module (ECM) software. This issue has no impact to tailpipe or evaporative emissions.</p>				
Corrective Action	Install the correct EVAP purge valve with hose assembly.				
Code Visibility	On or about August 15, 2023, the campaign code will be applied to affected vehicles.				
Owner Notification	Owner notification will take place in August 2023. The owner letter example is included in this bulletin for your reference.				
Emissions Campaigns Requirements (CALIFORNIA ONLY)	<p>The California Air Resources Board and the Department of Motor Vehicles (DMV) require emissions-related campaigns to be completed prior to vehicle registration renewal. When campaign work is done you must provide the owner with a signed "Vehicle Emission Recall – Proof of Correction" certificate (RC EMISCAVWAU). Order certificates online via the Compliance Label Ordering portal at www.vwclub.com.</p>				
Additional Information	<p>Please alert everyone in your dealership about this action, including Sales, Service, Parts and Accounting personnel. Contact Warranty if you have any questions.</p> <p>Dealers must ensure that every affected inventory vehicle has this campaign completed <u>before delivery to consumers</u>.</p> <p>Fill out and affix Campaign Completion Label (CAMP 010 000) after work is complete. Labels can be ordered at no cost via the Compliance Label Ordering portal at www.vwclub.com.</p>				

Parts Information

Criteria	Quantity	Part Number	P.O.C. Part Description	Ordering Method (see description below)
01	1	04E-133-366-FH	HOSE	Free Order
	1	04E-133-723-GA	FUEL LINE	
	4	036-129-717-E	GASKET	
	1	N -909-865-01	CLIP	
	1	WHT-003-247	WASHER	
	1	WHT-001-386	GASKET	
	3	WHT-000-729-A	BOLT	
	1	G -12E-100-1G CON	COOLANT (concentrate)	

Parts Control Type: Free Order	Parts will be managed by Free Order
---	-------------------------------------

Initial Allocation: NO	There will be no parts allocation. Please reference the Repair Projection Tool (below) to view your potential VIN population.
---	---

Repair Projection Tool: (right click to open)	
--	--

NOTE

Campaign parts should always be ordered as per the parts information in this circular. The ordering system will supersede the part, if applicable.

Claim Entry Instructions

The labor times listed here may differ from the labor operations and labor times listed in ELSA.

After campaign has been completed, enter claim as soon as possible to help prevent work from being duplicated elsewhere. Attach the ELSA screen print showing action open on the day of repair to the repair order.

If customer refused campaign work:

- ✓ U.S. dealers: Submit request via WISE under the *Campaigns/Update/Recall Closure* option.

Service Number	20DZ		
Damage Code	0099		
Parts Vendor Code	WWO		
Claim Type	Sold vehicle: 7 10 Unsold vehicle: 7 90		
Causal Indicator	Mark HOSE* as causal part		
Vehicle Wash/Loaner	Do not claim wash/loaner under this action U.S.A.: Loaner/rental coverage cannot be claimed under this action. However, loaner/rental may be covered under the Alternate Transportation Program. Please refer to the Volkswagen Warranty Policy and Procedures Manual for loaner claims information and reimbursement details.		
Criteria I.D.	01		
	Remove intake manifold and replace EVAP hose with purge valve		
	LABOR		
	Labor Op	Time Units	Description
	2022 19 65	SEE ELSA	Activated charcoal filter pipe remove+reinstall
	2447 19 15	SEE ELSA	Intake manifold remove+reinstall
	<i>Add the following labor operation ONLY if MIL was on and faults were stored for EVAP leaks:</i>		
	0150 00 00	Time stated on diagnostic protocol	Clear repair-related faults
	PARTS		
	Quantity	Part Number	Description
	1.00	04E133366FH	HOSE*
	4.00	036129717E	GASKET
	1.00	04E133723GA	FUEL LINE

Continued on next page

PARTS (continued)		
Quantity	Part Number	Description
Up to 40.00	G 12E100S1	COOLANT CONCENTRATE
1.00	N 90986501	CLIP
3.00	WHT000729A	BOLT
1.00	WHT001386	GASKET
1.00	WHT003247	WASHER

The information in this document is intended for use only by skilled technicians who have the proper tools, equipment and training to correctly and safely maintain your vehicle. These procedures are not intended to be attempted by "do-it-yourselfers," and you should not assume this document applies to your vehicle, or that your vehicle has the condition described. To determine whether this information applies, contact an authorized Volkswagen dealer. ©2023 Volkswagen Group of America, Inc. All Rights Reserved.

Customer Letter Example (USA)

<MONTH YEAR>

<CUSTOMER NAME>

<CUSTOMER ADDRESS>

<CUSTOMER CITY STATE ZIPCODE>

This notice applies to your vehicle: <MODEL YEAR> <BRAND> <CARLINE>, <VIN>

Subject: Emissions Service Action 20DZ - EVAP Purge Valve and Hose Assembly

Dear Volkswagen Owner,

In cooperation with the United States Environmental Protection Agency and the California Air Resources Board, we are informing you of our decision to conduct an emissions service action on certain 2019 model year Volkswagen vehicles. Our records show that you are the owner of a vehicle affected by this action.

What is the issue?	The EVAP purge valve with hose assembly installed in affected vehicles during service has not been tested or homologated with the current Engine Control Module (ECM) software. This issue has no impact to tailpipe or evaporative emissions.
What will we do?	Your authorized Volkswagen dealer will install the correct EVAP purge valve with hose assembly. This work will take about three hours to complete and will be performed for you free of charge. Please keep in mind that your dealer may need additional time for the preparation of the work, as well as to accommodate their daily workshop schedule.
What should you do?	Please contact your authorized Volkswagen dealer as soon as possible to schedule this work. To set up an appointment online, please visit www.vw.com/find-a-dealer .
Lease vehicles and address changes	If you are the lessor and registered owner of the vehicle identified in this action, please forward this letter immediately via first-class mail to the lessee within ten (10) days of receipt. If you have changed your address or sold the vehicle, please fill out the enclosed prepaid Owner Reply card and mail it to us so we can update our records.
Important information for California Vehicle Owners – <u>California Regulations</u>	California regulations require that this campaign be completed prior to the time you renew your vehicle registration. Therefore, please make sure that this campaign is completed prior to the renewal of your vehicle registration , and that you furnish proof of completion to the Department of Motor Vehicles (DMV) in the form of a copy of the dealer's repair order, including a signed "Proof of Correction" certificate. You obtain this from your dealer after the campaign has been completed. Please retain the signed "Proof of Correction Certificate" with your vehicle records. DO NOT MAIL THIS FORM to the DMV, unless requested.
Can we assist you further?	If your authorized Volkswagen dealer fails or is unable to complete this work free of charge within a reasonable time, or if you should have any questions about this communication, please reach out to us using your preferred method of communication at www.vw.com/contact or by calling us at 800-893-5298.

We apologize for any inconvenience this matter may cause; however we are taking this action to help ensure your vehicle continues to meet and exceed your expectations.

Sincerely,

Volkswagen Customer Protection

Repair Overview

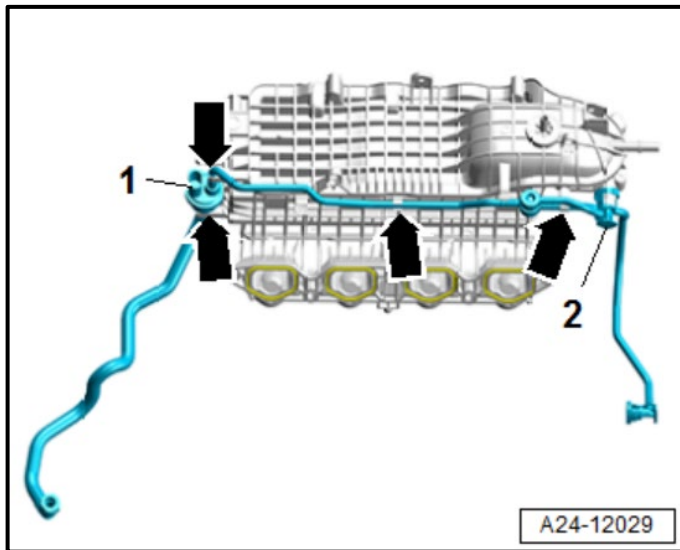

- Replace EVAP Canister Purge Regulator Valve 1 -N80- with connecting pipe.

! NOTE

- These repair instructions may differ from the labor operations and labor times listed in ELSA.
- Damages resulting from improper repair or failure to follow these work instructions are the dealer's responsibility and are not eligible for reimbursement under this action.
- This procedure must be read in its entirety prior to performing the repair.
- Due to variations in vehicle equipment and options, the steps/illustrations in this work procedure may not identically match all affected vehicles.
- Diagnosis and repair of pre-existing conditions in the vehicle are not covered under this action.
- When working during extreme temperatures, it is recommended that the vehicle be allowed to acclimate inside the shop to avoid temperature-related component damage/breakage.

Required Tools

 <p>Hose Clamps - Up To 25mm -3094- (or equivalent)</p>	 <p>Hose Clip Pliers -VAS6362- (or equivalent)</p>
 <p>Intake Manifold Release Tool -T10527-</p>	 <p>Engine Bung Set -VAS6122- (or equivalent)</p>



The information in this document is intended for use only by skilled technicians who have the proper tools, equipment and training to correctly and safely maintain your vehicle. These procedures are not intended to be attempted by "do-it-yourselfers," and you should not assume this document applies to your vehicle, or that your vehicle has the condition described. To determine whether this information applies, contact an authorized Volkswagen dealer. ©2023 Volkswagen Group of America, Inc. All Rights Reserved.

Repair Instruction

Section A - Check for Previous Repair

TIP

If Campaign Completion label is present, no further work is required.

Applicable criteria ID(s)	Campaign/Action Status
01 	Open 

EXAMPLE

Campaign/Action	Start	Designation
	2015-11-10	W-SERV_ACT -
	2018-12-13	RECALL -
	2017-05-16	A-RECALL -



EXAMPLE

- Enter the VIN in Elsa and proceed to the “Campaign/Action” screen.

TIP

On the date of repair, print this screen and keep a copy with the repair order.

- Confirm the Campaign/Action is open <arrow 1>. If the status is closed, no further work is required.
- Note the Applicable Criteria ID <arrow 2> for use in determining the correct work to be done and corresponding parts associated.

CRITICAL REPAIR STEP



If multiple software update Campaign/Actions are open, they must be performed in order of the Start date <arrow 3>. The oldest should be performed first.

- **All Safety Recalls must be completed prior to completing this campaign.**
- **Proceed to Section B.**

Section B – Repair Procedure

NOTE

If MIL is on at the time the 20DZ is performed and the stored faults are related to a faulty EVAP Canister Purge Regulator Valve 1 -N80-, the time to check and clear the faults using ODIS/GFF can be accounted for under the 20DZ.

Diagnosis and repair of faults not related to this action cannot be charged against the 20DZ.

Remove air filter housing:

- Loosen the front screw-type clamp <arrow> on the connection <1> on the air filter housing <2>.
- Remove the air duct hose <3>.

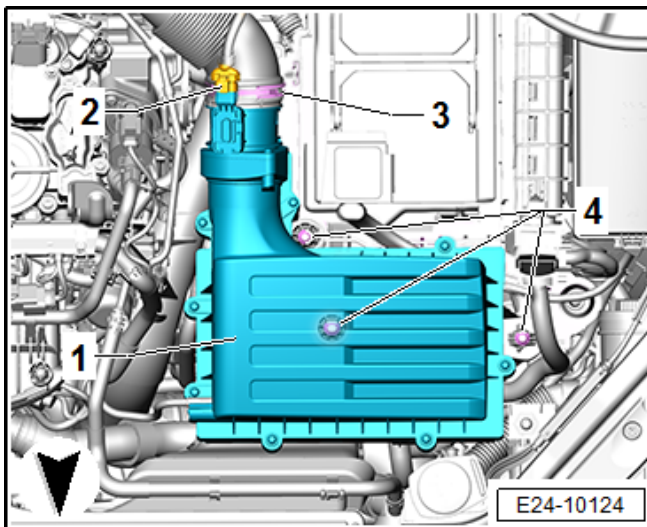
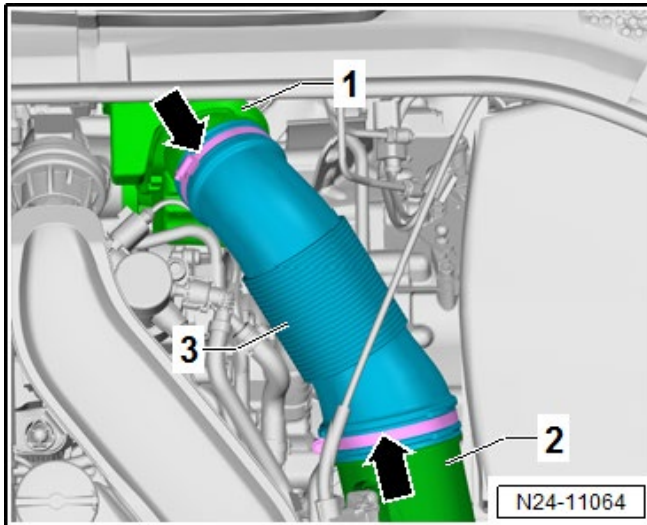

- If equipped, release and remove the connector <2> for the Mass Airflow Measurement Module -GX35-.
- Loosen the hose clamp <3> and remove the air duct hose.
- Pull the air filter housing <1> upward off of the ball pins <4>.

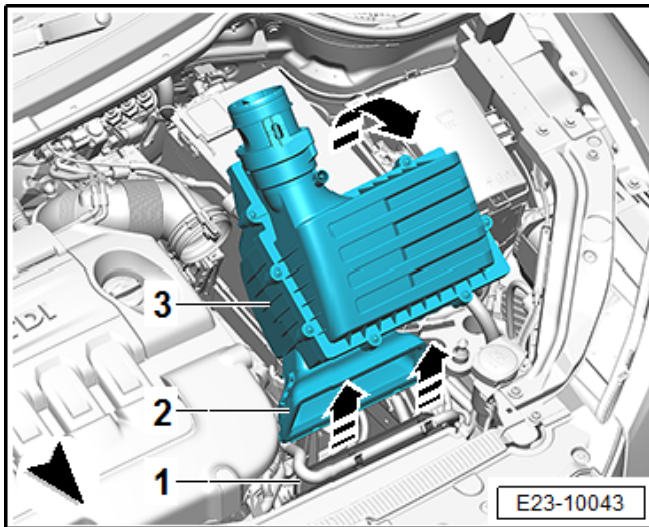

- Pivot the air filter housing <3> rearward in the direction of <arrow>. At the same time remove the air duct <2> from the air duct <1>.

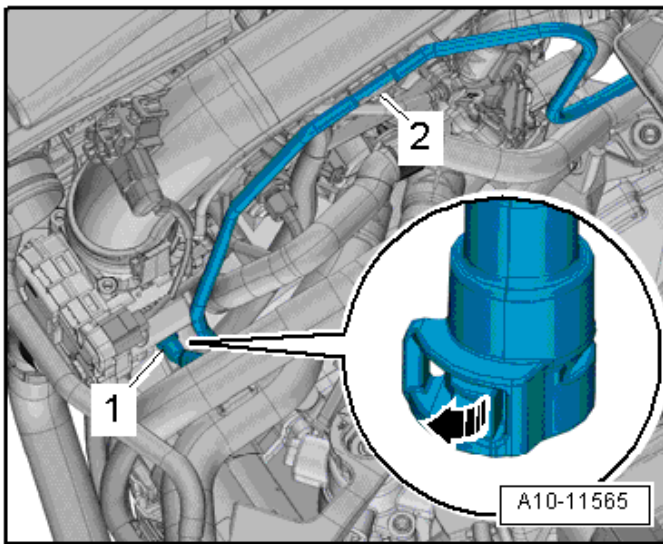

Free up vacuum hose:

- Open the retainer in direction of <arrow> and remove the vacuum hose <1> using a pick tool, for example
- Free up the vacuum hose on the air duct pipe <2>.

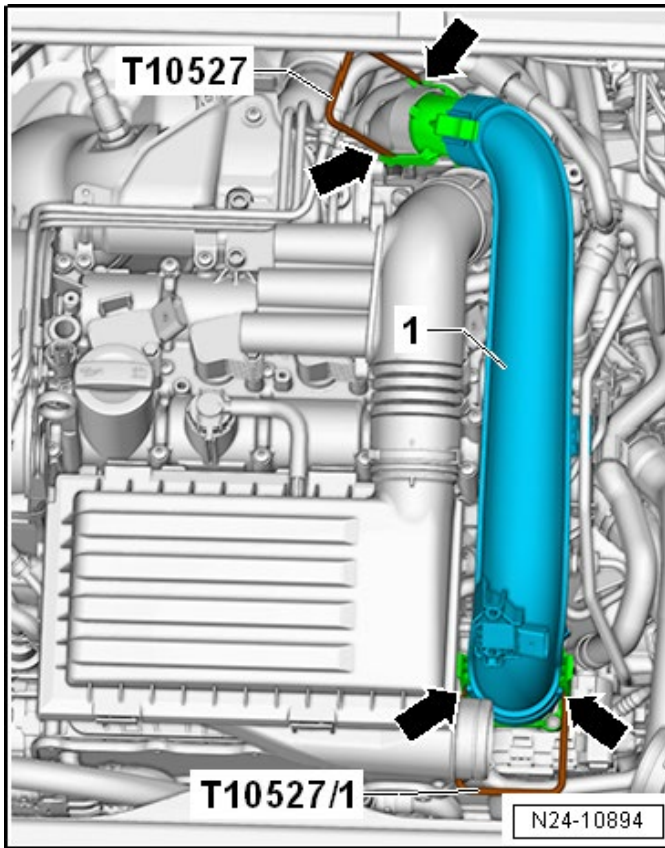

Remove air duct pipe:

CAUTION

Risk of Consequential Damage

Use extreme care when releasing the retainers for the air duct pipe.

Avoid rocking the air duct pipe back and forth when removing.

- Free up all hose connections from the air duct pipe.
- Remove the connector from the Charge Air Pressure Sensor -GX26-.
- Release the retainers <arrows> using the -T10527- and -T10527/1-.
- Seal the open connections with clean plugs from the -VAS6122- .

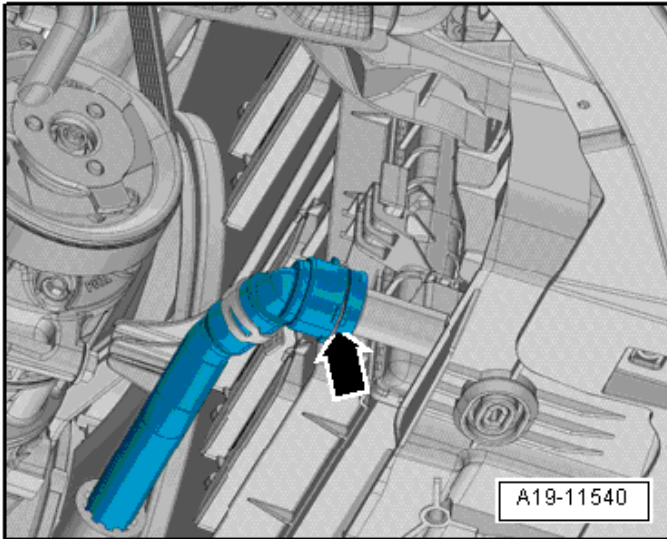

Drain engine coolant:

⚠ CAUTION

The cooling system is under pressure when the engine is warm. Risk of scalding due to hot steam and hot coolant.

Scalding the skin and other parts of the body is possible.

- Wear safety gloves.
 - Wear protective eyewear.
 - Reduce the pressure by covering the coolant expansion tank cap with a cloth and carefully opening it.
-
- Remove noise insulation.
 - See ELSA Repair Manual: *Repair manual > Body Exterior > 66 Exterior Equipment > Noise Insulation > Noise Insulation, Removing and Installing, Gasoline Engine*
 - Drain the coolant:
 - See ELSA Repair Manual: *Repair manual > Engine > 4-Cylinder Fuel Injection Engine (1.4L Engine, 4V, EA211, Turbocharger) > 19 Cooling System > Coolant System/Coolant > Coolant, Draining and Filling*

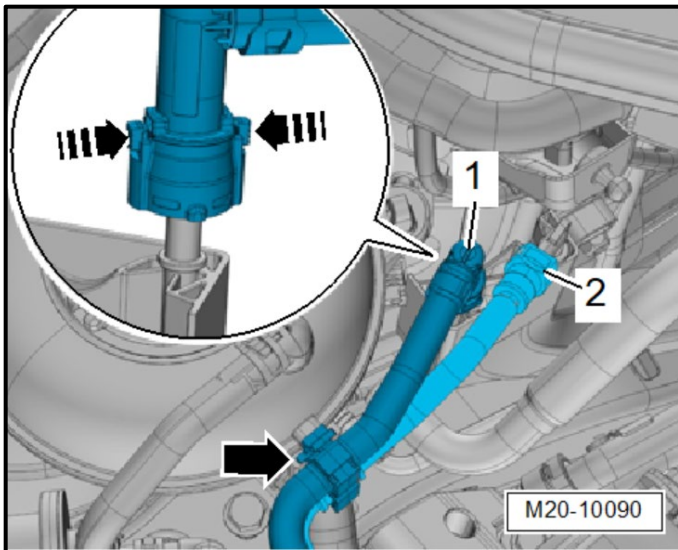

Disconnect fuel supply line and EVAP hose:

CAUTION

**The fuel system is under pressure.
Risk of injury from fuel spraying out.**

- Wear protective eyewear.
- Wear safety gloves.
- Reduce the pressure: place clean cloths around the connection point and carefully open the connection point.

CAUTION

Risk of injury from fuel spraying out.

If the front door is opened, the fuel pump will activate. This will result in fuel leaking when the fuel system is opened.

Do not open the front door or turn the ignition on when the fuel system is opened.

- Remove the hose from the coolant reservoir tank and free it up in direction of <arrow>.
- Push the fuel hose coupling <1> downward and then press the release buttons <arrows>.
- Remove the fuel hose coupling upwards with the release buttons pressed.
- Press the release button on the EVAP canister hose <2> and remove hose.

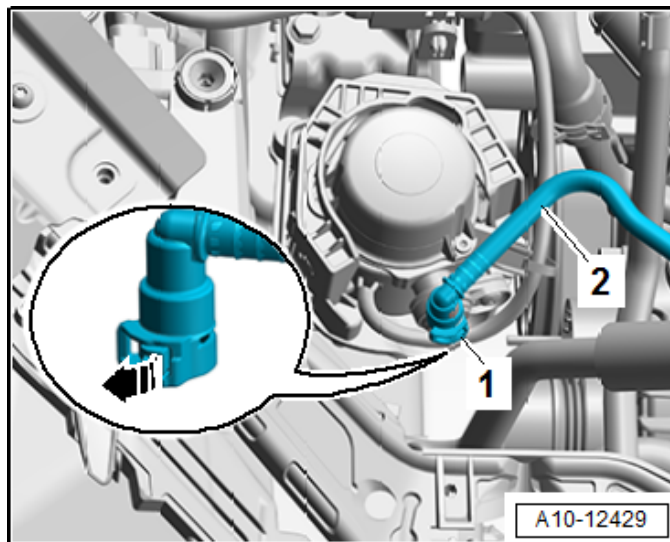

Disconnect vacuum hose:

- Release the retainer <1> in direction of <arrow>, remove the vacuum hose <2> and free it up.

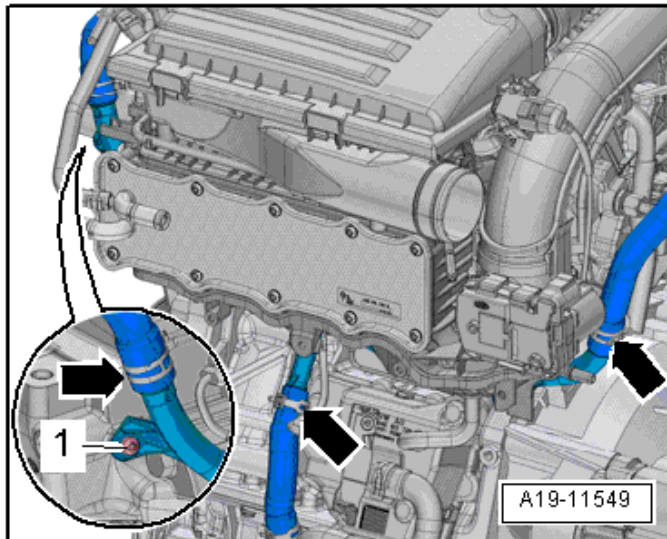

Prepare intake manifold for removal:

- Remove the bolt <1> and loosen the clamps <arrows>.
- Remove the coolant hoses.

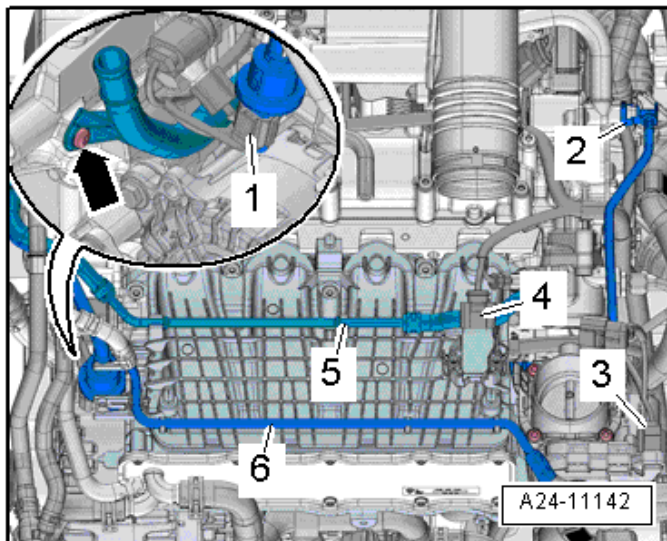

- Disconnect the connectors:
 1. For EVAP Canister Purge Regulator Valve 1 -N80-
 2. For the Throttle Valve Control Module -GX3-
 3. For Intake Manifold Sensor -GX9-
- Ignore the <arrow> in the image.
- Press the release buttons and remove the EVAP canister hose <2>.
- Unclip the fuel supply line <5> and the coolant line <6> from the intake manifold and move them to the side.

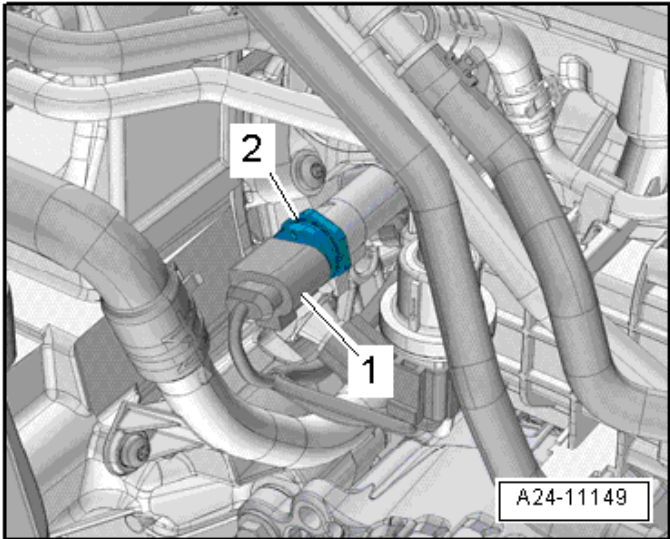

- Disconnect the connector <1> from the Fuel Pressure Sensor -G247-.
- Disconnect the connector from the oil pressure switch.

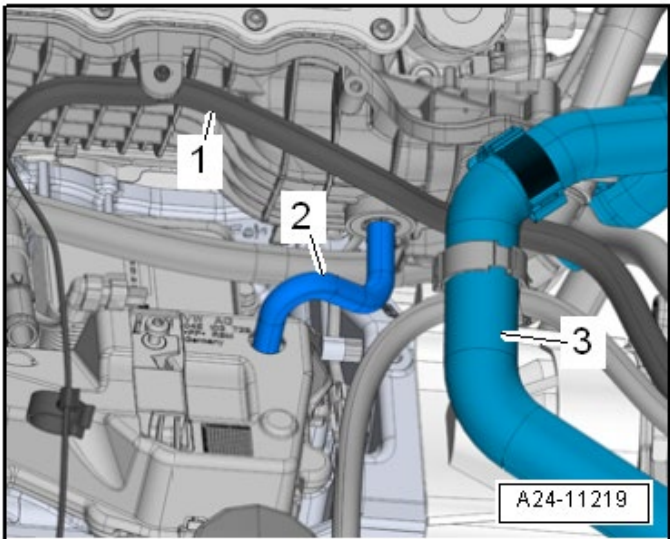

- Free up the wiring harness <1> and coolant hose <3> on the intake manifold.
- Carefully remove the crankcase ventilation hose <2>.

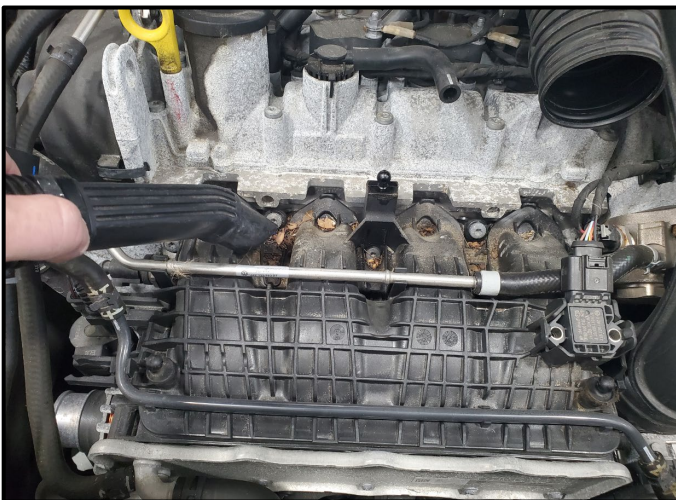

- Vacuum any debris that has accumulated on top of the intake manifold

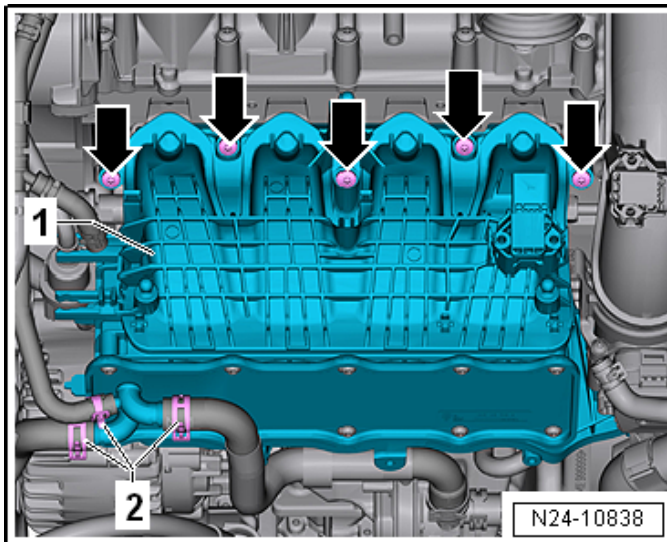

Remove intake manifold:

- Loosen the clamps <2> and remove the coolant hoses.
- Remove the bolts <arrows>.
- Remove the intake manifold <1>.



Seal openings:

- Seal openings in cylinder head with clean, lint free shop rags.

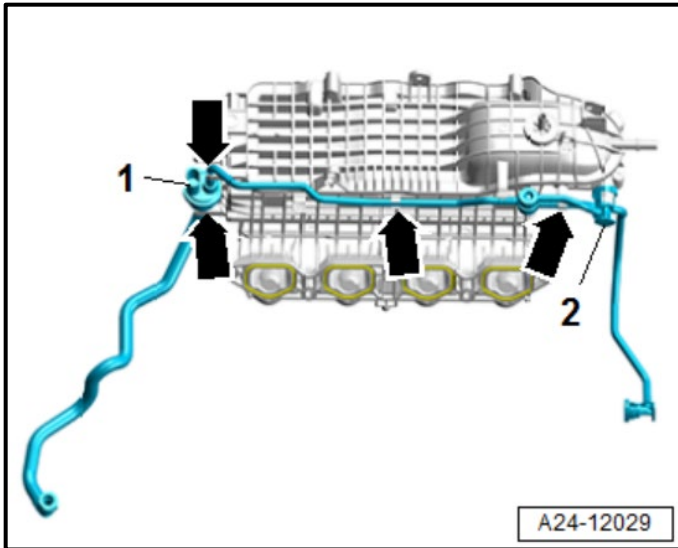

Replace EVAP Canister Purge Regulator Valve 1 -N80- with connecting pipe:

- Unclip the EVAP Canister Purge Regulator Valve 1 -N80- with the connecting pipe from the retainers <arrow> on the intake manifold.
- Press the release buttons on the quick connector <2>, disconnect the EVAP Canister Purge Regulator Valve 1 -N80- <1> with the connecting pipe from the intake manifold and remove it.
- Install new EVAP Canister Purge Regulator Valve 1 -N80- with connecting pipe in reverse order of removal.

Part Number	Part Description
04E-133-366-FH	EVAP Canister Purge Regulator Valve 1 -N80- with connecting pipe

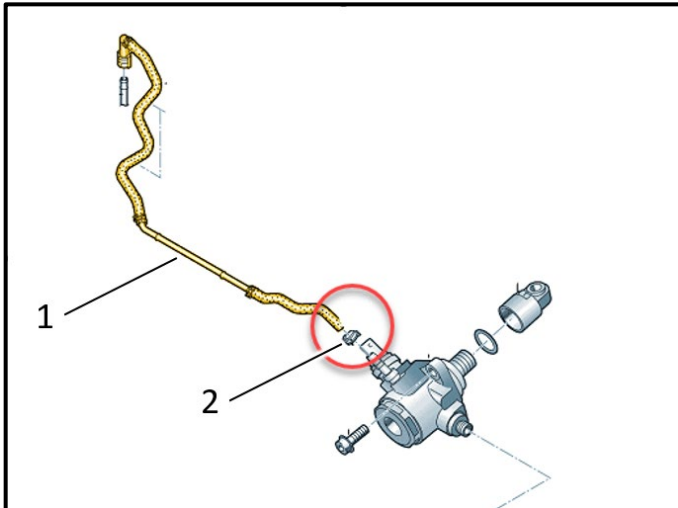

Replace fuel supply hose:

- Replace fuel supply hose <1> and clamp <2>.

Part Number	Part Description
04E-133-723-GA	Fuel Supply Hose
N -909-865-01	Clamp

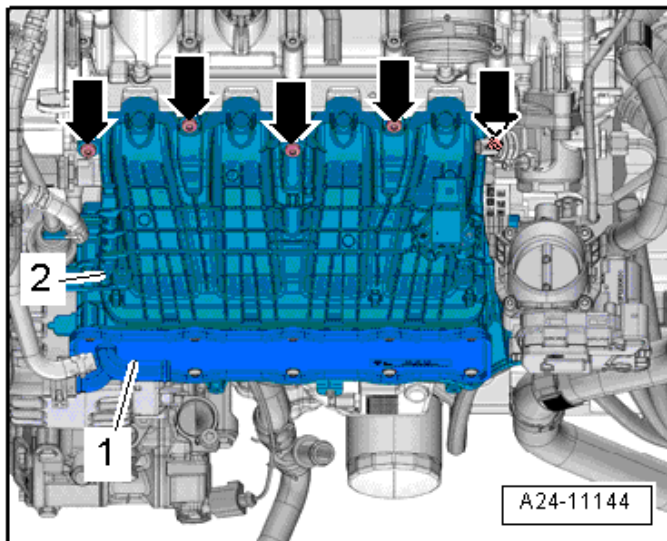

Installation of components is the reverse order of removal:

- Replace the intake manifold seals.

Part Number	Part Description
036-129-717-E	Intake Manifold Seals (x4)

- Tighten the bolts <arrows> in stages as follows:
 1. Starting in the center and alternating from side to side, install by hand all the way in.
 2. Starting from the center and alternating from side to side, torque to 8 Nm.

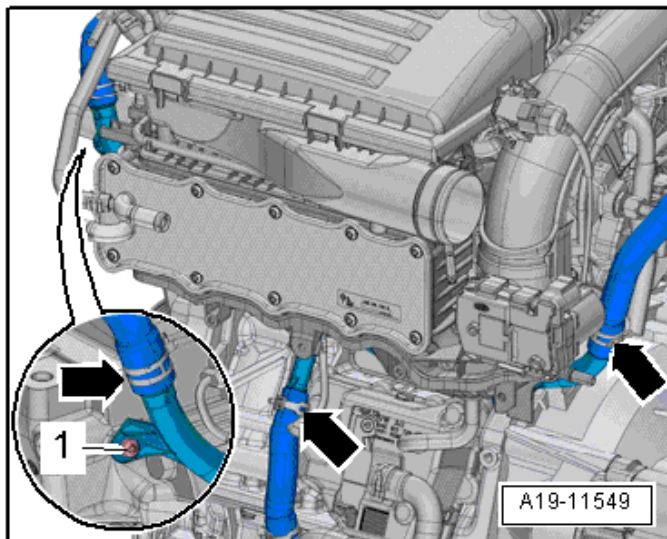

- Reconnect coolant hoses and EVAP hoses.
- Ensure coolant hose clamps are positioned correctly.
- Torque coolant pipe bolt <1> to 8 Nm.

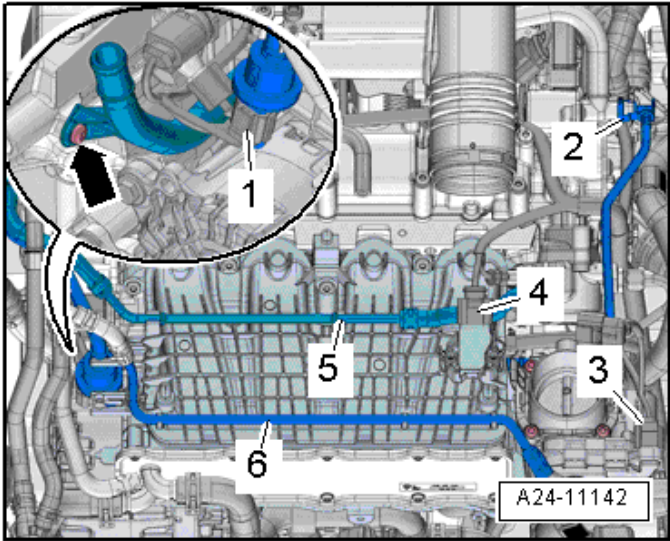

- Reconnect all electrical connectors.
- Secure fuel supply line and coolant line.

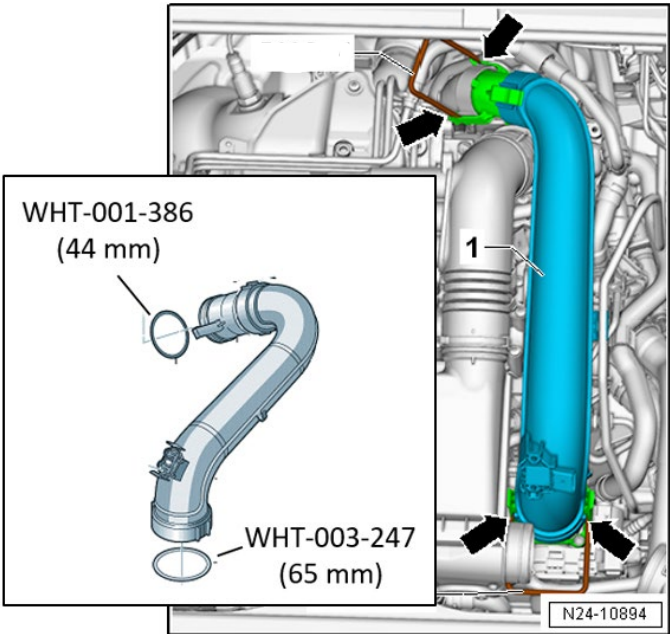

⚠ CAUTION

Risk of Consequential Damage
 Use extreme care when reinstalling the air duct pipe.
 Avoid rocking the air duct pipe back and forth when installing.

- Replace air duct pipe O-rings.

Part Number	Part Description
WHT-001-386	44 mm O-ring
WHT-003-247	65 mm O-ring

- Coat O-rings lightly with clean engine oil before installing air duct pipe <1>.
- Ensure the contact area for the air duct pipe in the turbo inlet is clean.
- Ensure locking retainers <arrows> are fully engaged.

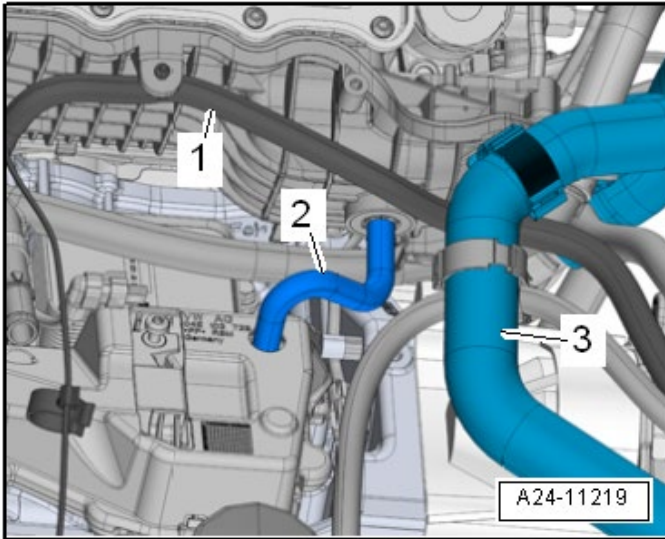

- Secure wiring harness <1> and coolant hose <3> on the intake manifold.
- Install the crankcase ventilation hose <2>.

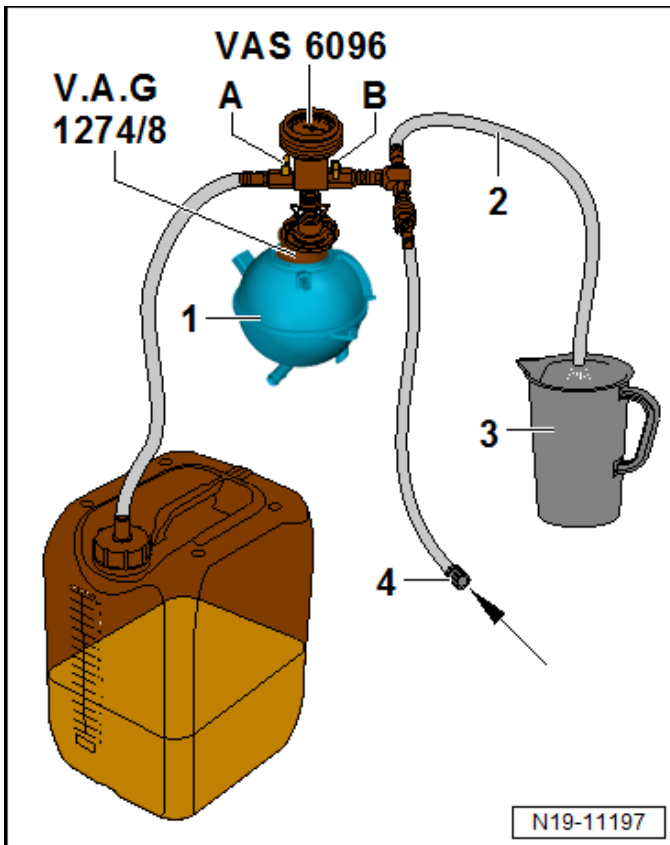

Fill coolant:

- See ELSA Repair Manual: *Repair manual > Engine > 4-Cylinder Fuel Injection Engine (1.4L Engine, 4V, EA211, Turbocharger) > 19 Cooling System > Coolant System/Coolant > Coolant, Draining and Filling*
- Install noise insulation in the reverse order of removal.
 - Torque noise insulation screws to 2 Nm.
 - Replace M8 bolts and torque to 6 Nm.

Part Number	Part Description
WHT-000-729-A	BOLT

Proceed to Section C

Section C – Campaign Completion Label

Install Campaign Completion Label

- Fill out and affix Campaign Completion Label, part number CAMP 010 000, next to the vehicle emission control information label.



Ensure Campaign Completion Label does not cover any existing label(s).

Proceed to Section D

Section D - Parts Return/Disposal

Properly store (retain), destroy or dispose of removed parts in accordance with all state/province and local requirements, unless otherwise indicated and/or requested through the Warranty Parts Portal (WPP).

Proceed to Section E (California only).

Section E – California Only Requirements

CALIFORNIA ONLY Requirements for Emissions Campaigns Having Customer Notification

The California Air Resources Board and the Department of Motor Vehicles (DMV) require emissions-related campaigns to be completed prior to vehicle registration renewal. **When campaign work is done you must provide the owner with a signed “Vehicle Emission Recall – Proof of Correction” certificate (RC EMIS_CAL VW).** Certificates can be ordered at no cost online via the Compliance Label Ordering portal at www.vwhub.com.



Ensure owners are aware of the importance of retaining the completed certificate for their records. It should be mailed to the California DMV only upon request.