



# Service Action

## Code: 34K1

<b>Subject</b>	<b>Transmission Control Module (TCM) Software</b>																			
<b>Document History</b>	<table border="1"> <thead> <tr> <th>Date</th> <th>Summary</th> </tr> </thead> <tbody> <tr> <td>08/03/2023</td> <td>Original publication</td> </tr> </tbody> </table>		Date	Summary	08/03/2023	Original publication														
Date	Summary																			
08/03/2023	Original publication																			
<b>Affected Vehicles</b>	<table border="1"> <thead> <tr> <th>Country</th> <th>Beginning Model Year</th> <th>Ending Model Year</th> <th>Vehicle</th> <th>Vehicle Count</th> </tr> </thead> <tbody> <tr> <td>USA</td> <td>2018</td> <td>2018</td> <td>GOLF R</td> <td>310</td> </tr> <tr> <td>CAN</td> <td>2018</td> <td>2018</td> <td>GOLF R</td> <td>63</td> </tr> </tbody> </table>					Country	Beginning Model Year	Ending Model Year	Vehicle	Vehicle Count	USA	2018	2018	GOLF R	310	CAN	2018	2018	GOLF R	63
Country	Beginning Model Year	Ending Model Year	Vehicle	Vehicle Count																
USA	2018	2018	GOLF R	310																
CAN	2018	2018	GOLF R	63																
	<p>Check Campaigns/Actions screen in ELSA on the day of repair to verify that a VIN qualifies for repair under this action. ELSA is the <u>only</u> valid campaign inquiry &amp; verification source.</p> <ul style="list-style-type: none"> <li>✓ Campaign status must show "open."</li> <li>✓ If ELSA shows other open action(s), inform your customer so that the work can also be completed at the same time the vehicle is in the workshop for this campaign.</li> </ul>																			
<b>About this Service Action</b>	Volkswagen is providing updated transmission control module (TCM) software to enhance an in-vehicle alert should a problem arise within the auxiliary hydraulic pump. Additionally, if a specific fault is found after the software is updated, a repair will be made to the transmission.																			
<b>Code Visibility</b>	On or about August 03, 2023, the campaign code will be applied to affected vehicles.																			
<b>Owner Notification</b>	Owner notification will take place in August 2023. Owner letter examples are included in this bulletin for your reference.																			
<b>Campaign Expiration Date</b>	This campaign expires on <b>December 31, 2026</b> . Repairs must be performed on or before this date to be eligible for payment. Keep this expiration date in mind when scheduling customers for this action. If a customer wishes to have this service performed after the expiration date, your dealerships normal parts and labor cost associated with this repair will apply.																			
<b>Additional Information</b>	<p><b>Please alert everyone in your dealership about this action, including Sales, Service, Parts and Accounting personnel. Contact Warranty if you have any questions.</b></p> <p>Dealers must ensure that every affected inventory vehicle has this campaign completed <u>before delivery to consumers</u>.</p> <p>Fill out and affix Campaign Completion Label (CAMP 010 000) after work is complete. Labels can be ordered at no cost via the Compliance Label Ordering portal at <a href="http://www.vwhub.com">www.vwhub.com</a>.</p>																			

## Parts Information

**Parts Control Type:**  
**Free Order**

Parts will be managed by Free Order

**Initial Allocation:**  
**NO**

There will be no parts allocation. Please reference the Repair Projection Tool (below) to view your potential VIN population.

**Repair Projection Tool:**  
**(right click to open)**



Criteria	Quantity	Part Number	P.O.C. Part Description	Ordering Method	
01	2	01M-323-255	SEAL RING (o-ring for driveshaft)	Free Order	
	1	06B-105-313-D	BEARING (needle bearing – confirm part number in ETKA)		
	1	0BH-325-147	CLIP (for mechatronic connector)		
	1	0GC-398-008-D	REPSET (repair kit)		
	1	0GC-927-377	GASKET (seal for mechatronic connector) (if damaged)		
	1	1K0-253-141-AA	CLAMP (exhaust clamp)		
	2	7E0-407-297	RING (driveshaft circlip)		
	1	D -174-003-M2	SEALANT		
	0.1	G -055-128-A1	SEAL GREASE (for axle seal installation)		
	Up to 1	G -12E-100-1G CON	COOLANT		<b>USA ONLY</b>
	Up to 1	G -12E-100-2G CON	COOLANT		<b>CANADA ONLY</b>
	7	G -055-529-A2	GEAR OIL		
	2	N -015-081-6	NUT (coupling rod)		
	6	N -103-320-02	NUT (transverse link)		
	2	N -105-524-02	BOLT (steering rack)		
	3	N -105-524-04	BOLT (gearbox mounting)		
	1	N -107-847-01	BOLT (pendulum support)		
1	N -107-848-01	SCREW (pendulum support)			
6	N -107-854-01	SCREW (assembly mounting)			

Continued on next page

Criteria	Quantity	Part Number	P.O.C. Part Description	Ordering Method
01	3	N -908-461-02	SCREW (front propshaft)	Free Order
	1	N -909-654-01	SCREW (drain plug)	
	6	N -909-911-02 or N -911-082-01	BOLT (driveshaft – confirm part number in ETKA)	
	4	N -910-669-01	BOLT (middle propshaft)	
	4	N -910-889-01	SCREW (bevel box)	
	1	N -912-010-01	BOLT (pendulum support)	
	4	N -912-312-01	SCREW (assembly mounting)	
	5	WHT-000-729-A	BOLT (noise insulation)	
	3	WHT-005-179	SCREW (rear propshaft)	

 **NOTE**

Campaign parts should always be ordered as per the parts information in this circular. The ordering system will supersede the part, if applicable.

## Claim Entry Instructions

The labor times listed here may differ from the labor operations and labor times listed in ELSA.

After campaign has been completed, enter claim as soon as possible to help prevent work from being duplicated elsewhere. Attach the ELSA screen print showing action open on the day of repair to the repair order.

If customer refused campaign work:

- ✓ U.S. dealers: Submit request via WISE under the *Campaigns/Update/Recall Closure* option.
- ✓ Canada dealers: Upload the repair order [signed by customer] to Volkswagen WIN/Operations/Campaign Closure.

<b>Service Number</b>	34K1		
<b>Damage Code</b>	0099		
<b>Parts Vendor Code</b>	WWO		
<b>Claim Type</b>	Sold vehicle: 7 10 Unsold vehicle: 7 90		
<b>Causal Indicator</b>	Mark labor as causal if fault does not store after the software update Mark REPSET* as causal if fault sets after software update		
<b>Vehicle Wash/Loaner</b>	Do not claim wash/loaner under this action  <b>U.S.A.:</b> Loaner/rental coverage cannot be claimed under this action. However, loaner/rental may be covered under the Alternate Transportation Program. Please refer to the Volkswagen Warranty Policy and Procedures Manual for loaner claims information and reimbursement details.  <b>Canada:</b> Loaner/rental coverage cannot be claimed under this action. Please refer to Volkswagen Service Loaner Program to determine loaner eligibility.		
<b>Criteria I.D.</b>	02		
	Update TCM software. Fault not stored after software update and road test.		
	<b>LABOR</b>		
	<b>Labor Op</b>	<b>Time Units</b>	<b>Description</b>
	2706 89 50	SEE ELSA	Connect battery charger
	0150 00 00	Time stated on diagnostic protocol (up to 50 TU)	Update TCM software
<b>AND (if necessary)</b>	Add only if fault P0C29 stored after software update and road test. Remove and install transmission. Replace auxiliary hydraulic pump and perform basic settings.		
	<b>LABOR</b>		
	<b>Labor Op</b>	<b>Time Units</b>	<b>Description</b>
	3435 19 42	SEE ELSA	Transmission remove+reinstall
	3435 42 99	380	Replace auxiliary hydraulic pump

Continued on next page

<b>PARTS</b>		
<b>Quantity</b>	<b>Part Number</b>	<b>Description</b>
1.00	0GC398008D	REPSET*
2.00	01M323255	ROUND SEAL
1.00	06B105313D	NEEDLE BEARING
1.00	0BH325147	RETAINING CLIP
1.00	0GC927377	GASKET
1.00	1K0253141AA	DUAL CLAMP
2.00	7E0407297	LOCK RING
1.00	D 174003M2	SILCONE SEALANT
0.10	G 055128A1	SEAL GREASE
Up to 40.00	G 12E100S1	COOLANT (concentrate)
7.00	G 055529A2	GEAR OIL
2.00	N 0150816	SHOULDERED HEX. NUT
6.00	N 10332002	SHOULDERED HEX. NUT
2.00	N 10552402	BOLT, HEX. HD. WITH SHOULDER
3.00	N 10552404	BOLT, HEX. HD. WITH SHOULDER
1.00	N 10784701	BOLT
1.00	N 10784801	SCREW
6.00	N 10785401	HEXAGON FLANGE SCREW (COMBI)
3.00	N 90846102	12 POINT SOCKET HEAD SCREW
1.00	N 90965401	PLUG WITH SEAL
6.00	N 90991102 or N 91108201	BOLT, WITH POLYGON SOCKET HD. (driveshaft bolts – confirm part number in ETKA)
4.00	N 91066901	BOLT, HEX. HD. WITH SHOUL (COMBI)
4.00	N 91088901	SOCKET HD. SCREW WITH COLLAR
1.00	N 91201001	BOLT, HEX, HD. (COMBI)
4.00	N 91231201	SCREW
5.00	WHT000729A	HEX SOCKET HEAD BOLT (COMBI)
3.00	WHT005179	12 POINT SOCKET HEAD SCREW

## Customer Letter Example (USA)

<MONTH YEAR>

<CUSTOMER NAME>

<CUSTOMER ADDRESS>

<CUSTOMER CITY STATE ZIPCODE>

**This notice applies to your vehicle:** <MODEL YEAR> <BRAND> <CARLINE>, <VIN>

**Subject: Service Action 34K1 - Transmission Control Module (TCM) Software**

Dear Volkswagen Owner,

As part of Volkswagen's ongoing commitment to customer satisfaction, we are informing you of our decision to conduct a service action on certain 2018 model year Volkswagen Golf R vehicles. Our records show that you are the owner of a vehicle affected by this action.

**About this Service Action:** Volkswagen is providing updated transmission control module (TCM) software to enhance an in-vehicle alert should a problem arise within the auxiliary hydraulic pump. Additionally, if a specific fault is found after the software is updated, a repair will be made to the transmission.

**What will we do?** Your authorized Volkswagen dealer will update the transmission control module (TCM) software in your vehicle. This work will take about an hour to complete and will be performed for you free of charge.

Additionally, if a specific fault is found after the software is updated, a repair will be made to the transmission. If this additional work is necessary, it will take about a day and will be performed for you free of charge.

Please keep in mind that your dealer may need additional time for the preparation of this service action, as well as to accommodate their daily workshop schedule.

**What should you do?** Please contact your authorized Volkswagen dealer as soon as possible to schedule this service. To set up an appointment online, please visit [www.vw.com/find-a-dealer](http://www.vw.com/find-a-dealer).

This service action will be available for you **free of charge only until December 31, 2026**. If you wish to have this service performed after that date, your dealer's normal costs associated with this repair will apply.

**Lease vehicles and address changes** If you are the lessor and registered owner of the vehicle identified in this action, please forward this letter immediately via first-class mail to the lessee within ten (10) days of receipt. If you have changed your address or sold the vehicle, please fill out the enclosed prepaid Owner Reply card and mail it to us so we can update our records.

**Can we assist you further?** If your authorized Volkswagen dealer fails or is unable to complete this work free of charge within a reasonable time, or if you should have any questions about this communication, please reach out to us using your preferred method of communication at [www.vw.com/contact](http://www.vw.com/contact) or by calling us at 800-893-5298.

**Checking your vehicle for open Recalls and Service Campaigns** To check your vehicle's eligibility for repair under this or any other recall/service campaign, please visit [www.vw.com/owners/recalls](http://www.vw.com/owners/recalls) and enter your Vehicle Identification Number (VIN) into the Recall/Service Campaign Lookup tool.

We apologize for any inconvenience this matter may cause; however we are taking this action to help ensure your vehicle continues to meet and exceed your expectations.

Sincerely,

Volkswagen Customer Protection

## Customer Letter Example (Canada)

<MONTH YEAR>

<CUSTOMER NAME>

<CUSTOMER ADDRESS>

<CUSTOMER CITY STATE ZIPCODE>

**This notice applies to your vehicle:** <MODEL YEAR> <BRAND> <CARLINE>, <VIN>

**Subject: Service Action 34K1 - Transmission Control Module (TCM) Software**

Dear Volkswagen Owner,

As part of Volkswagen's ongoing commitment to customer satisfaction, we are informing you of our decision to conduct a service action on certain 2018 model year Volkswagen Golf R vehicles. Our records show that you are the owner of a vehicle affected by this action.

**About this Service Action:** Volkswagen is providing updated transmission control module (TCM) software to enhance an in-vehicle alert should a problem arise within the auxiliary hydraulic pump. Additionally, if a specific fault is found after the software is updated, a repair will be made to the transmission.

**What will we do?** Your authorized Volkswagen dealer will update the transmission control module (TCM) software in your vehicle. This work will take about an hour to complete and will be performed for you free of charge.

Additionally, if a specific fault is found after the software is updated, a repair will be made to the transmission. If this additional work is necessary, it will take about a day and will be performed for you free of charge.

Please keep in mind that your dealer may need additional time for the preparation of this service action, as well as to accommodate their daily workshop schedule.

**What should you do?** In order to limit any possible inconvenience, please contact your authorized Volkswagen dealer as soon as possible to schedule this service. Please keep in mind that your dealer may need additional time for the preparation of the repair, as well as to accommodate their daily workshop schedule.

This service action will be available for you **free of charge only until December 31, 2026**. If you wish to have this service performed after that date, your dealer's normal costs associated with this repair will apply.

**Lease vehicles and address changes** If you are the lessor and registered owner of the vehicle identified in this action, please forward this letter immediately via first-class mail to the lessee within ten (10) days of receipt. If you have changed your address or sold the vehicle, please fill out the enclosed prepaid Owner Reply card and mail it to us so we can update our records.

**Can we assist you further?** If your authorized Volkswagen dealer fails or is unable to complete this work free of charge within a reasonable time, please contact Customer Relations, Monday through Friday from 8AM to 8PM EST by phone at 1-800-822-8987 or via our "Contact Us" page at [www.vw.ca](http://www.vw.ca).

We apologize for any inconvenience this matter may cause; however we are taking this action to help ensure your vehicle continues to meet and exceed your expectations.

Sincerely,

Volkswagen Customer Protection

## Repair Overview

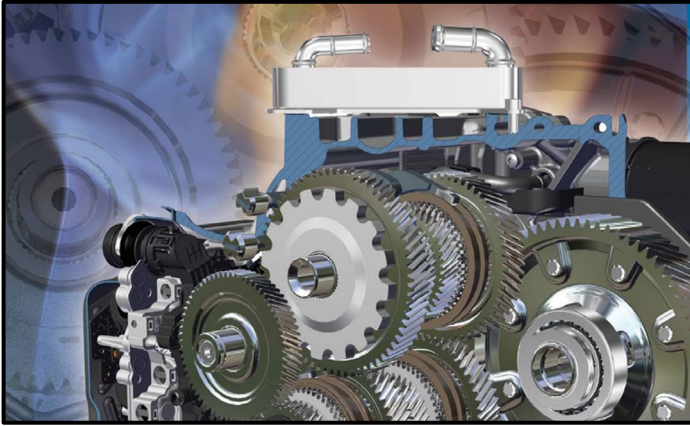



- Update TCM software.
- Perform road test and check for TCM faults afterward.
- Replace auxiliary hydraulic pump inside gearbox only if specific faults set.

### ! NOTE

- These repair instructions may differ from the labor operations and labor times listed in ELSA.
- Damages resulting from improper repair or failure to follow these work instructions are the dealer's responsibility and are not eligible for reimbursement under this action.
- This procedure must be read in its entirety prior to performing the repair.
- Due to variations in vehicle equipment and options, the steps/illustrations in this work procedure may not identically match all affected vehicles.
- Diagnosis and repair of pre-existing conditions in the vehicle are not covered under this action.
- When working during extreme temperatures, it is recommended that the vehicle be allowed to acclimate inside the shop to avoid temperature-related component damage/breakage.











## Required Tools (software update)





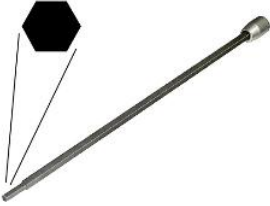





	<p>Battery Tester/Charger -VAS5908- (or equivalent charger with a current rating of at least 70A)</p>		<p>Diagnostic Tester -VAS6150X/VAS6160X- (or equivalent)</p>
---	---	--	--

## Required Tools (auxiliary hydraulic pump replacement – if required)

**NOTE: Refer to ELSA Repair Manual as needed for additional tools not listed here**

	<p>Transmission Support -3282- (or equivalent, -T40173- for example)</p>		<p>Transmission Support -VW353-</p>
	<p>Holding Plate -VW309A-</p>		<p>Engine and Transmission Holder -VAS6095A-</p>
	<p>Slide Hammer Set -VW771- (or equivalent)</p>		<p>Socket - 8mm -T40276- (or equivalent)</p>
	<p>Socket And Extended Bit -T10107A- (or equivalent)</p>		<p>T-Handle Hook -3438- (or equivalent) Qty. = 2</p>

 <p>Puller - Unit Injector -T10055-</p>	 <p>Drive Axle Wedge Tool -T10161-</p>
 <p>Retaining Bar -T10524-</p>	 <p>Puller - Bevel Gear -T10472-</p>
 <p>Puller -T10525-</p>	 <p>Hose Clamps - Up To 25mm -3094- (or equivalent)</p>
 <p>Engine Bung Set -VAS6122- (or equivalent)</p>	 <p>Engine and Gearbox Jack -VAS6931- (or equivalent)</p>
 <p>Pry lever -80-200- (or equivalent)</p>	 <p>Socket - Xzn 14 -T10061- (or equivalent)</p>
 <p>Thrust Piece -T10526-</p>	 <p>Seal Installer - Bevel Box -T10243- (or equivalent)</p>

 <p>Bearing Installer - Bearing Press Piece -VW207C-</p>	 <p>Counter Support (Kukko 22/1) - VAS251621- (or equivalent)</p>
 <p>Internal Puller -VAS251635- (or equivalent)</p>	 <p>Circlip Pliers -VAS5503A- (or equivalent)</p>
 <p>Guide Pins – Gearbox -T40288-</p>	 <p>Thrust Piece -T10457- (or equivalent)</p>
 <p>Insert Tool - 18mm -T10179- (or equivalent)</p>	 <p>Transmission Support - Mounting Plate 49 -3282/49- (or equivalent)</p>
 <p>Engine Support Set -10-222B- (or equivalent)</p>	 <p>Transmission Support - Pins 29 -3282/29- (or equivalent)</p>

## Repair Instruction

### Section A - Check for Previous Repair

Applicable criteria ID(s)	Campaign/Action Status
01 ← <b>2</b>	Open ← <b>1</b>

**EXAMPLE**

Campaign/Action	Start	Designation
← <b>3</b> →	2015-11-10	W-SERV_ACT -
	2018-12-13	RECALL -
	2017-05-16	A-RECALL -

**EXAMPLE**

- Enter the VIN in Elsa and proceed to the “Campaign/Action” screen.

#### TIP

On the date of repair, print this screen and keep a copy with the repair order.

- Confirm the Campaign/Action is open <arrow 1>. If the status is closed, no further work is required.
- Note the Applicable Criteria ID <arrow 2> for use in determining the correct work to be done and corresponding parts associated.

#### CRITICAL REPAIR STEP

 **STOP!** 

If multiple software update Campaign/Actions are open, they must be performed in order of the Start date <arrow 3>. The oldest should be performed first.

- **All Safety Recalls must be completed prior to completing this campaign.**
- **Proceed to Section B.**

#### NOTE

If the transmission was replaced on a previous service (after 10-01-2018), this work does not have to be performed. Contact Volkswagen Warranty if there was a previous transmission replacement.

## Section B – Update TCM Software

### NOTE

**Prior to launching the VAS Diagnostic Tester and starting an update, ensure the following conditions are met;**

- ✓ **The ODIS software is completely up to date.**
  - Refer to the “Alerts” section on ServiceNet home page for the current ODIS version.
- ✓ **The battery charger is connected to the vehicle battery and remains connected for the duration of the software update.**
  - Battery voltage must remain above 12.5 volts for the duration of the software update. Failure to do so may cause the update to fail, which could result in damage to the control module. Control modules damaged by insufficient voltage will not be covered.
- ✓ **The screen saver and power saving settings are off.**
  - Failure to do so may result in the tester entering power save mode during the software update, which could result in damage to the control module.
- ✓ **The VAS Diagnostic Tester is plugged in using the supplied power adapters.**
  - Under no circumstances should the tester be used on battery power alone during the software update. Failure to do so may result in the tester powering off during the update, which could result in damage to the control module.
- ✓ **The VAS Diagnostics Interface MUST ONLY be connected to the tester with a USB cable.**
  - Performing a software update using a Bluetooth or WiFi connection increases the risk of losing connection during the update, which could result in damage to the control module. It also greatly increases the time required to perform the update. Requests for additional time or parts will be denied if the GFF log shows the update was performed using Bluetooth or WiFi.

### WARNING

Radiator Fan(s) may cycle ON high speed during the Update Process! There is a serious risk that personal injury may result if contact is made with spinning fan blades. Keep hands and all objects away from Radiator Fan(s) during Update Process!

### TIP

To Update-Programming using SVM, review and follow instructions in Technical Bulletin 2014603: *Software Version Management (SVM) Operating Instructions*.

The SVM Process must be completed in its entirety so the database receives the update confirmation response. A warranty claim may not be reimbursed if there is no confirmation response to support the claim.

 **NOTE**

- Damages resulting from improper repair or failure to follow these work instructions are the dealer's responsibility and are not eligible for reimbursement under this action.
- Diagnosis and repair of pre-existing conditions in the vehicle are not covered under this action.

 **NOTE**

- All campaign software updates must be completed during a single, standalone ODIS Diagnostic Session. You must fully complete this campaign and send all logs before beginning any other campaigns or operations.
- If there are any ODIS "Hot-Fix" patches installed, they must be removed from the scan tool before beginning this operation. ODIS "Hot-Fix" patches may affect the update process.

- Open the hood.
- Open the battery cover.
- Switch the ignition on.
- Apply the parking brake.
- Switch off all consumers (headlights, heated seats, climate control, etc.).
- Connect the VAS6150X/VAS6160X Diagnostic Tester to the vehicle.
- Start the ODIS program.
- Attach the battery charger to the vehicle battery.

 **NOTE**

**Vehicles with Battery Monitoring Control Module -J367- and/or an EFB Battery:**

When connecting the charger to the battery, connect the positive cable to the positive terminal of the battery and connect the negative cable to the grounding lug on the chassis. **DO NOT** connect the ground cable directly to negative terminal of the battery.

- Turn the hazards on.

 **CAUTION**

The procedure may cancel itself if the hazard warning lights are not switched on. The hazard warning lights prevent the system from switching to bus sleep mode during the update.





- Confirm that scan tool is communicating with the diagnostic head by USB <Green Arrow>.
  - If the Bluetooth symbol is shown <Red Arrow> then disconnect the diagnostic head from the vehicle and reconnect the USB cable to the diagnostic head and then reattach to the vehicle.
- Upon ODIS startup, verify the “Diagnosis” operating mode is selected <as shown>.

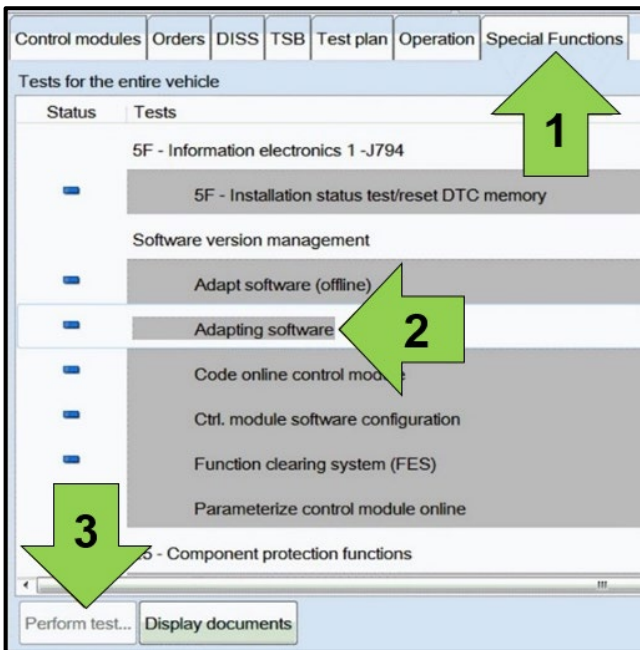

- Once the GFF scan is complete, select “Special functions” <arrow 1>, then “Adapting software” <arrow 2>, then select “Perform test” <arrow 3>.

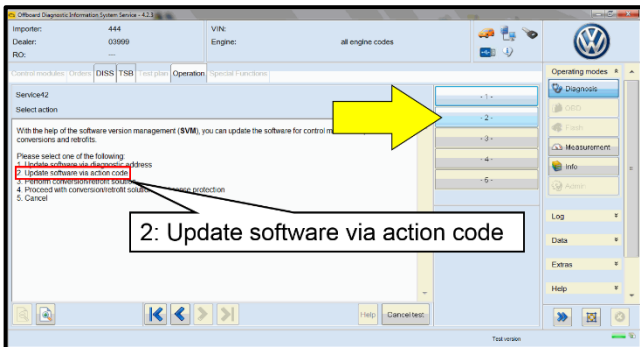

- Select the correct option to “Update software via action code” OR “Software update via measured code”.

**NOTE**  
The different options to perform the SVM operation may vary based on model.

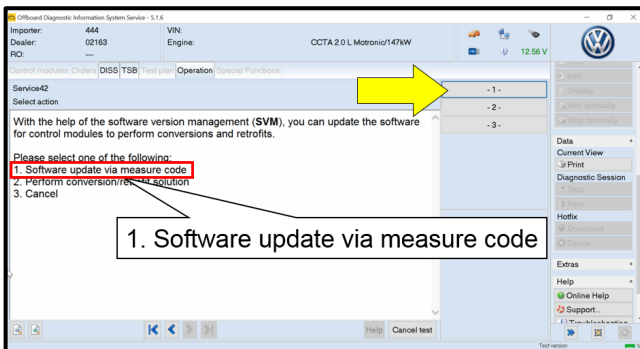

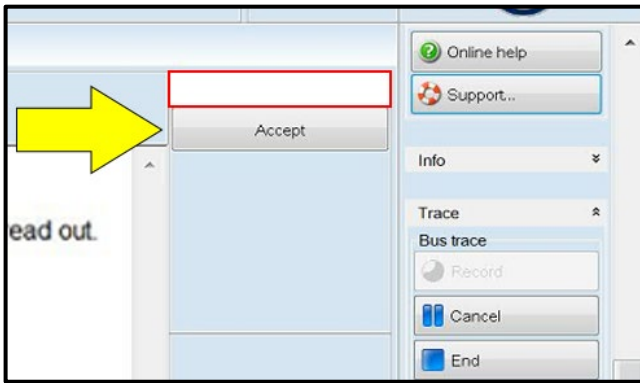

**NOTE**

**Using Bluetooth for this action is PROHIBITED!**

Damage caused to electronic components (e.g. ECM, TCM, etc.) during the SVM flash process is not covered.

- Enter the corrective action code (SVM code) as listed below.

<b>SVM code</b>
<b>4028</b>

- Select "Accept" <arrow> and follow the on screen prompts.

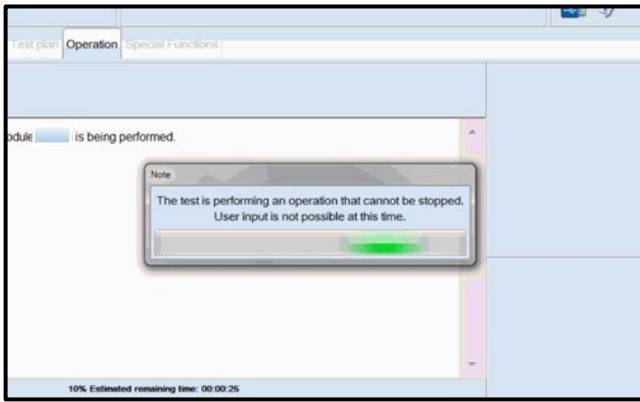

- During the flash, this screen appears when each operation is performed:

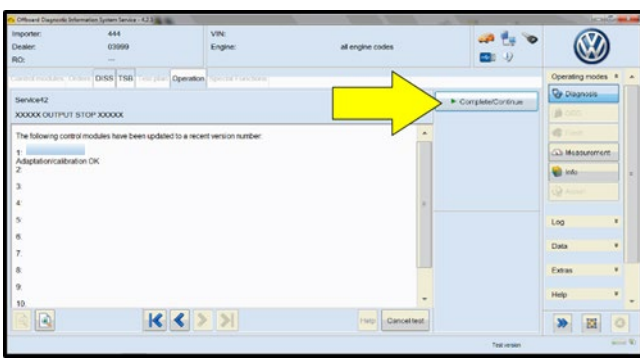

- Select Complete/Continue <arrow> after each operation is completed.

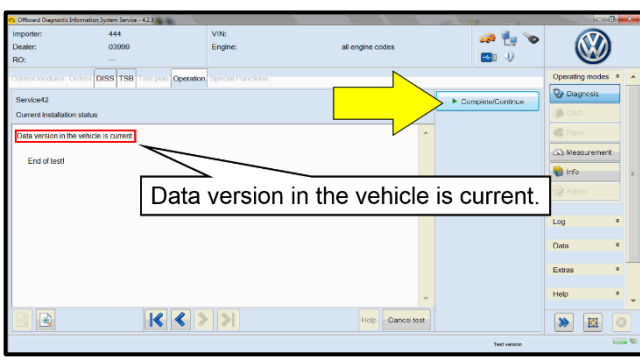

- When the SVM update is complete a confirmation message is displayed <as shown>.
- Select "Complete/Continue" <arrow>.

**TIP**

If the software in the vehicle is already current, a message may appear indicating this. If this occurs, complete the ODIS test plan and send the diagnostic protocol online.



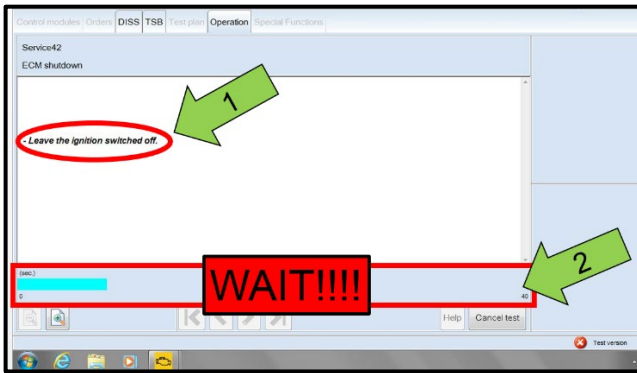

**NOTE**

- It is **IMPERATIVE** that **ALL** of the ignition cycle on/off delay requests are fulfilled in their entirety during this flash process <arrow 1>.
- Failing to wait for the ignition on/off timing cycle to complete (progress bar and countdown timer <arrow 2>) before cycling the ignition on/off **MAY** damage a control module.
- Damage to control modules as a result of failing to wait the specified time displayed by the progress bar and countdown timer <arrow 2> are **NOT** covered under this action.

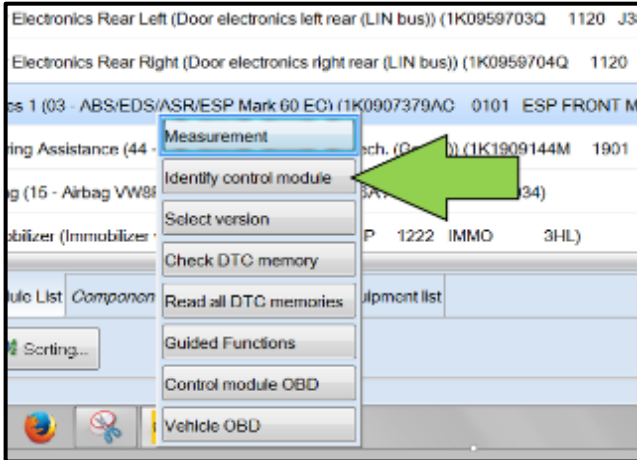

- After the software update is completed and before sending the GFF Log Online:
  - Select the “Control Module” tab.
  - Scroll down and right click on the module that was updated (0002).
  - Select “Identify Control Module” <arrow>.

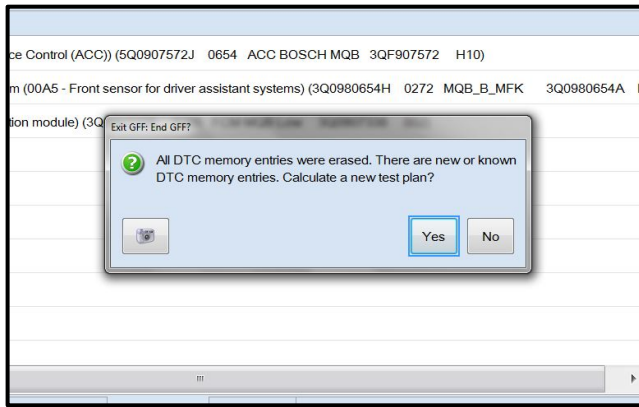

- Exit GFF and send diagnostic protocol online when prompted.

#### ! NOTE

Static communication faults may store in various control modules during the flash. These faults can only be cleared by following one of these steps:

- Drive the vehicle a short distance (around the parking lot, for example).
  - After selecting “Yes”, turn the ignition off for 30 seconds, turn it back on and repeat the GFF exit program.
  - Clear faults using OBD (an additional key cycle may also be required).
- Release the parking brake.
  - Disconnect the VAS tester.
  - Switch off and disconnect the battery charger.
  - Reinstall the battery cover.

#### After the update:

- Perform a short road test (2-5 minutes).
- If NO gearbox warning lamp or gearbox warning message appears in the instrument cluster:
  - No further work is required.
  - Proceed to Section D.
- If the gearbox warning lamp or a gearbox warning message appears in the instrument cluster:
  - The fault memory must be read out.
  - If fault “POC2900 – Activation for auxiliary hydraulic pump for transmission oil implausible” is set:
    - The auxiliary hydraulic pump must be replaced.
    - Proceed to Section C.

#### ! NOTE

If the gearbox warning lamp lights up at a later date (after the vehicle has been returned to the customer), please refer to Technical Bulletin 2070973 (US) for claiming instructions.

## Section C – Replacing Auxiliary Hydraulic Pump

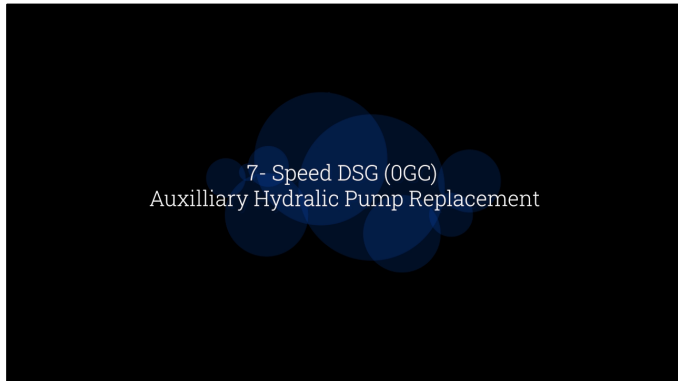

A video outlining replacement of the auxiliary hydraulic pump is available.

Click on the link below or scan the QR code to access the video.

<https://vwcup.track360.com/library/13062>



### NOTE

If internal or external damage caused by the auxiliary hydraulic pump bolts coming loose is found before or during the repair:

- Take clear photos
- U.S. dealers: Create a WISE Campaign Authorization request and attach photos for review.
- Canadian dealers: Create a TAC WEB ticket with the photos attached for review.

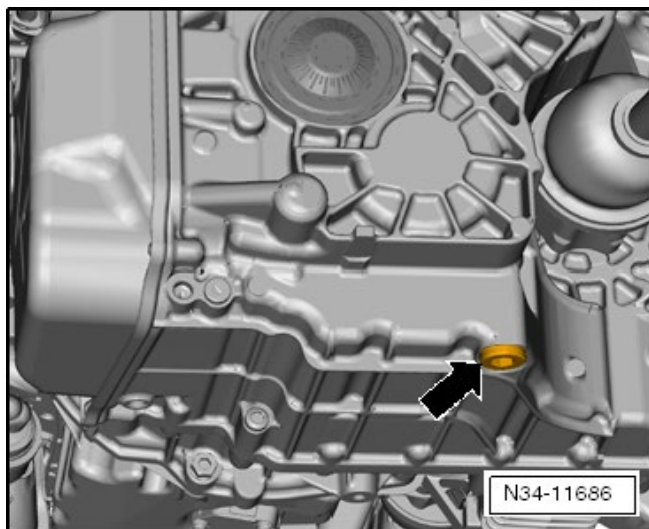

### Drain gear oil:

- See ELSA Repair Manual: *Repair manual > Drivetrain > 7-Speed DSG Transmission 0GC > 34 Controls, Housing > Transmission Fluid > Transmission Fluid, Draining and Filling*

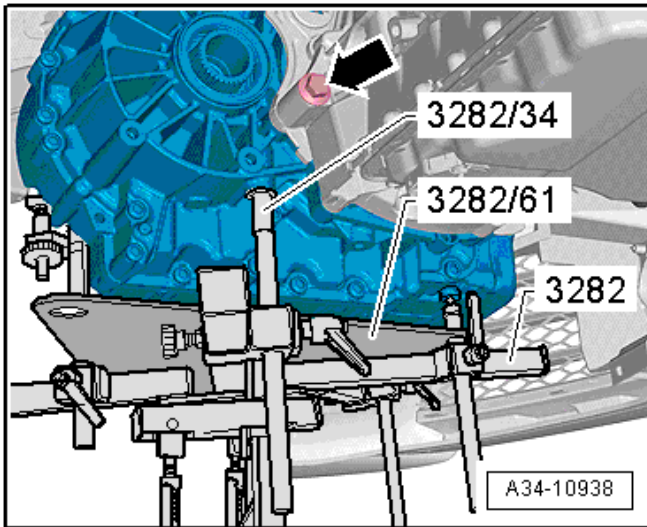

**Remove transmission:**

- See ELSA Repair Manual: *Repair manual > Drivetrain > 7-Speed DSG Transmission 0GC > 34 Controls, Housing > Transmission, Removing and Installing > Transmission, Removing, Vehicles with Gasoline Engine*

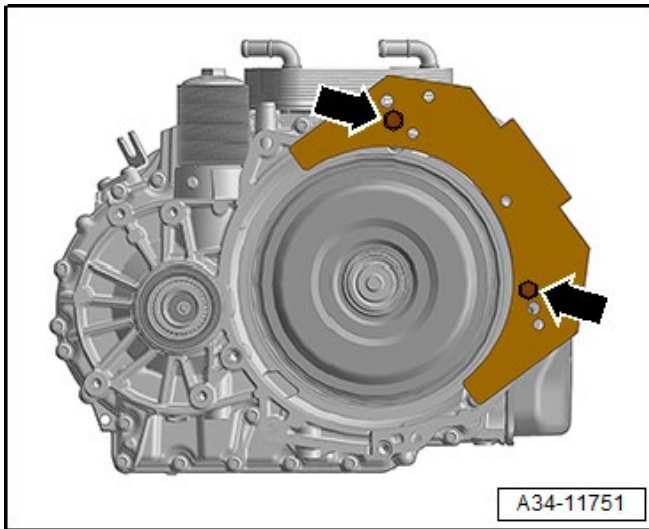

**Secure transmission to stand:**

- See ELSA Repair Manual: *Repair manual > Drivetrain > 7-Speed DSG Transmission 0GC > 34 Controls, Housing > Securing on Engine and Transmission Holder*

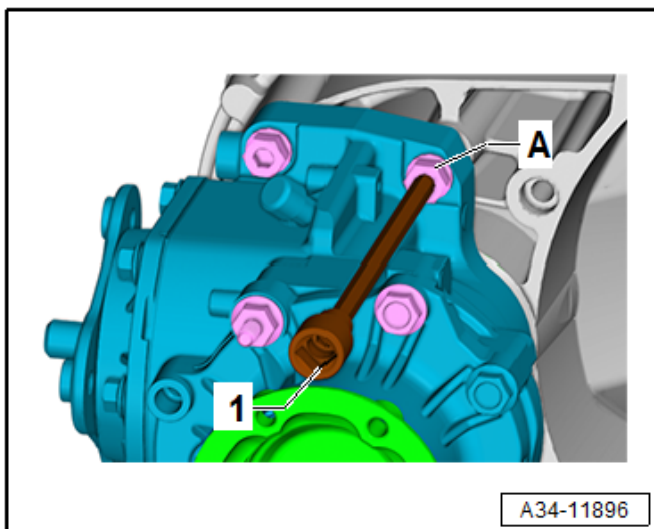

**Remove bevel box:**

- See ELSA Repair Manual: *Repair manual > Drivetrain > 7-Speed DSG Transmission 0GC > 34 Controls, Housing > Bevel Box > Bevel Box, Removing*

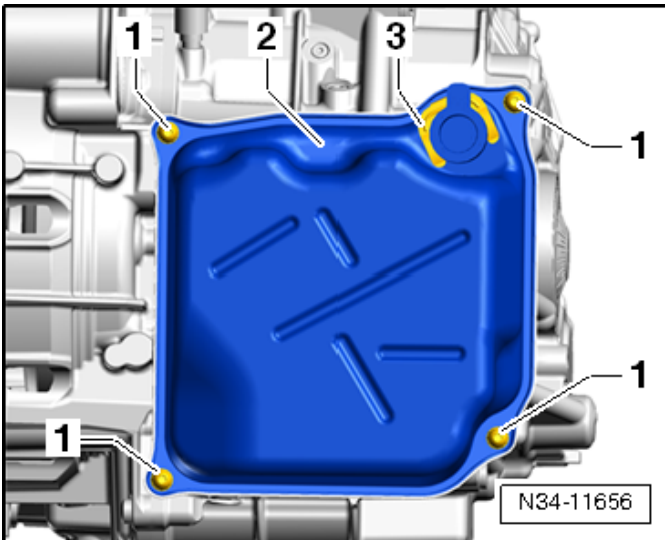

#### Remove transmission oil pan:

- Place used oil collection container under the transmission.
- Remove the clamp <3>.
- Loosen and remove the screws <1> in a diagonal sequence.
- Remove the oil pan <2> and if necessary loosen the oil pan by hitting lightly with a rubber hammer.

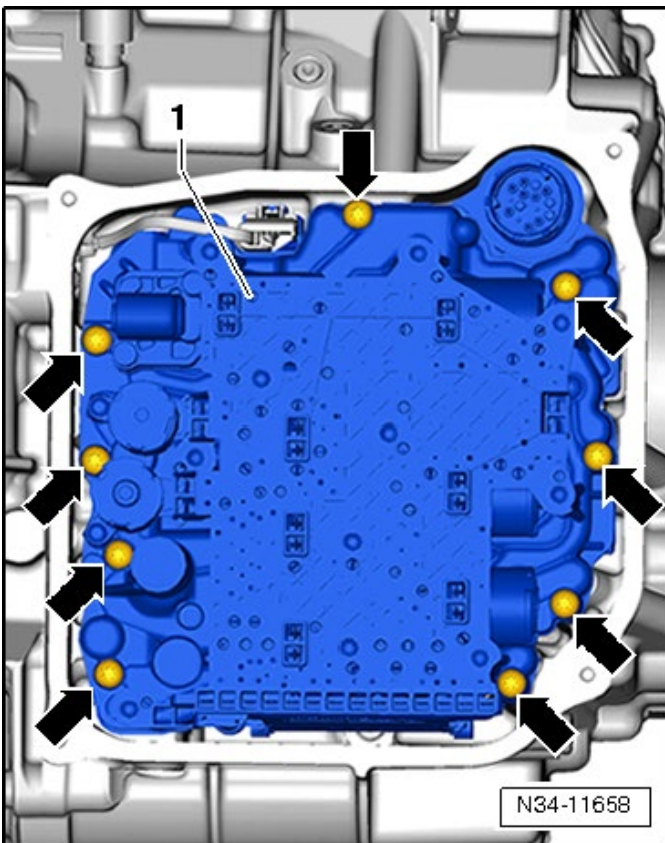

#### Remove mechatronic:

- Loosen and remove the screws <arrows> in a diagonal sequence.
- Carefully remove the mechatronic <1>.



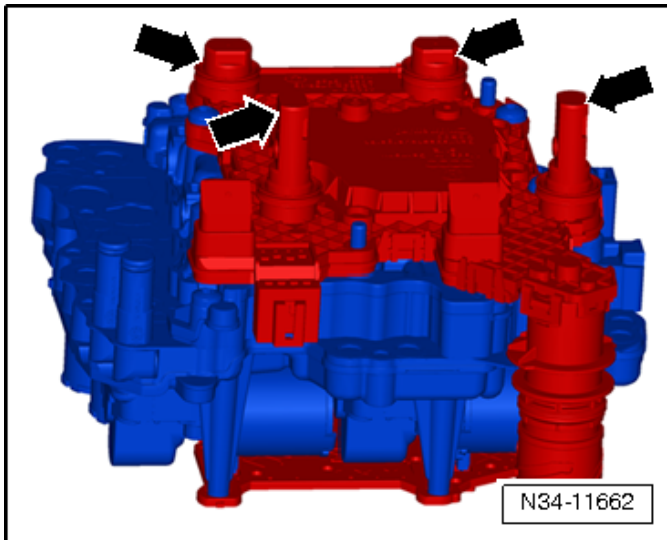

**Store the Mechatronic properly:**

- Store the Mechatronic so that the sensors <arrows> face upward.
- Place and cover the mechatronic on clean, lint free cloths.

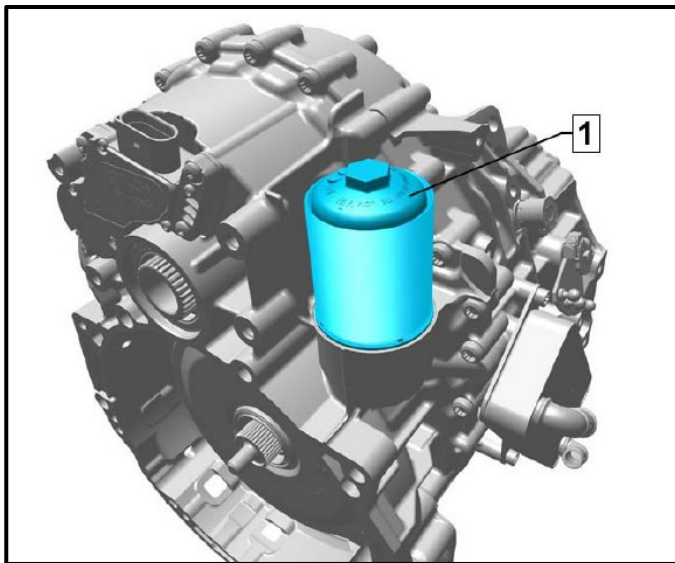

**Remove gear oil filter:**

- Remove gear oil filter housing <1> and filter.

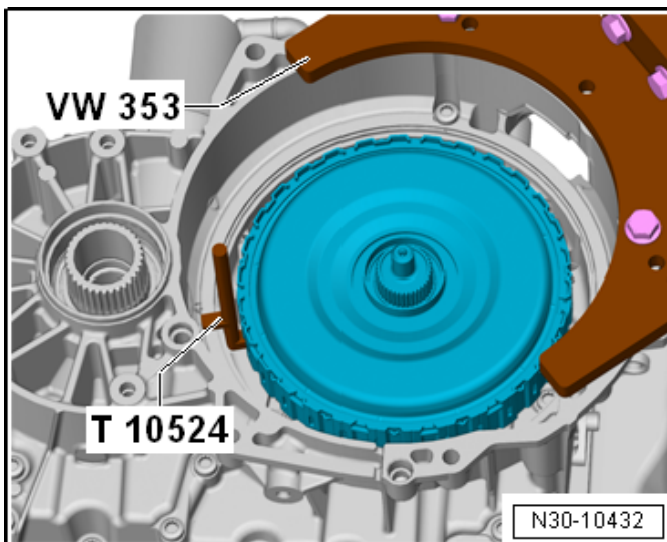

**Remove dual clutch:**

- See ELSA Repair Manual: *Repair manual > Drivetrain > 7-Speed Dual Clutch Transmission 0GC > 30 Clutch > Clutch > Dual Clutch, Removing*

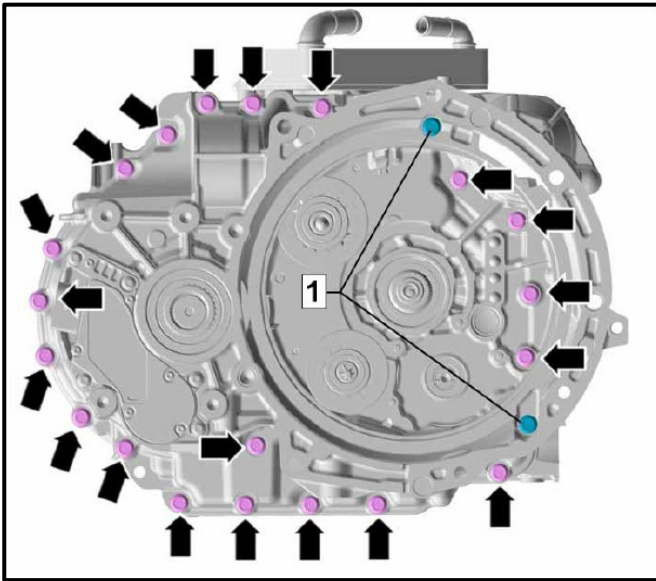

**Remove housing bolts on clutch side:**

- **DO NOT REMOVE BOLTS <1>.**
- Remove bolts <arrows>.
- Note the lengths of the removed bolts. There are two different length bolts.

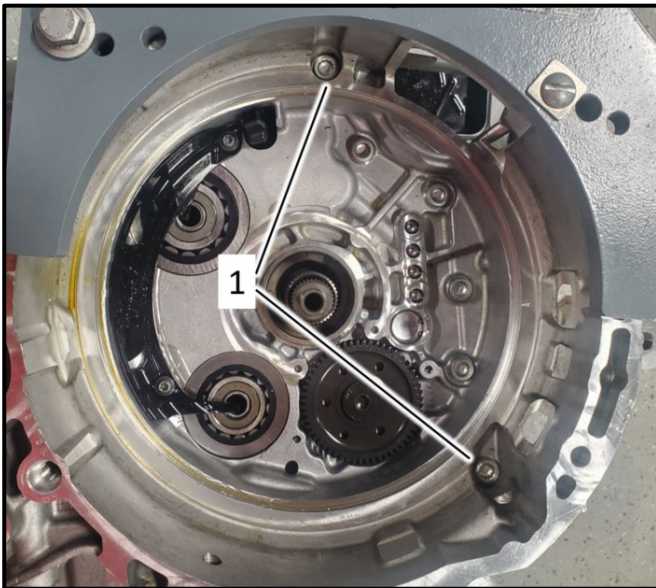

- Alternate view of the two bolts <1> that are not removed at this time.

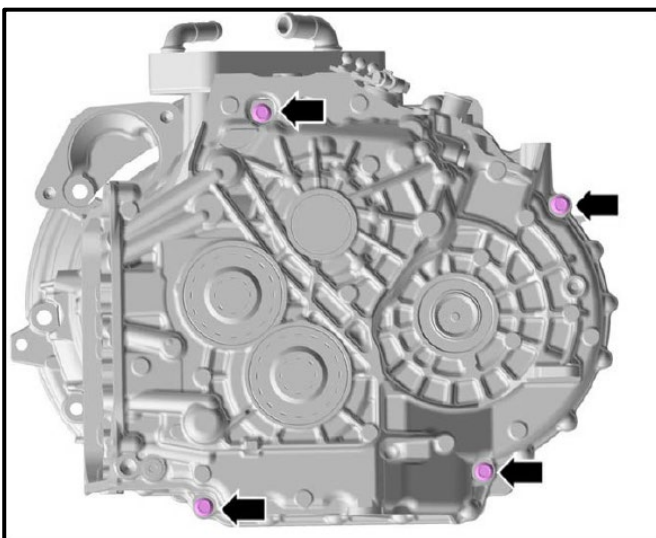

**Remove housing bolts on gearbox side:**

- Rotate transmission on stand.
- Remove bolts <arrows>.

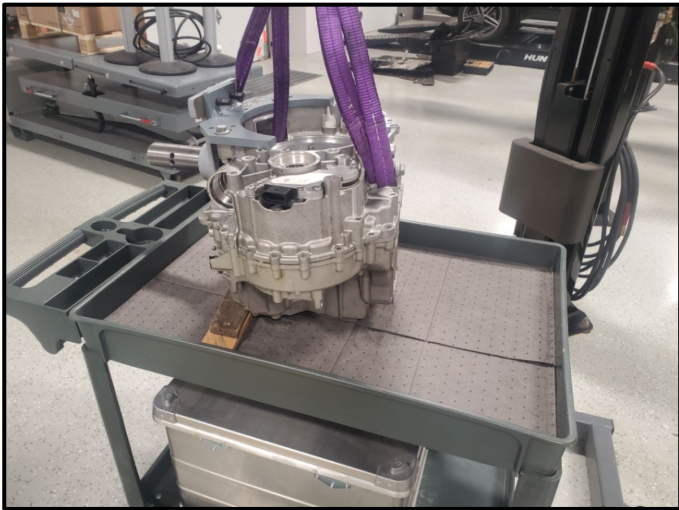

### Move transmission:

- Move transmission to a suitable work bench or cart.
- The splined shaft must face upward.
- Support the transmission from tipping using wood blocks as needed.

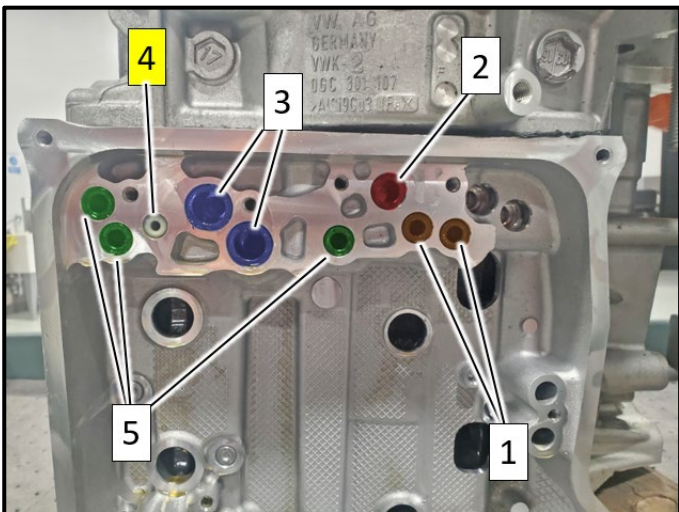

### Remove oil guide tubes:

- Loosen each oil tube by turning slightly using suitable circlip pliers.
- Then pull each oil tube out.
- Screw a suitable self-tapping screw or wood screw into the oil tube <4>, loosen the tube and then pull it out.

#### **!** NOTE

When removing the oil tubes, parts of the seals can become cut off.  
Make sure there no seal pieces left in the gearbox.

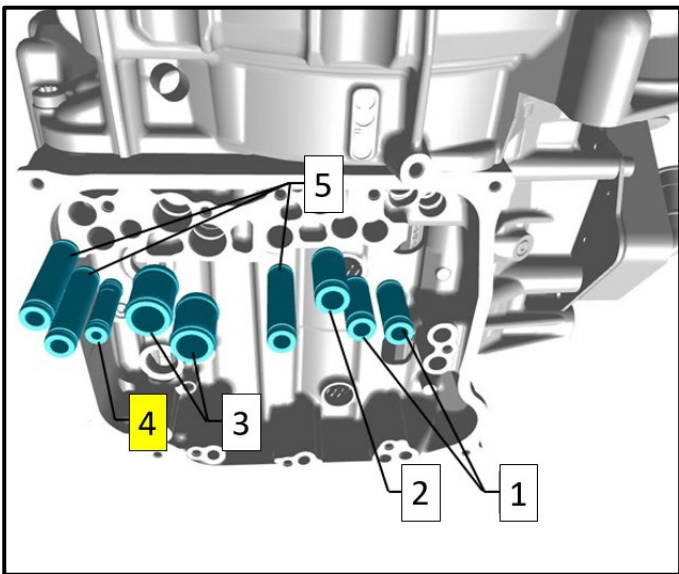



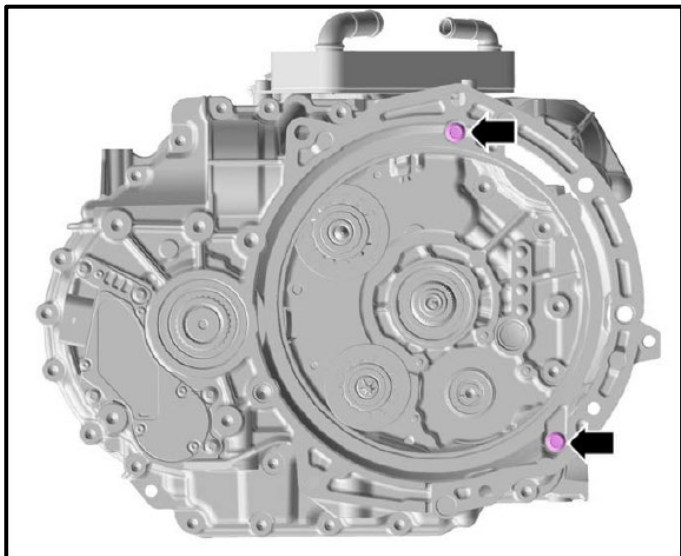

### Remove remaining two housing bolts:

- Remove bolts <arrows>.

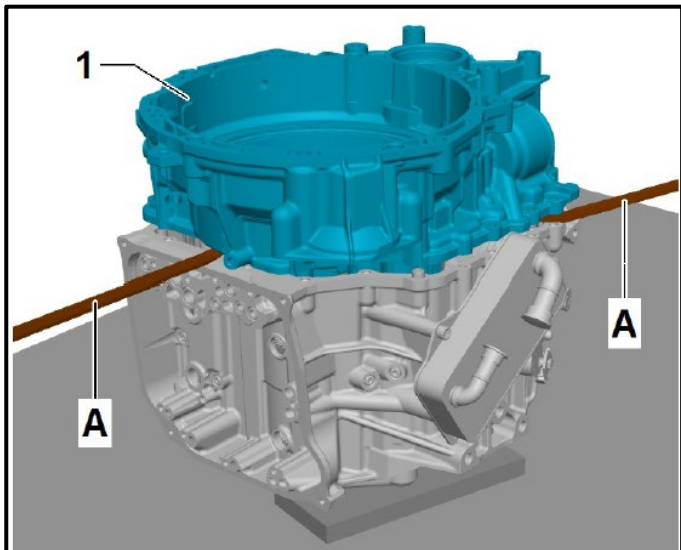

### Release sealant bead:

- Carefully release sealant bead between housing sections by applying minimal force using pry bars <A>.

#### ⚠ TIP

If the housings are not separating, make sure all of the oil guide tubes are removed.

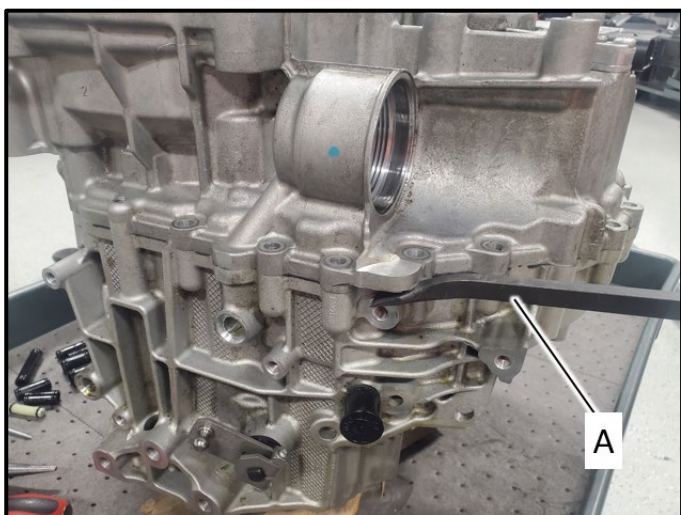

#### ⚠ NOTE

Proper positioning of pry bar <A> shown.

#### ⚠ CAUTION

#### **Risk of irreparable damage to gearbox housing.**

Use extreme care when releasing the sealant bead and do not use excessive force.

Pay close attention to surfaces being pried against so that damage does not occur.

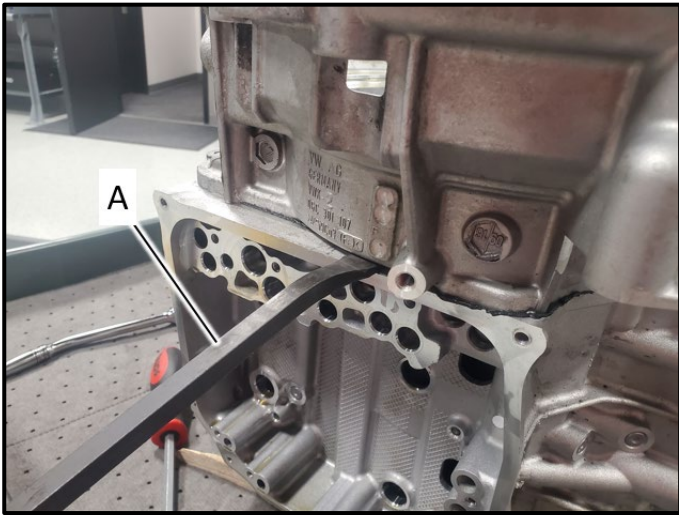

**NOTE**

Proper positioning of pry bar <A> shown.

**CAUTION**

**Risk of irreparable damage to gearbox housing.**  
 Use extreme care when releasing the sealant bead and do not use excessive force.  
 Pay close attention to surfaces being pried against so that damage does not occur.  
 Pay particular attention to the transmission oil pan sealing surface. The surface must not be compromised.

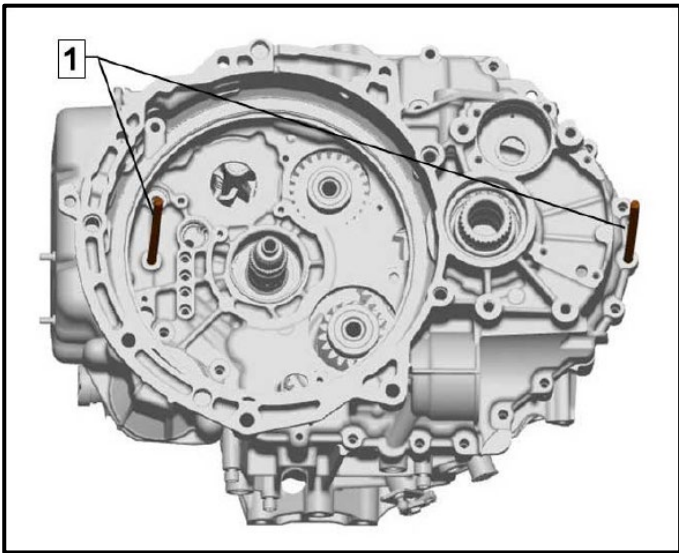

**Install guide pins:**

- Screw guide pins -T40288- <1> into gearbox housing on opposite sides, as shown.



- To aid in re-assembly, mark the position of both guide pins on gearbox housing with a felt-tip pen.

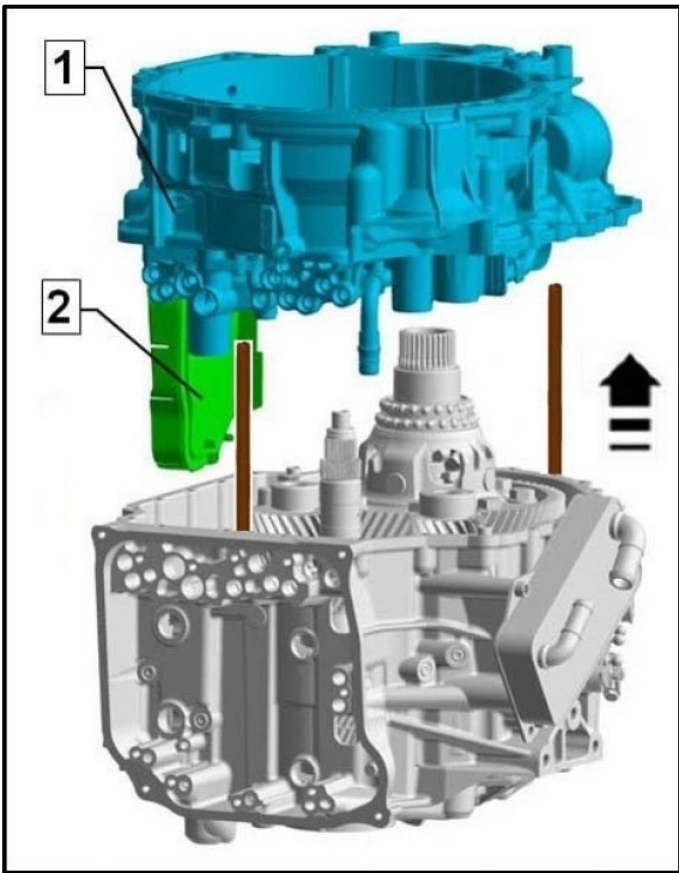

**Remove clutch housing:**

- Lift clutch housing <1> off vertically along guide pins.
- Place clutch housing <1> down safely on a suitable workbench with intake filter <2> facing upwards.

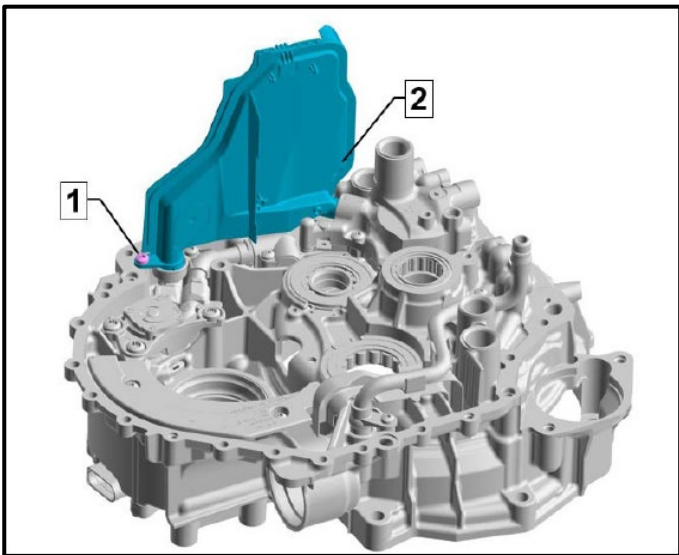

**Remove filter:**

- Remove bolt <1> and remove intake filter <2>.



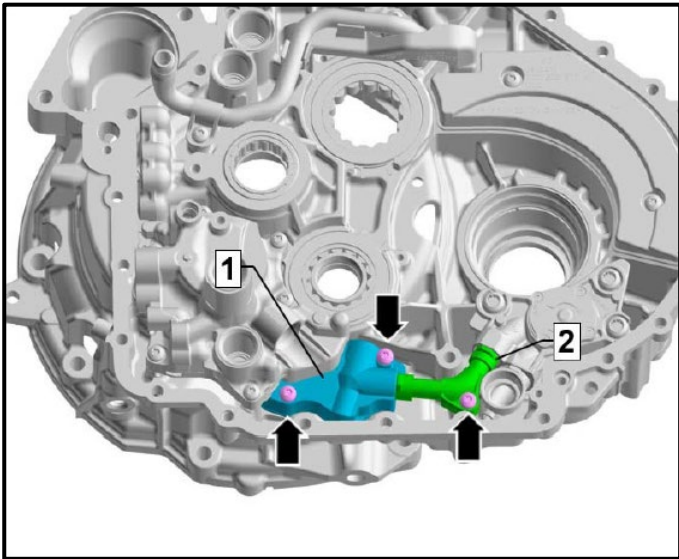

### Remove changeover valve bolts:

- The changeover valve and pipe are not removed.
- Remove bolts <arrows> for changeover valve <1> and oil pipe <2>.
- Note the length of the removed bolts. There are two different length bolts.

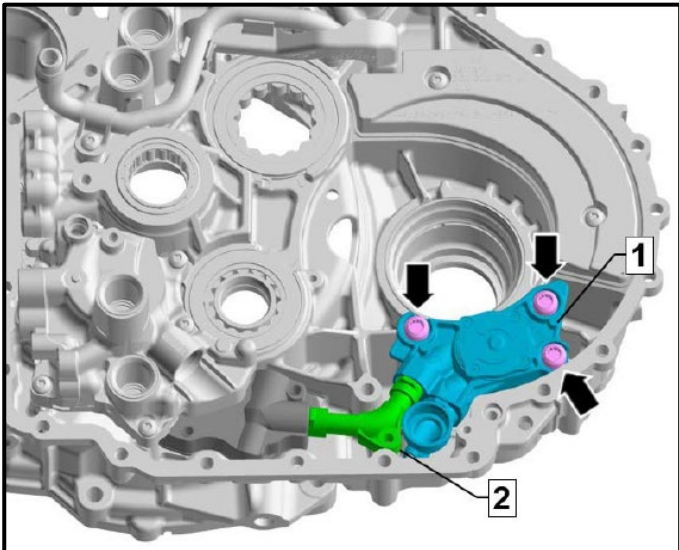

### Remove auxiliary hydraulic pump:

- Remove bolts <arrows>.
- Carefully detach auxiliary hydraulic pump <1> upwards and pull it out of oil pipe <2>.

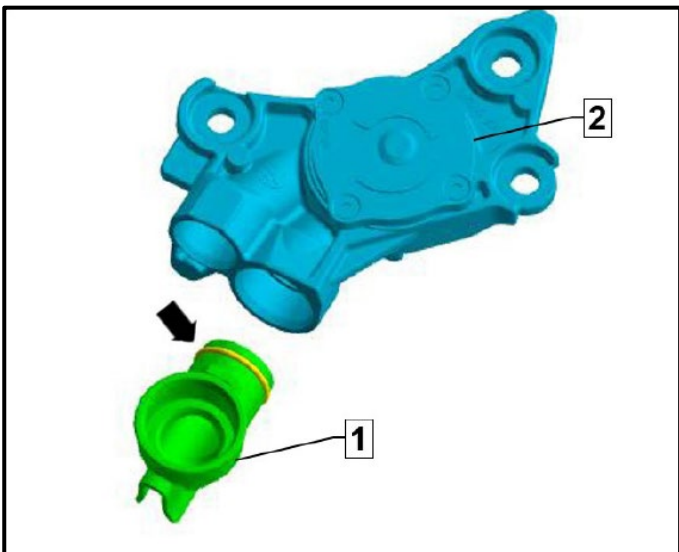

### Replacing auxiliary hydraulic pump:

- Fit a new oil pipe <1> from the repair kit to the new auxiliary hydraulic pump <2>.
- Coat the o-ring on the oil pipe with clean oil.

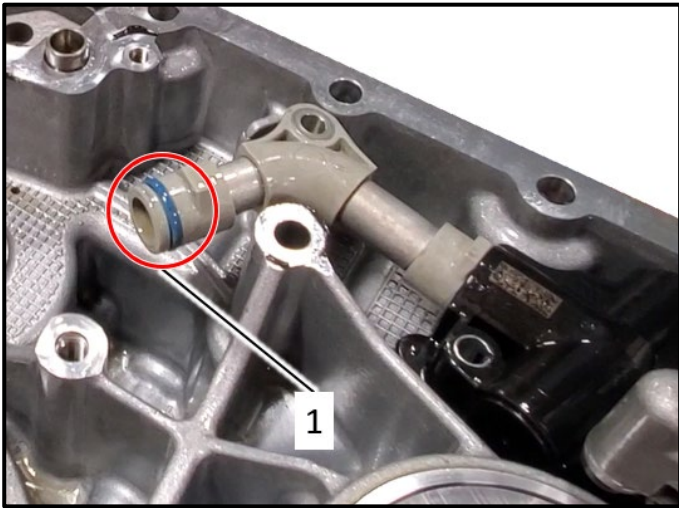

- Install new O-ring <1> from the repair kit on the changeover valve oil pipe.

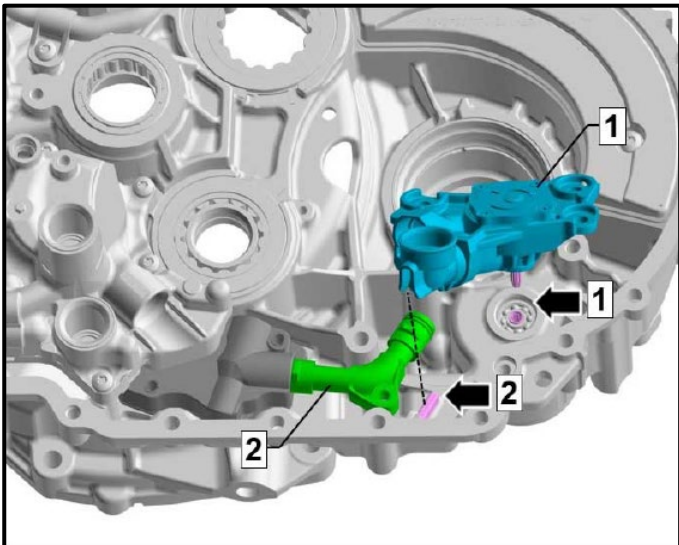

#### Install auxiliary hydraulic pump:

- Install new auxiliary hydraulic pump with oil pipe from the repair kit in the reverse order of removal.
- When installing, ensure that the shaft matches up with the splines in the housing <arrow 1> and the oil pipe guide is fitted on the rib <arrow 2> on the housing.

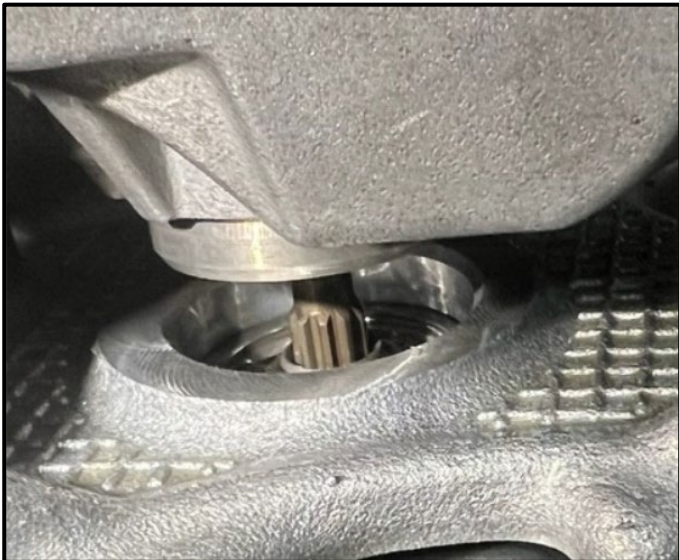

#### ! NOTE

Detail of auxiliary hydraulic pump shaft splines shown.

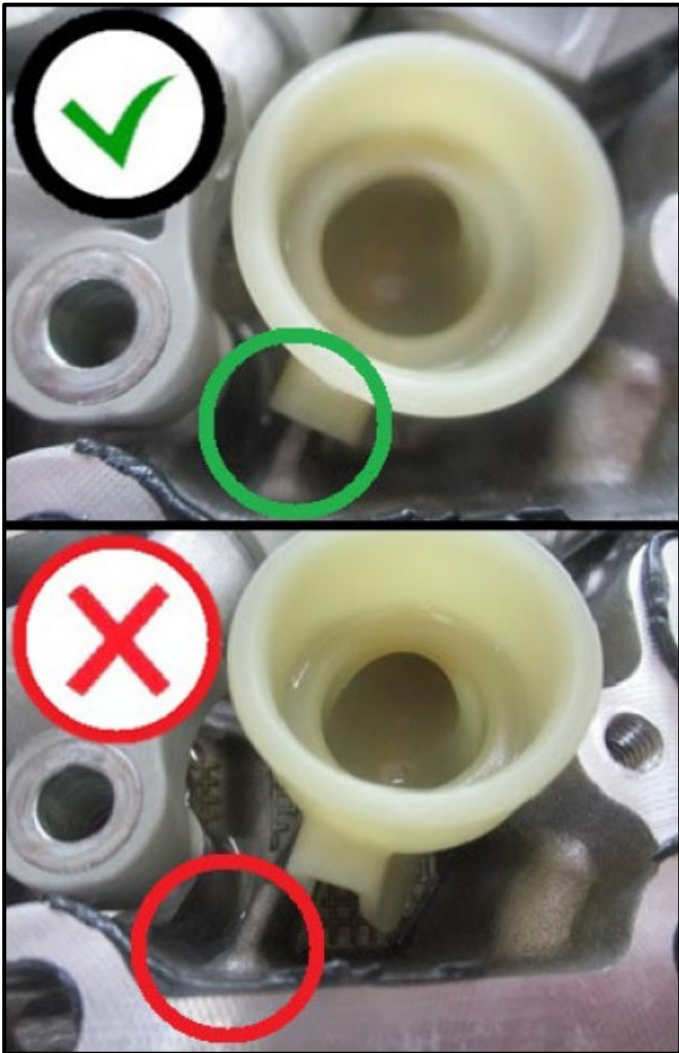

### Verify oil pipe installation:

- Verify that the oil pipe is installed correctly as shown.
- The recess on the oil pipe must fit correctly over the rib on the housing.

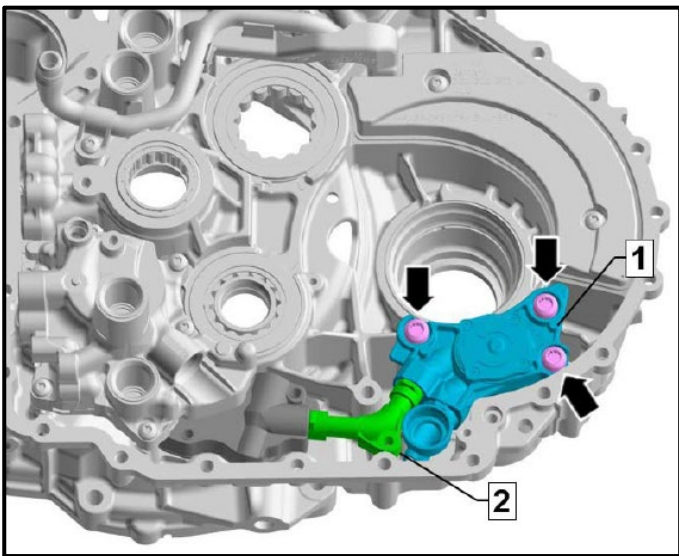

### Install new auxiliary hydraulic pump bolts:

- Install new bolts <arrows> from the repair kit and torque to 20 Nm + 90°.



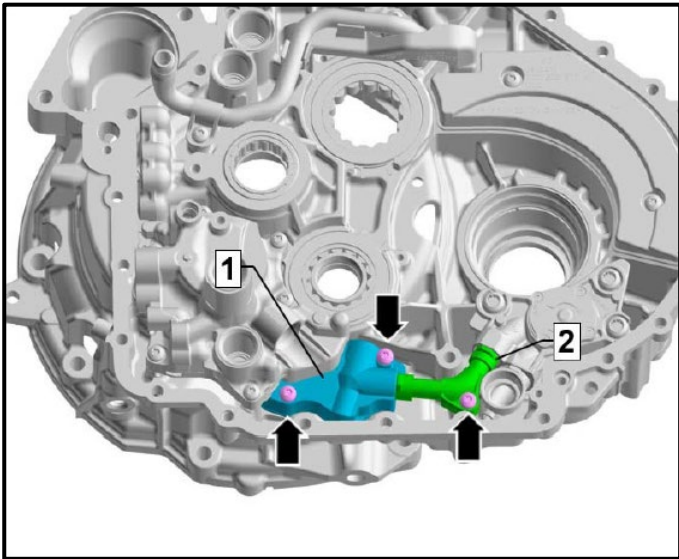

#### Install new bolts for changeover valve and oil pipe:

- Install new bolts <arrows> from the repair kit and torque to 8 Nm + 90°.



#### NOTE

Please note that the bolt for the oil pipe is shorter than the two bolts for the changeover valve.

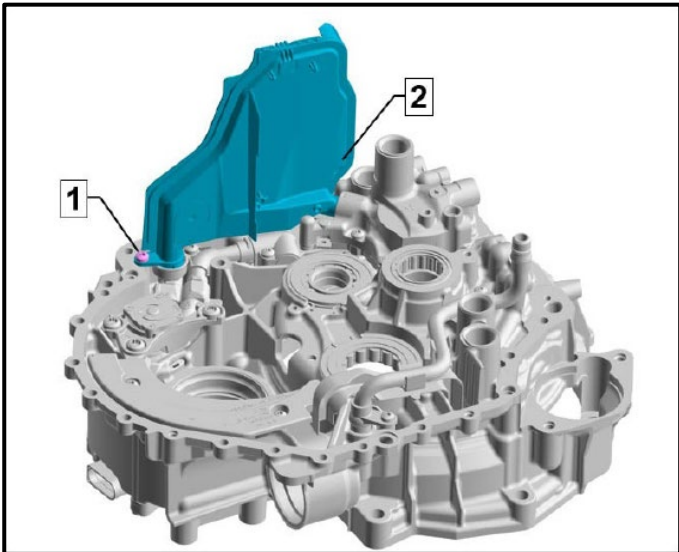

#### Install new filter and bolt:

- Install new filter <2> from the repair kit and torque new bolt from the repair kit <1> to 8 Nm + 90°.

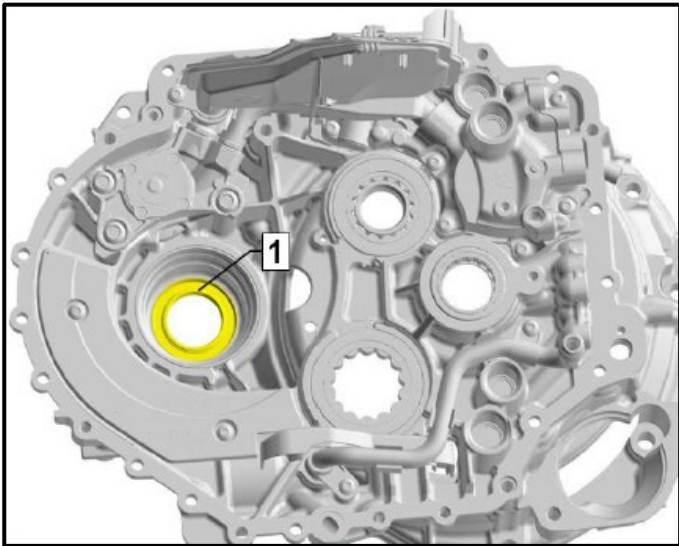

#### Remove oil seal:

- Remove oil seal <1> from clutch housing.

#### Prepare gearbox housing for assembly:

- Clean the sealing surfaces on both housings thoroughly.
- Allow cleaner to dry completely.
- Ensure there is no dirt or sealant residue left inside the gearbox.
- Ensure all oil passages are free of dirt and residue.
- Carefully press pistons for selector rods <arrows> into end position using a suitable tool (socket, for example) if necessary.

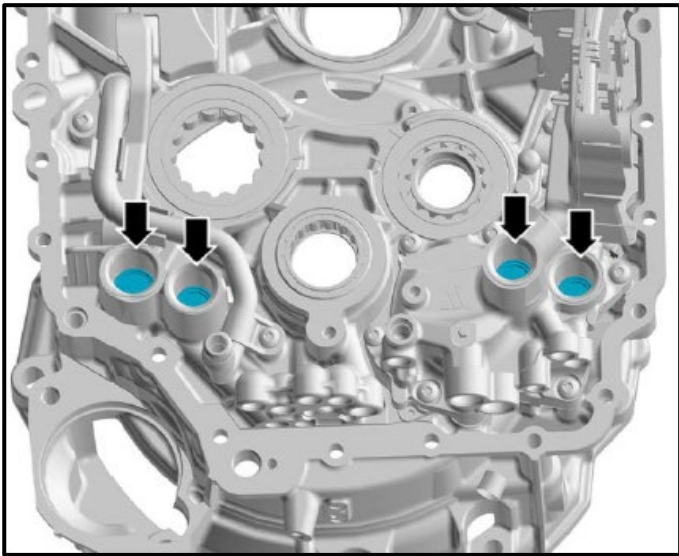



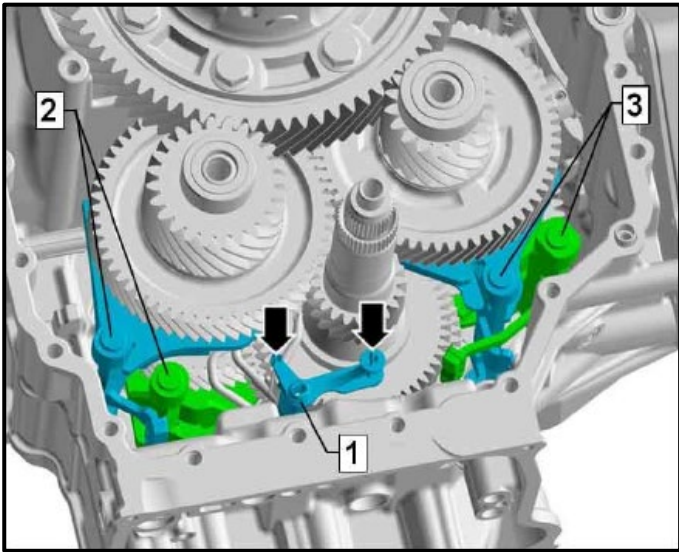

- Move shift forks <2> and <3> into neutral position.

**NOTE**

The shift forks are in the neutral position when the radius cut out on the shift forks are clearly visible in the center of the windows of the gearbox housing.

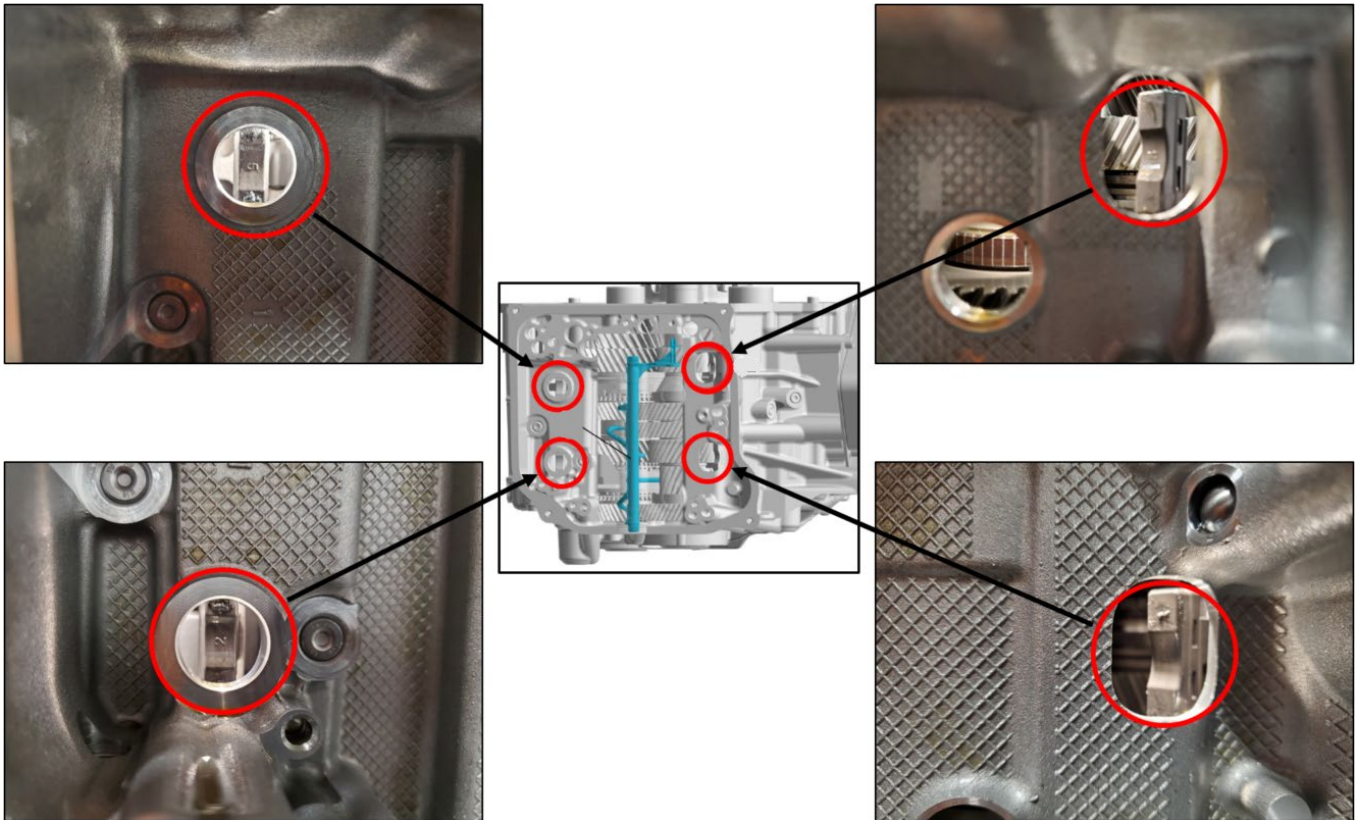

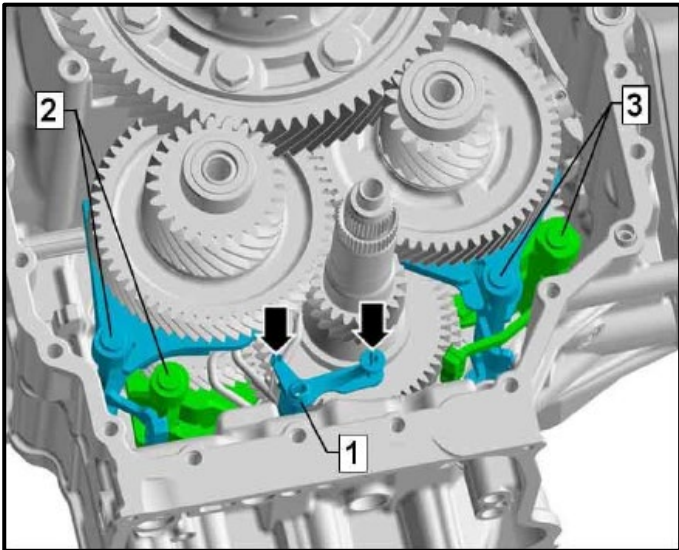

- Align injection pipe <1> correctly in housing; guides <arrows> must align precisely with clutch housing when fitted.
- Move selector forks <2> and <3> into neutral position.

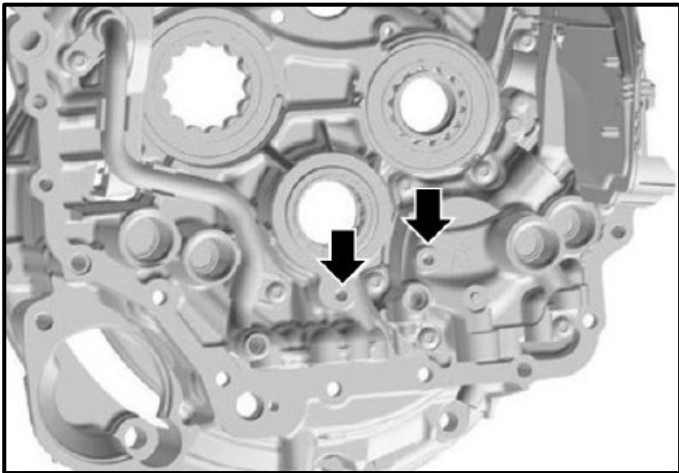

- The two guides of the injection pipe must be inserted precisely into the corresponding holes <arrows> in the clutch housing during assembly.
- In the event of an incorrect alignment, it will not be possible to install the clutch housing.

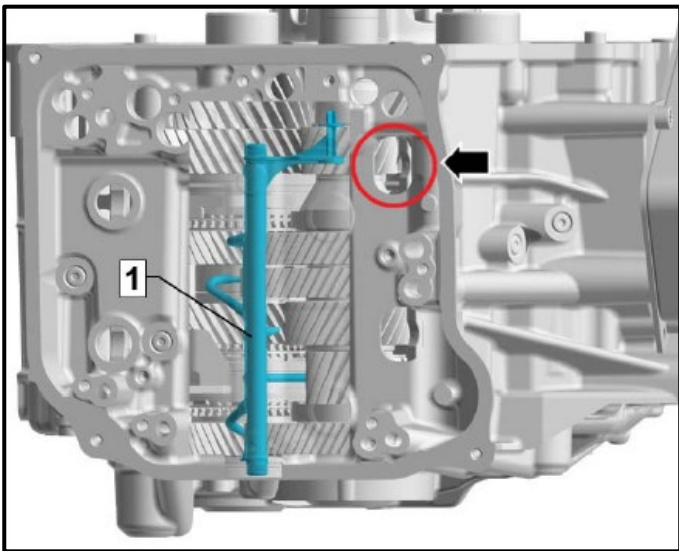

- When fitting the housing sections together, you can reach through the opening <arrow> with your finger to adjust the position of the injector pipe <1> slightly.

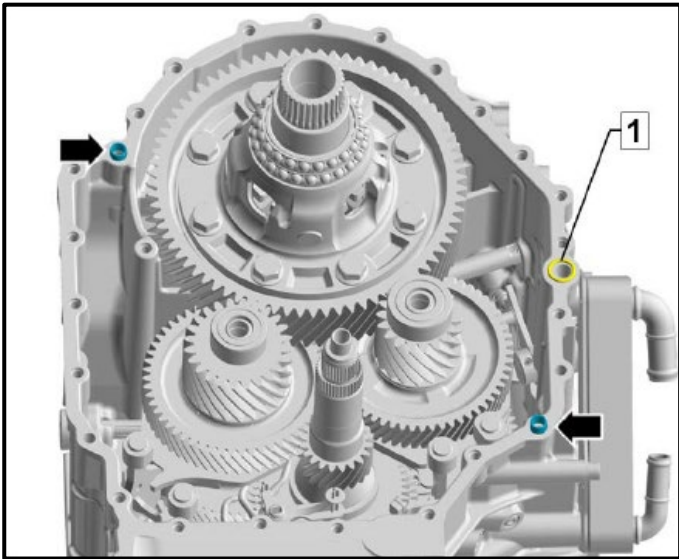

- Install new O-ring <1> from the repair kit.

**NOTE**

To aid in assembly, the O-ring can be held in place using no more than 1 gram of Vaseline.

- Check that dowel sleeves <arrows> are not damaged and are seated correctly.

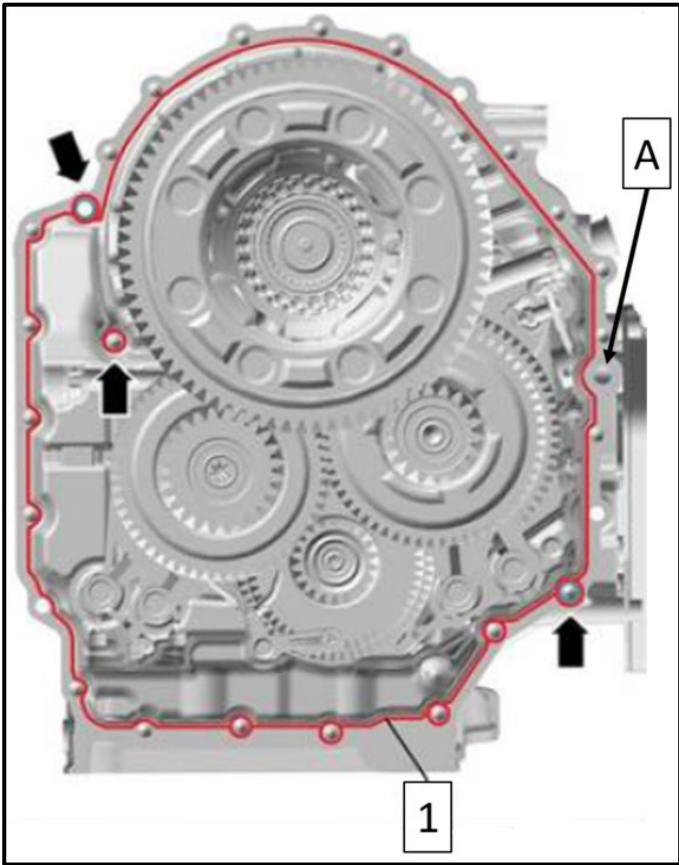

**Apply sealant:**

- Apply a bead of sealant <1> to the gearbox housing as shown.
- Ensure sealant is applied completely around any openings as shown in the illustration.
- Pay close attention to the dowel sleeves and “turret” <arrows>. Ensure sealant is applied completely around those openings.

**NOTE**

The O-ring is installed at area <A>. Note that sealant is only applied on the inside edge of the housing in the area of the O-ring. Do not allow sealant to enter the oil opening.



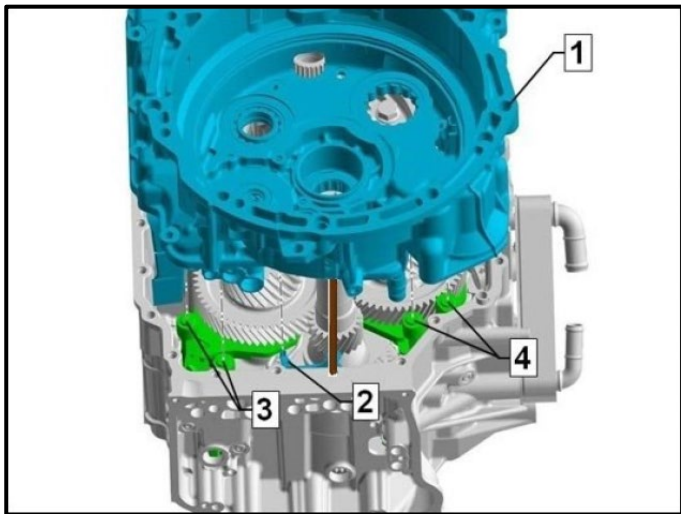

### Reassemble gearbox housing:

- Reference the previously made marks and reinstall guide pins -T40288- into the gearbox housing (if the guide pins were previously removed).
- With the assistance of a second technician, carefully install clutch housing <1> on roller bearings in gearbox housing.
- When installing, pay attention to injection pipe <2> and selector forks <3> and <4>.
- With minimal corrections and shaking lightly, fit housing sections together until air gap between housings is 0 mm.
- If an air gap of 0 mm is not attained, lift clutch housing <1> again and check positions of injection pipe <2> and selector forks <3> and <4>, and correct if necessary.
- Again with minimal corrections and shaking lightly, fit housing sections together until air gap is 0 mm.
- Unscrew guide pins -T40288-.
- Screw in new bolts <1 to 22> from repair kit for housing hand tight on clutch end.

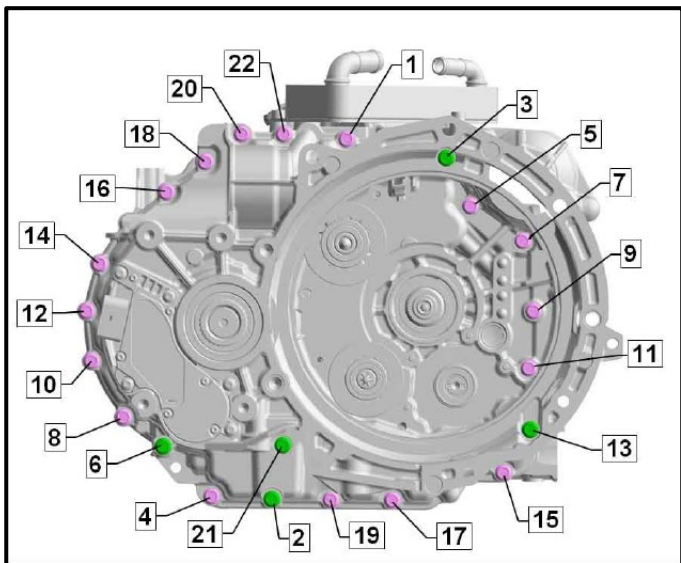

### NOTE

Note the different bolt lengths:

- Pink bolts = M8x38
  - Green bolts = M8x75
- After all bolts are hand tight, torque the bolts as follows in sequence <1 to 22>:
    - 1<sup>st</sup> stage = 20 Nm.
    - 2<sup>nd</sup> stage = 90°
  - The gearbox can now be moved to the engine stand for final assembly.

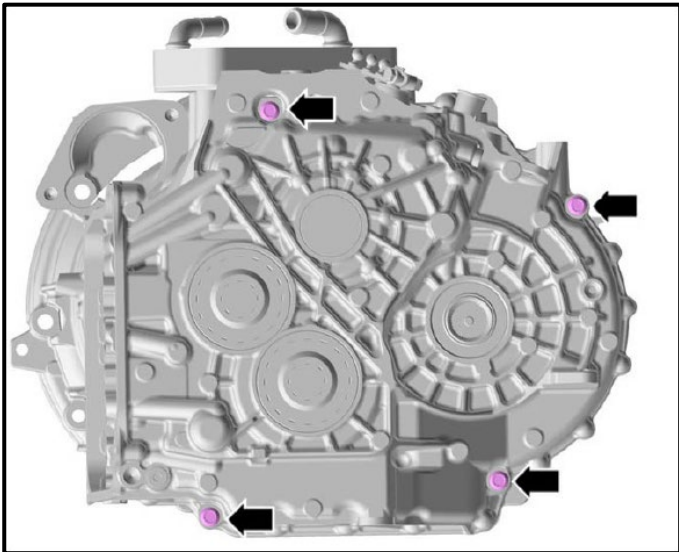

- Install new bolts <arrows> from the repair kit and torque to 20 Nm + 90°.

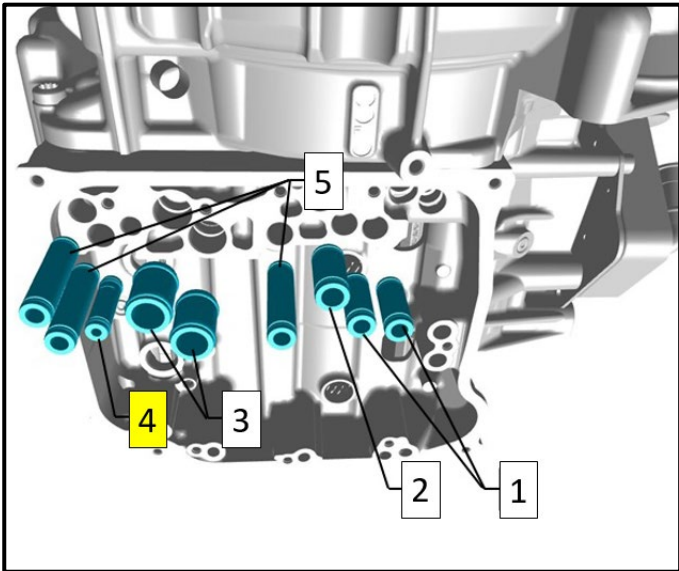

**Install new oil guide tubes:**

- Lubricate new oil guide tubes lightly with gearbox oil before installing.
- Install new oil guide tubes <1 to 5> from the repair kit.

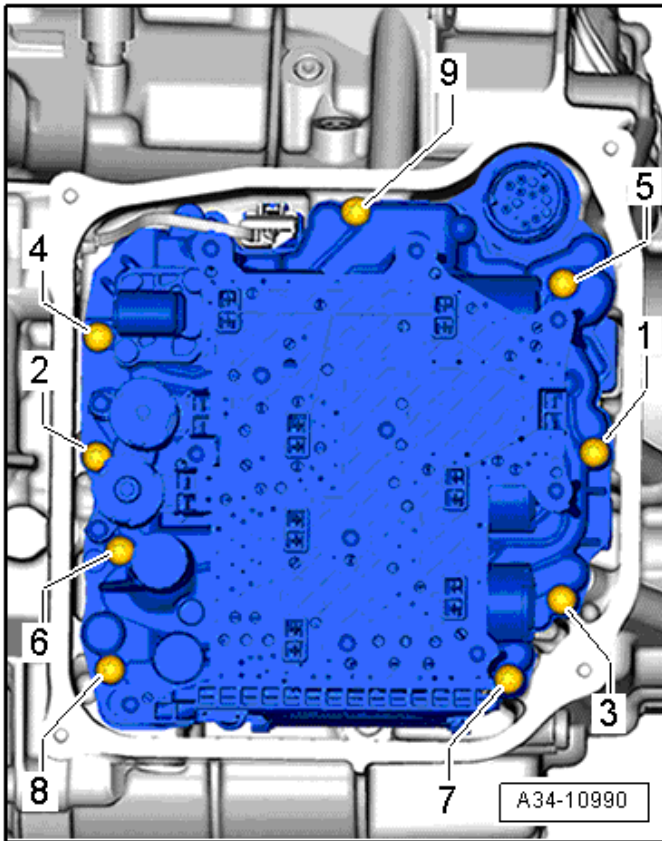

### Reinstall Mechatronic:

- Installation is the reverse order of removal.
- Use new bolts from the repair kit.
- Tighten bolts as follows in sequence <1 to 9>:
  - 1<sup>st</sup> stage = by hand
  - 2<sup>nd</sup> stage = 8 Nm
  - 3<sup>rd</sup> stage = 45°

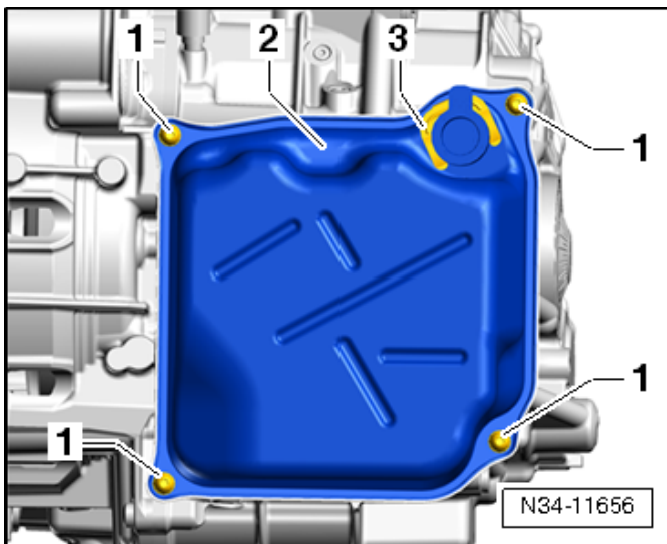

### Install new cover:

- Clean the sealing surface on the gearbox housing of oil and grease.
- Coat the O-ring with new gear oil.
- Install new cover from repair kit in the reverse order of removal.
- Tighten new bolts from repair kit diagonally in multiple steps and torque to 8 Nm + 60°.
- Install new clamp <3>.

Part Number	Part Description
0BH-325-147	Retaining clamp

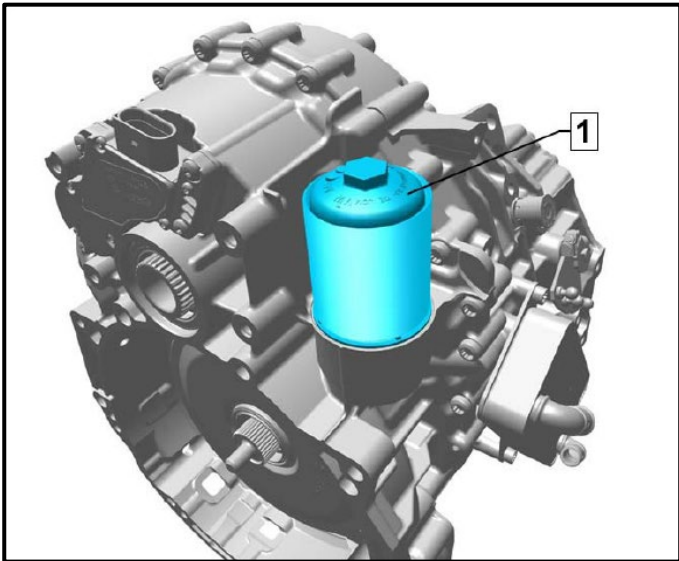

#### Install new gear oil filter from repair kit:

- Coat O-ring with new gear oil.
- Install new gear oil filter and housing and torque to 50 Nm.

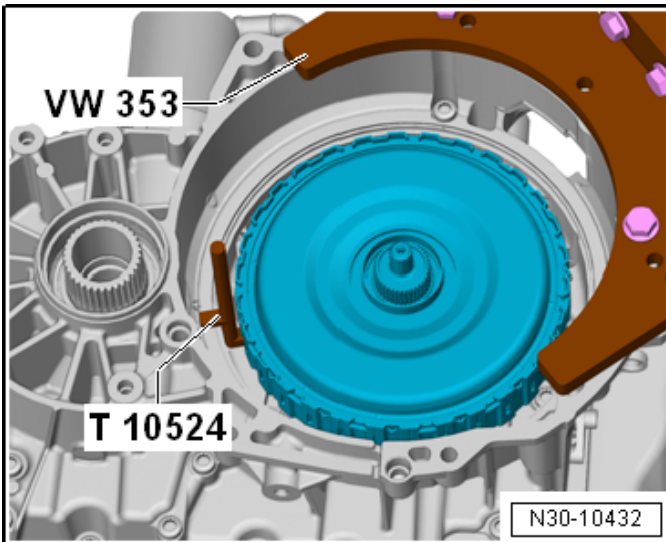

#### Install dual clutch:

- See ELSA Repair Manual: *Repair manual > Drivetrain > 7-Speed DSG Transmission OGC > 30 Clutch > Clutch > Dual Clutch, Installing*
- Use new circlip from repair kit.

#### NOTE

The dual clutch does not need to be re-adjusted; the retaining ring can be re-used, contrary to the information in the Repair Manual.





#### Install new oil seals:

- Reference ELSA Repair Manual: *Repair manual > Drivetrain > 7-Speed DSG Transmission OGC > 39 Final Drive, Differential > Seals*

#### NOTE

The repair kit can be used for vehicles with front-wheel drive or all-wheel drive and includes three seals; please make sure that there is always one oil seal left over.

AWD vehicles:

- Left seal p/n = 0BH-409-400-E
- Right seal p/n = 02Q-409-189-A

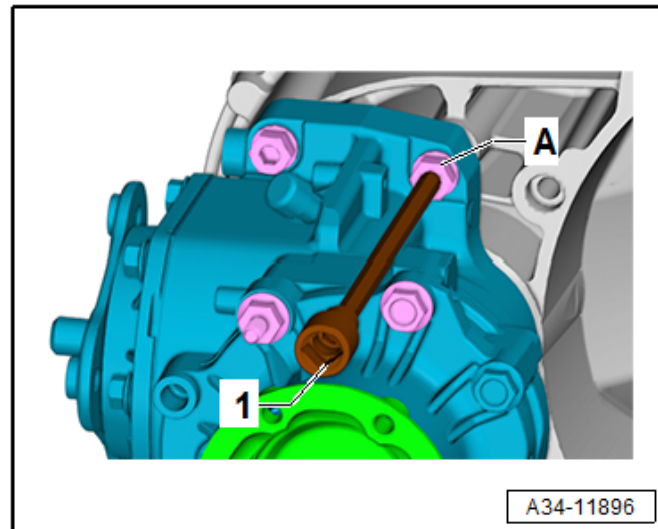
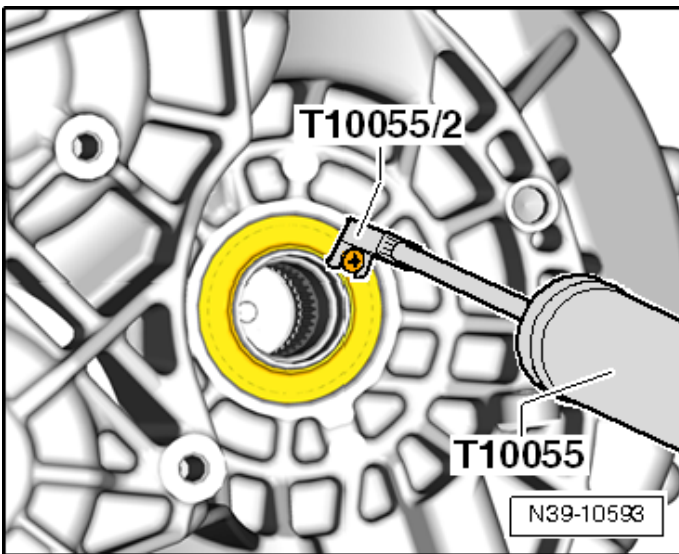

#### Reinstall bevel box:

- See ELSA Repair Manual: *Repair manual > Drivetrain > 7-Speed Dual Clutch Transmission OGC > 34 Controls, Housing > Bevel Box > Bevel Box, Installing*
- Use new bolts.



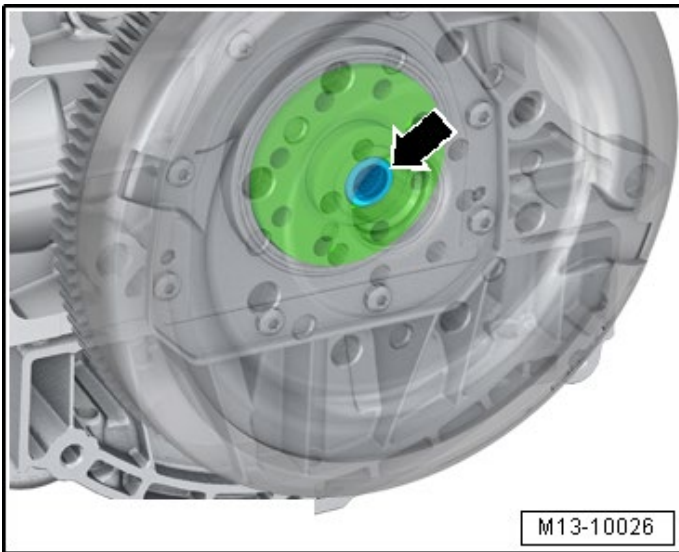

#### Replace crankshaft needle bearing:

- Reference ETKA for the correct needle bearing part number.
- See ELSA Repair Manual: *Repair manual > Engine > 4-Cylinder Direct Injection (2.0L, 4V, Turbocharger, Chain Drive, Generation III) - R Models > 13 Crankshaft, Cylinder Block > Crankshaft > Crankshaft Needle Bearing, Replacing*

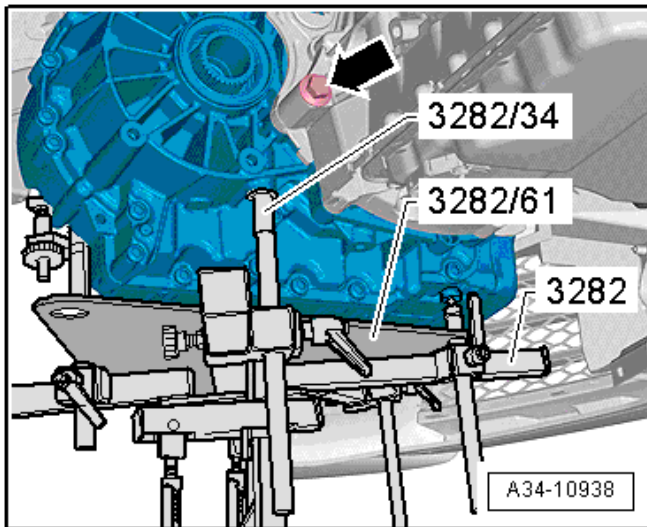

#### Reinstall transmission:

- See ELSA Repair Manual: *Repair manual > Drivetrain > 7-Speed DSG Transmission 0GC > 34 Controls, Housing > Transmission, Removing and Installing > Transmission, Installing*

## Clear TCM DTC memory and perform basic settings:

- Connect diagnostic tester to the vehicle.
- Perform a full vehicle scan using Diagnosis.
- Switch to Self-diagnosis.
- Select “Basic Setting” for 0002 – Transmission electronics.

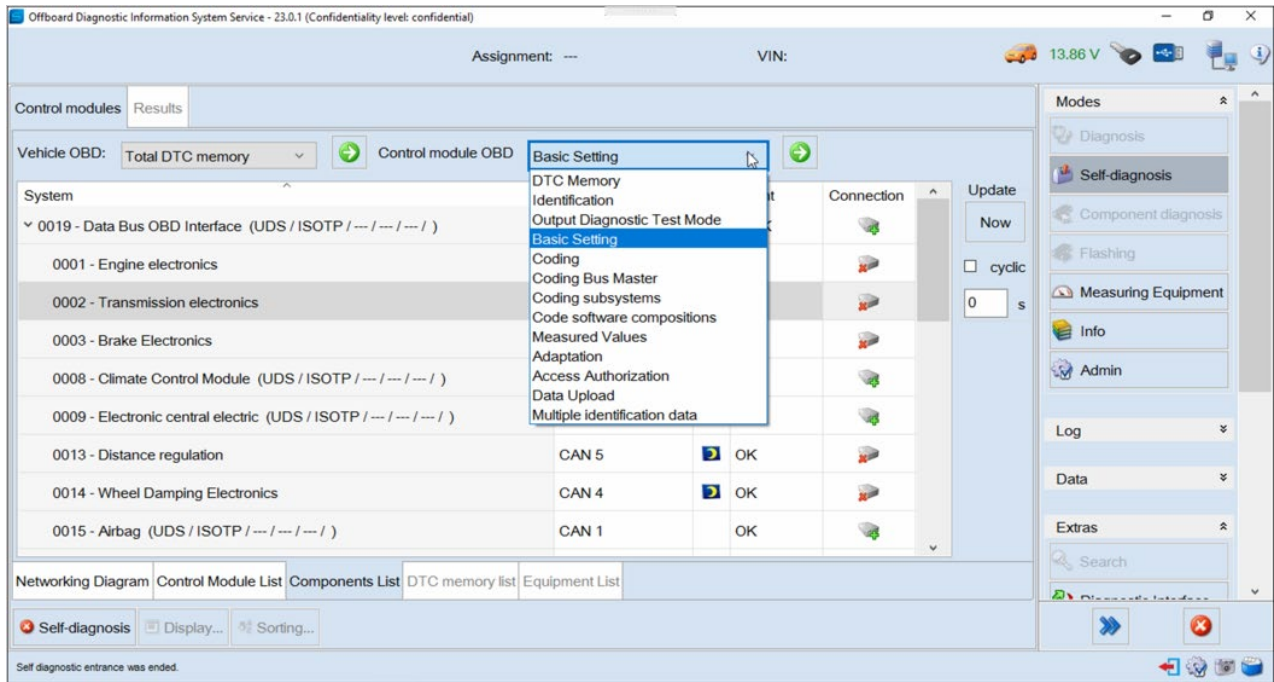

- Move basic setting, “[VO]\_Clear\_cover\_plate\_failure\_of\_auxilliary\_fluid\_pump” to the selection box.
  - The basic setting can be moved by double clicking the basic setting, or by clicking on arrow <1>.

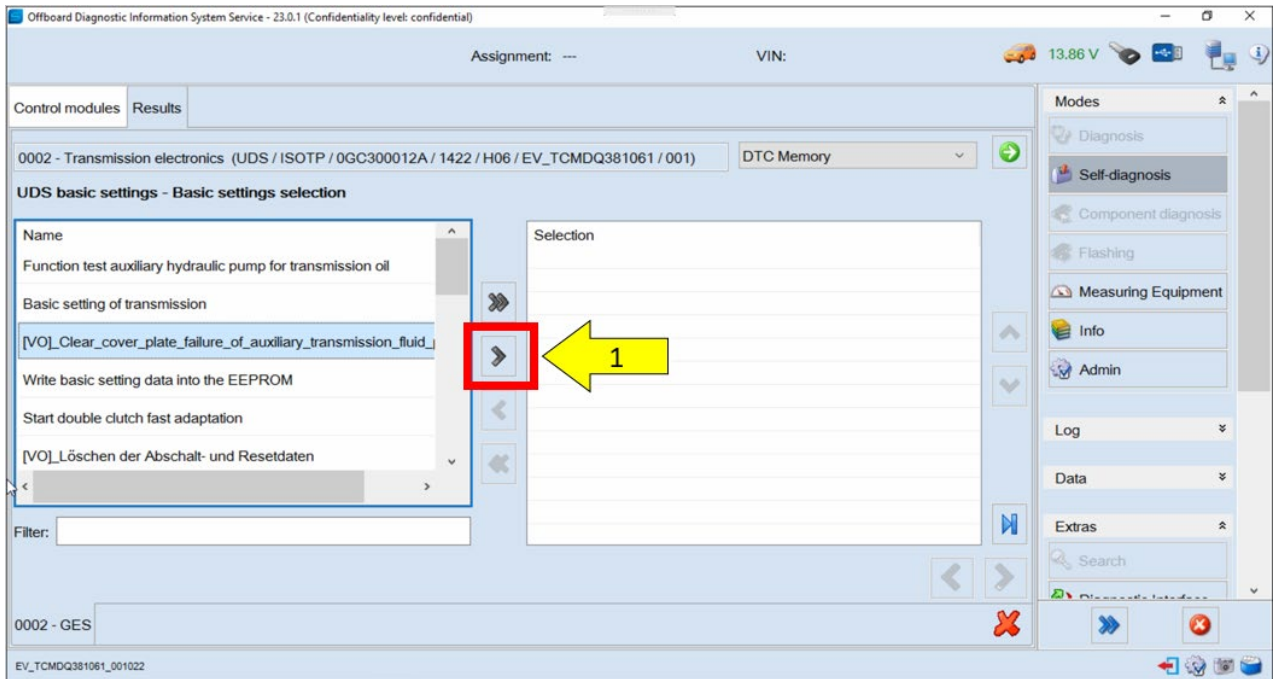

- Once the basic setting is in the selection box, continue by clicking the blue forward arrow <1>.

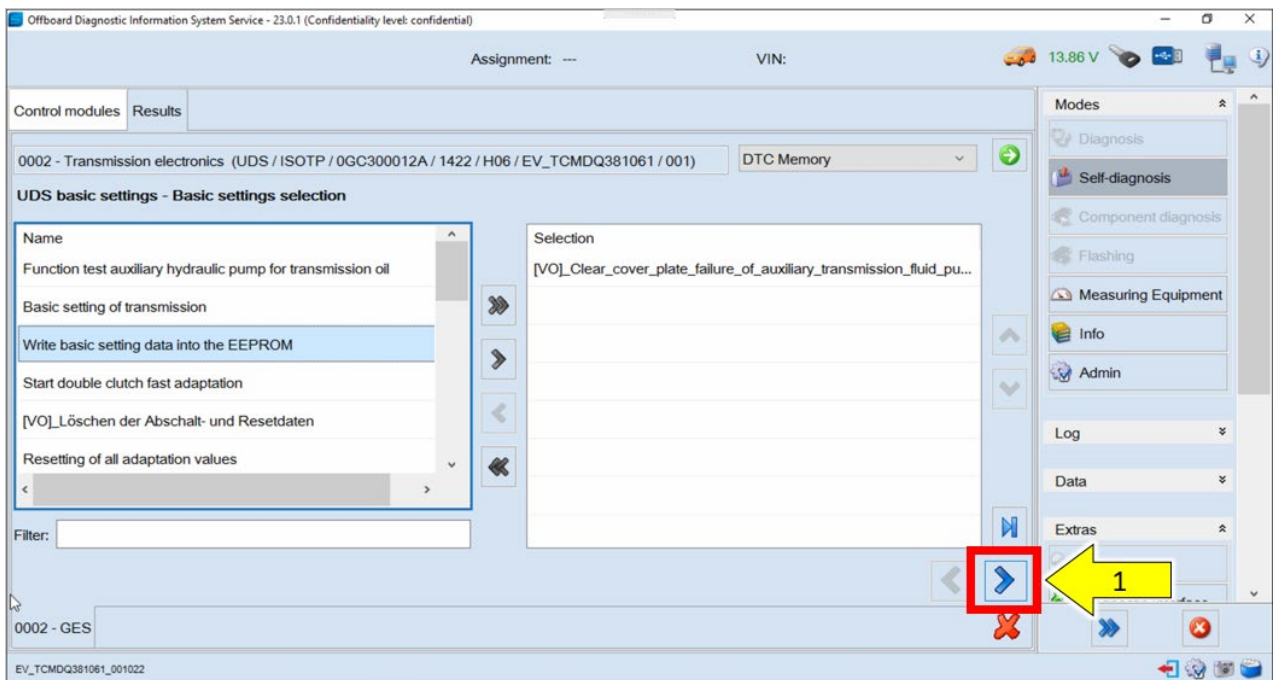

- Click in the empty “Value” box and select “not available” <1>.
- Continue by clicking the blue forward arrow <2>.

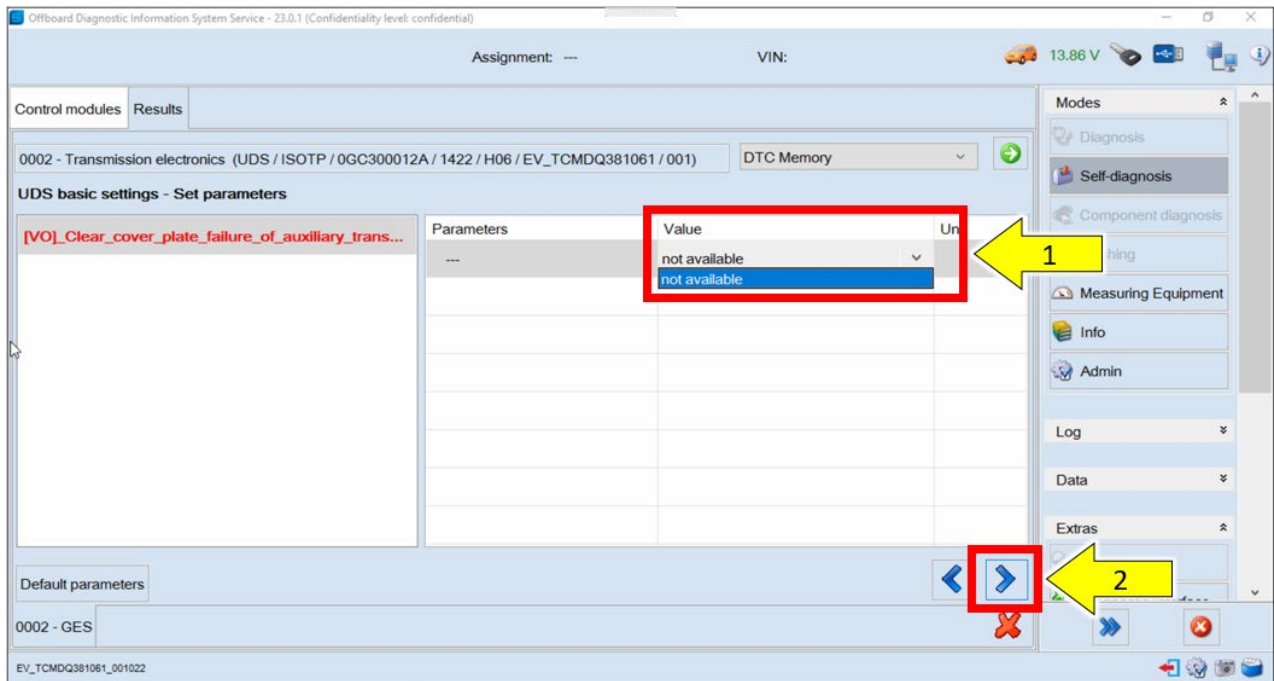

- All measured values will need to be moved to the selection box, and measured value “[VO]\_Auxilliary\_transmission\_fluid\_pump\_cover\_plate\_diags\_number” will need to be listed first.
  - Type “fluid” in the filter box and move measured value, “[VO]\_Auxilliary\_transmission\_fluid\_pump\_cover\_plate\_diags\_number” to the selection box.
  - Then delete “fluid” from the filter box and move all of the remaining measured values to the selection box.
  - Once all measured values are in the selection box, click on the blue forward arrow <1>.

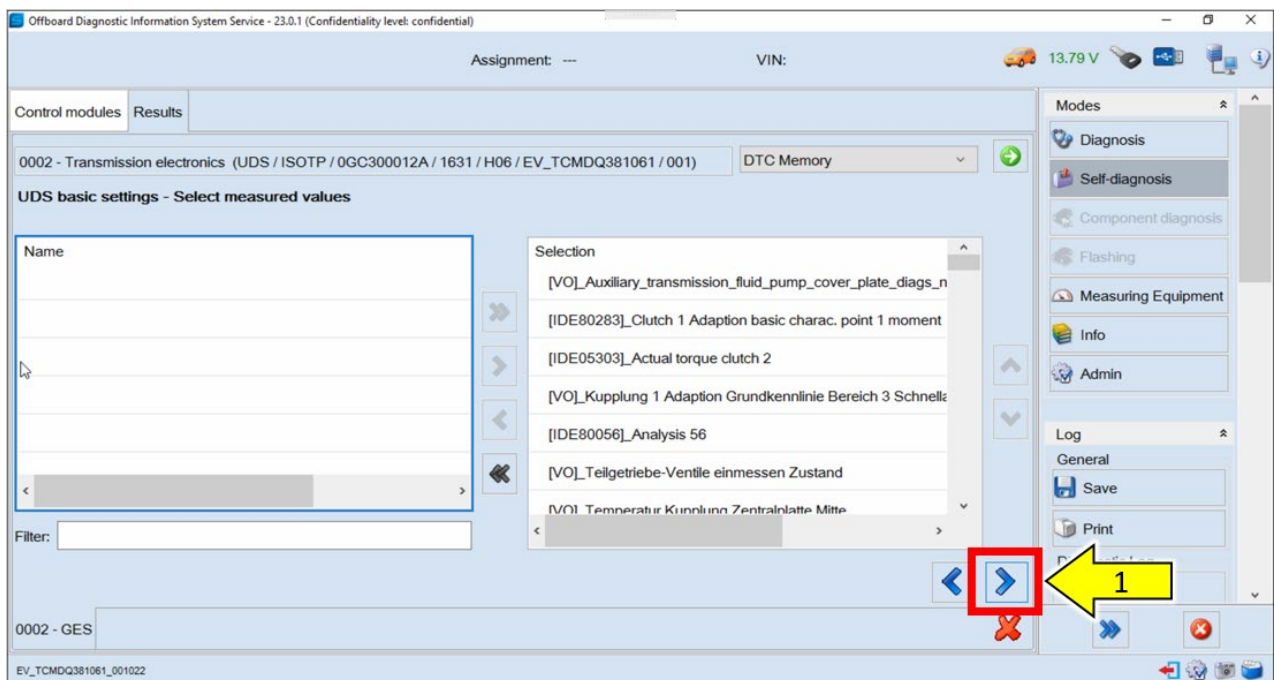



- Click “Start” <1> to begin the basic setting routine.
- Once the basic setting is complete, the event memory entry will then be set to “intermittent” and can be erased.

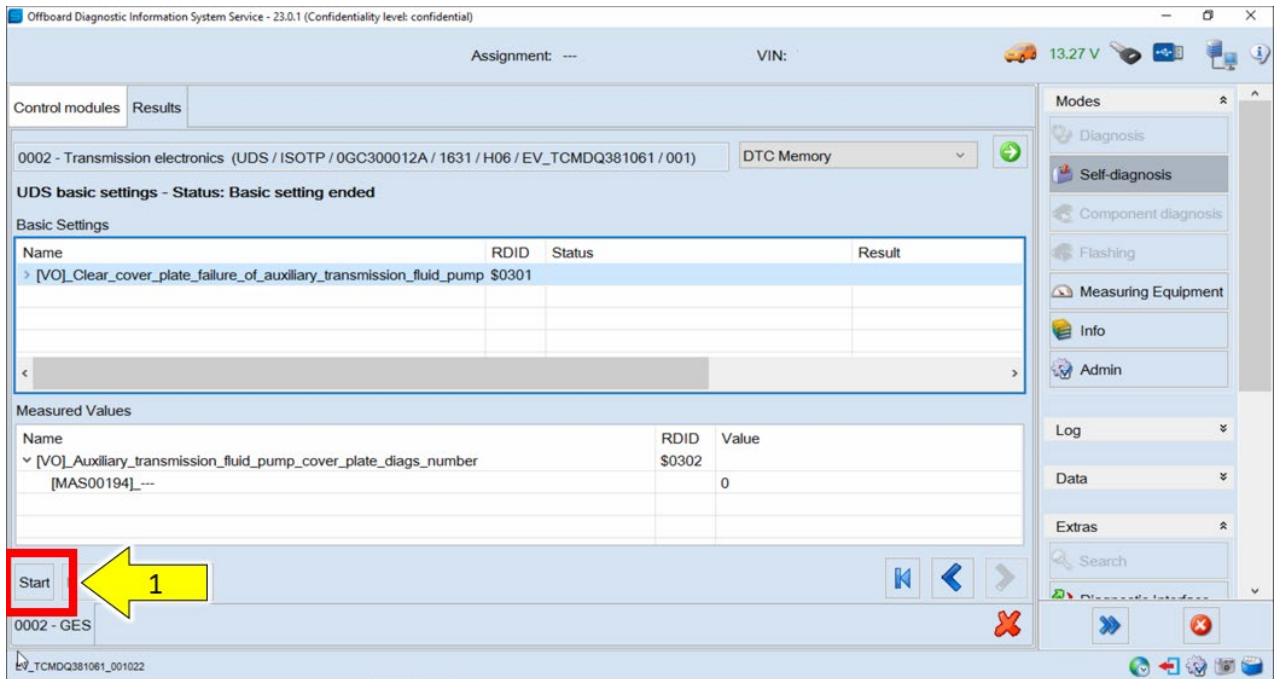

- Once the fault is erased, switch to Operating Mode “Diagnosis.”
- Select Guided Functions test plan, “02 – Basic Setting” <1>.
- Follow the on-screen prompts.

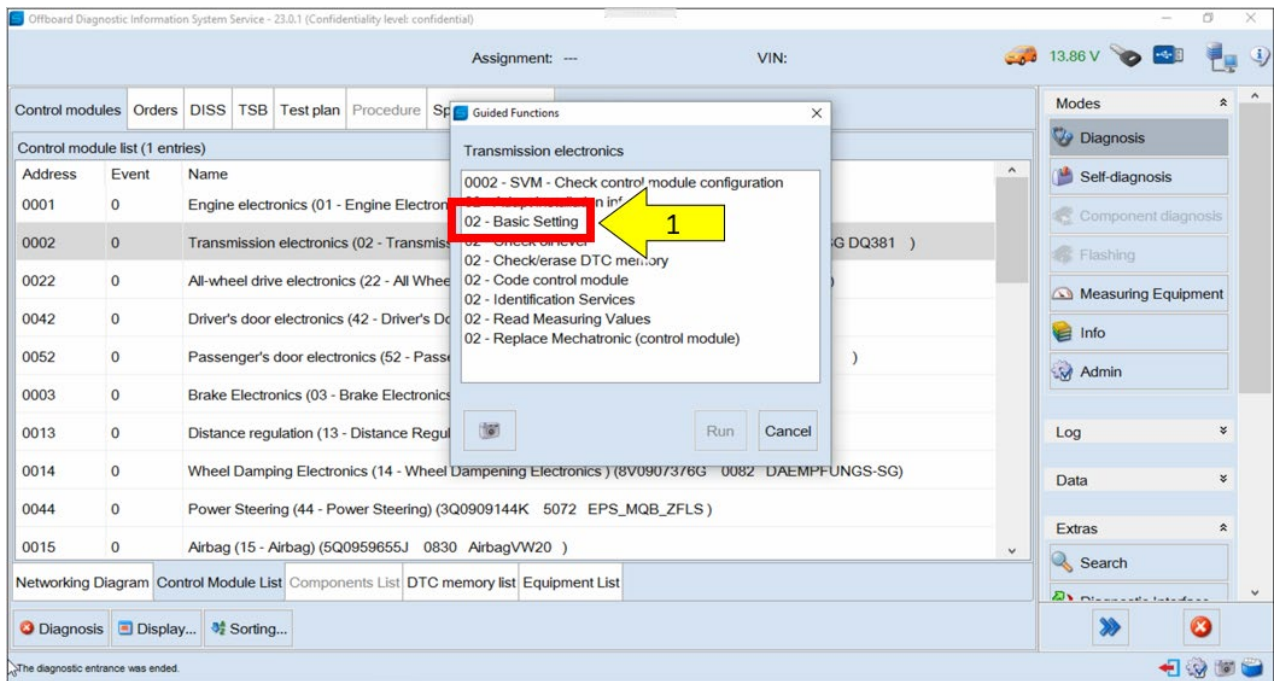

- Perform the following basic settings in sequence and follow the on-screen prompts:
  - Transmission basic setting
  - Adaptation drive of transmission

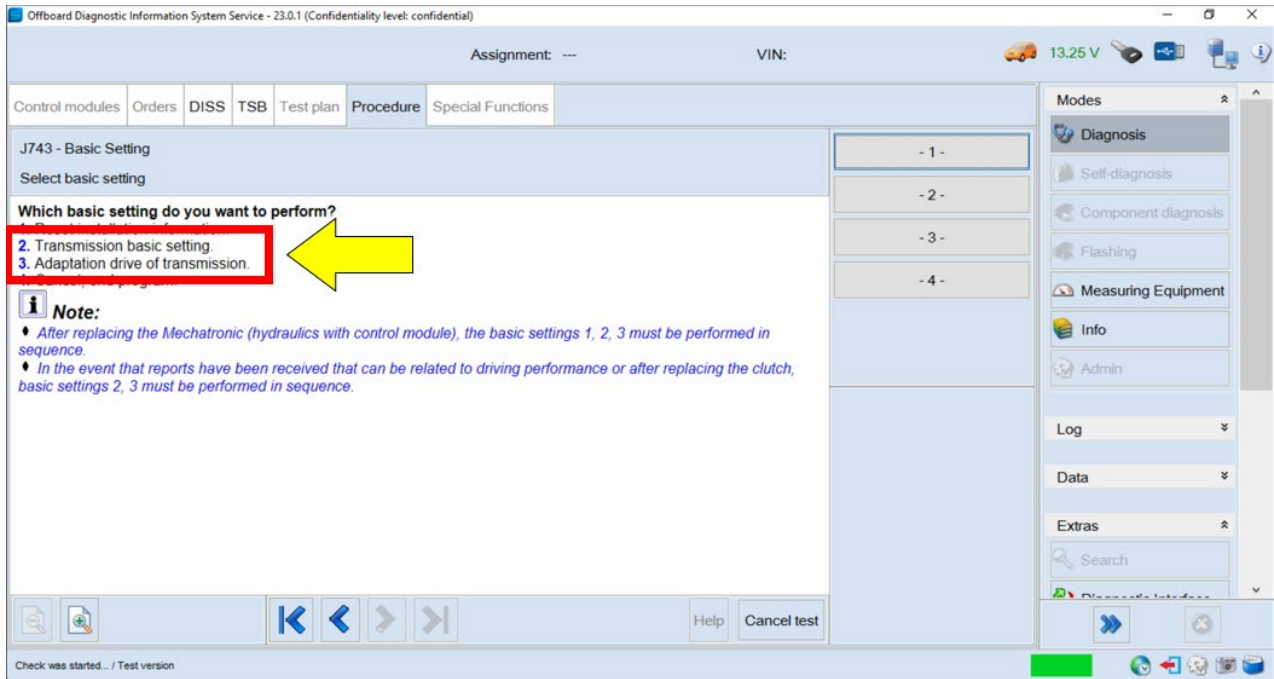

- Pay close attention to the information found in the Function test guides before performing the “Adaptation drive of transmission” basic setting.

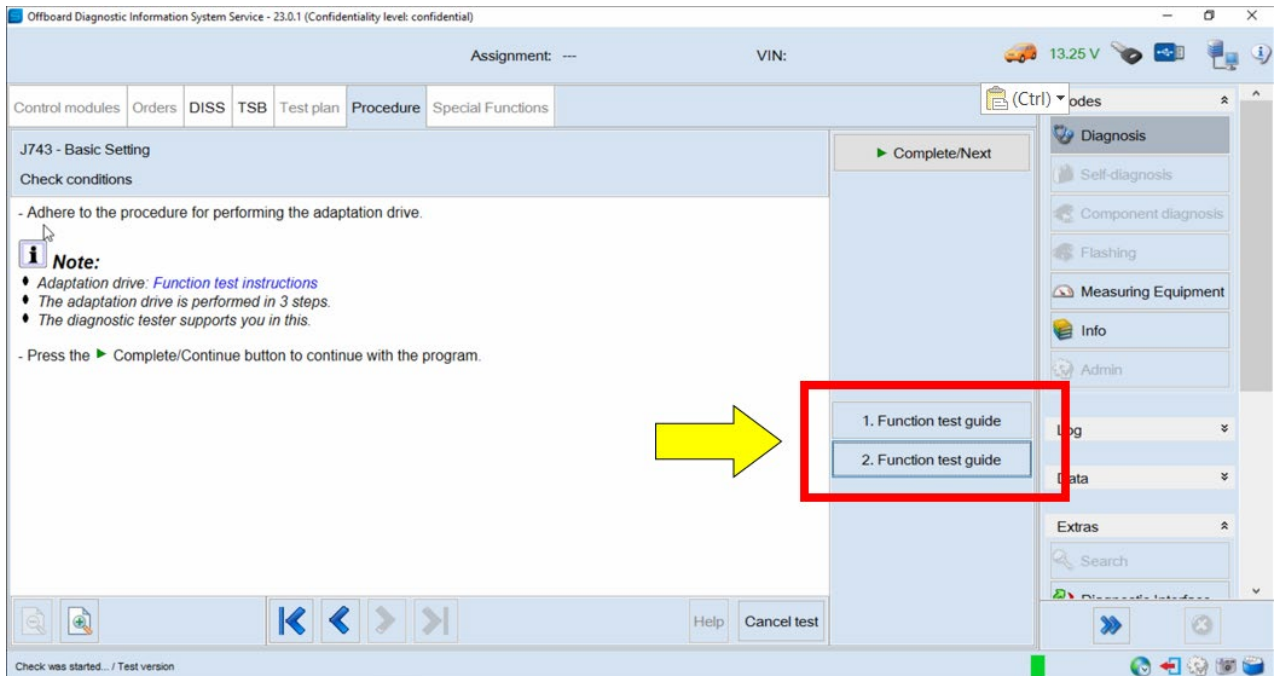

**After basic settings are complete, Proceed to Section D.**

## Section D – Campaign Completion Stamp

I certify that this campaign  
has been performed in strict  
accordance with the applicable  
Audi repair procedure.

SAGA Code: \_\_\_\_\_  
Technician: \_\_\_\_\_  
Date: \_\_\_\_\_

Item#: AUD4927ENG

-OR-

Je certifie que cette  
campagne de rappel a été  
exécutée suivant les strictes  
directives de réparation  
d'Audi

Code de SAGA: \_\_\_\_\_  
Technicien: \_\_\_\_\_  
Date: \_\_\_\_\_

Item # AUD4927FRE

- Once the campaign has been completed, the technician should stamp the repair order.
- Stamps are available for ordering through the Compliance Label Ordering Portal.
- **Proceed to Section E**

## Section E - Parts Return/Disposal

Properly store (retain), destroy or dispose of removed parts in accordance with all state/province and local requirements, unless otherwise indicated and/or requested through the Warranty Parts Portal (WPP) for U.S. and the Part Destruction and Core Disposition Report for Canada.