

**37-23-01 - Transmission Control Module -J217- with fault code P0C29 after performing Service Action 34K1**

Release date: 8/10/2023

**Condition**

Applicable Vehicles					
Model(s)	Year	Eng. Code	Trans. Code	VIN Range From	VIN Range To
Golf R	2018	2.0T (DJJA)	DSG (0GC)	AU_JW035525	AU_JW181595

Revision Table			
Instance Number	Published Date	Version Number	Reason For Update
2070973/1	8/10/2023	37-23-01	Original publication.

DTC	Description
P0C29	Activation of auxiliary hydraulic pump for gear oil, implausible
P175E *	Clutch 1 closes unintentionally
P176F *	Clutch 2 closes unintentionally
P175D *	Clutch 1 opens unintentionally
P176E *	Clutch 2 opens unintentionally
P072C *	Gear 1 not adjustable
P176A *	Gear positioner 1 cannot be regulated
P176B *	Gear positioner 2 cannot be regulated
P176C *	Gear positioner 3 cannot be regulated
P176D *	Gear positioner 4 cannot be regulated
P072B *	Gear R not adjustable

**37-23-01 - Transmission Control Module -J217- with fault code P0C29 after performing Service Action 34K1**

Release date: 8/10/2023

P0810 *	Clutch control malfunction
P0607 *	Control module implausible
P1899 *	Clutch 2 function restriction

\* Faults may appear in conjunction with P0C29 but P0C29 must be present for the TSB to apply.

## Technical Background

Transmission sets fault code P0C29 (the other faults mentioned above may be present as consequential to P0C29) after previously performing Service Action 34K1.

**Note:**

**DO NOT** diagnose or replace transmission due to DTC faults P0C29, P175E, P176F, P175D, P176E, P072C, P176A, P176B, P176C, P176D, P072B, P0810, P0607 and/or P1899 **before** performing the update function as explained in this bulletin.

## Production Solution

Optimized auxiliary hydraulic pump 1 for gearbox oil -V475- from gearbox production date: 01.10.2017.

## Service

If the vehicle has P0C29 (the other faults mentioned above may be present as consequential to P0C29) after performing Service Action 34K1, please reference Section C of Service Action 34K1 for repair instructions.

**Note:**

A video of the repair can also be found at: <https://vwcup.track360.com/library/13062>





37-23-01 - Transmission Control Module -J217- with fault code P0C29 after performing Service Action 34K1

Release date: 8/10/2023

### Warranty

<b>To determine if this procedure is covered under Warranty, always refer to the Warranty Policies and Procedures Manual <sup>1)</sup></b>					
Model(s)	Year(s)	Eng. Code(s)	Trans. Code(s)	VIN Range From	VIN Range To
Golf R	2018	2.0T (DJJA)	DSG	AU_JW035525	AU_JW181595
<b>SAGA Coding</b>					
<b>Claim Type:</b>	Use applicable Claim Type <sup>1)</sup>				
<b>Service Number:</b>	<b>Damage Code</b>		<b>HST</b>	<b>Damage Location (Depends on Service No.)</b>	
3479	0010		--	Use applicable when indicated in Elsa (L/R)	
<b>Parts Manufacturer</b>		Golf R		VWV <sup>2)</sup>	
<b>Labor Operation <sup>3)</sup></b> : Remove and Install transmission			34351942 = Elsa for latest time units		
<b>Labor Operation <sup>3)</sup></b> : Replace auxiliary hydraulic pump			34354299 = 380 TU		
<b>Labor Operation <sup>3)</sup></b> : Connect battery charger			27068950 = Elsa for latest time units		
<b>Causal Part:</b>			0GC 398 008 D		
<b>Diagnostic Time <sup>4)</sup></b>					
<b>GFF Time expenditure</b>	01500000 = Up To 50 TU		YES		
<b>Road Test</b>	01210004 = 10 TU		YES		
<b>Technical Diagnosis</b>	01320000 = 00 TU max.		NO		
<b>Claim Comment:</b> Input "As per Technical Bulletin 2070973" in comment section of Warranty Claim.					



**37-23-01 - Transmission Control Module -J217- with fault code P0C29 after performing Service Action 34K1**

Release date: 8/10/2023

- 1) Vehicle may be outside any Warranty in which case this Technical Bulletin is informational only.
- 2) Code per warranty vendor code policy.
- 3) Labor Time Units (TUs) are subject to change with ELSA updates.
- 4) Documentation required per Warranty Policies and Procedures Manual.

**Required Parts and Tools**

Part No:	Part Description	Quantity
0GC398008D	REPAIR KIT	1
01M323255	ROUND SEAL	2
06B105313D	NEEDLE BEARING	1
0BH325147	RETAINING CLIP	1
0GC927377	GASKET	1
1K0253141AA	DUAL CLAMP	1
7E0407297	LOCK RING	2
D 174003M2	SILCONE SEALANT	1
G 055128A1	SEAL GREASE	.10
G 12E100S1	COOLANT (1 gallon concentrate)	Up to 40.00
G 055529A2	GEAR OIL	7
N 0150816	SHOULDERED HEX. NUT	2
N 10332002	SHOULDERED HEX. NUT	6
N 10552402	BOLT, HEX. HD. WITH SHOULDER	2
N 10552404	BOLT, HEX. HD. WITH SHOULDER	3
N 10784701	BOLT	1
N 10784801	SCREW	1



37-23-01 - Transmission Control Module -J217- with fault code P0C29 after performing Service Action 34K1

Release date: 8/10/2023

N 10785401	HEXAGON FLANGE SCREW (COMBI)	6
N 90846102	12 POINT SOCKET HEAD SCREW	3
N 90965401	PLUG WITH SEAL	1
N 90991102 or N 91108201	BOLT, WITH POLYGON SOCKET HD. (driveshaft bolts – confirm part number in ETKA)	6
N 91066901	BOLT, HEX. HD. WITH SHOUL (COMBI)	4
N 91088901	SOCKET HD. SCREW WITH COLLAR	4
N 91201001	BOLT, HEX, HD. (COMBI)	1
N 91231201	SCREW	4
WHT000729A	HEX SOCKET HEAD BOLT (COMBI)	5
WHT005179	12 POINT SOCKET HEAD SCREW	3

**Part numbers are accurate at time of publication. Always refer to ETKA for the latest part information.**

Tool Description	Tool No:
Midtronics Battery Tester/Charger	GRX3000VAS or MTRMSP0702 battery maintainer/charger
VAS Diagnostic Tool	VAS 6150/X & VAS 6160/X and ODIS Service with: current online updates

### Additional Information

All part and service references provided in this Technical Bulletin are subject to change and/or removal. Always check with your Parts Dept. and Repair Manuals for the latest information.

## Replacing Auxiliary Hydraulic Pump



A video outlining replacement of the auxiliary hydraulic pump is available.

Click on the link below or scan the QR code to access the video.

<https://vwcup.track360.com/library/13062>



### NOTE

If internal or external damage caused by the auxiliary hydraulic pump bolts coming loose is found before or during the repair:

- Take clear photos
- U.S. dealers: Create a WISE Campaign Authorization request and attach photos for review.
- Canadian dealers: Create a TAC WEB ticket with the photos attached for review.

### Drain gear oil:

- See ELSA Repair Manual: *Repair manual > Drivetrain > 7-Speed DSG Transmission 0GC > 34 Controls, Housing > Transmission Fluid > Transmission Fluid, Draining and Filling*

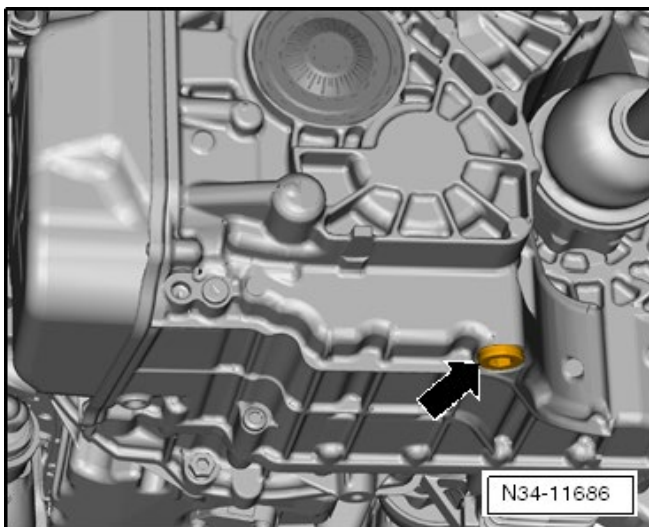

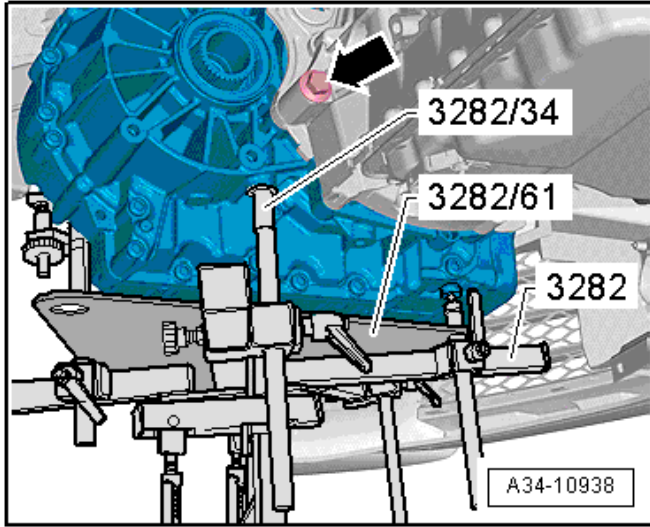

#### Remove transmission:

- See ELSA Repair Manual: *Repair manual > Drivetrain > 7-Speed DSG Transmission 0GC > 34 Controls, Housing > Transmission, Removing and Installing > Transmission, Removing, Vehicles with Gasoline Engine*

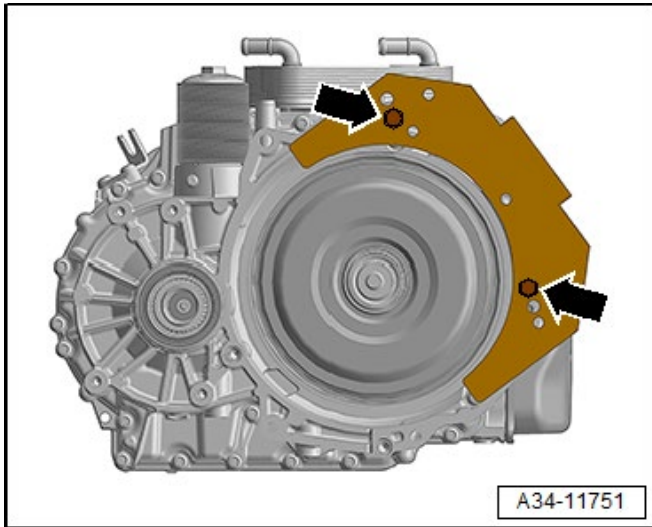

#### Secure transmission to stand:

- See ELSA Repair Manual: *Repair manual > Drivetrain > 7-Speed DSG Transmission 0GC > 34 Controls, Housing > Securing on Engine and Transmission Holder*

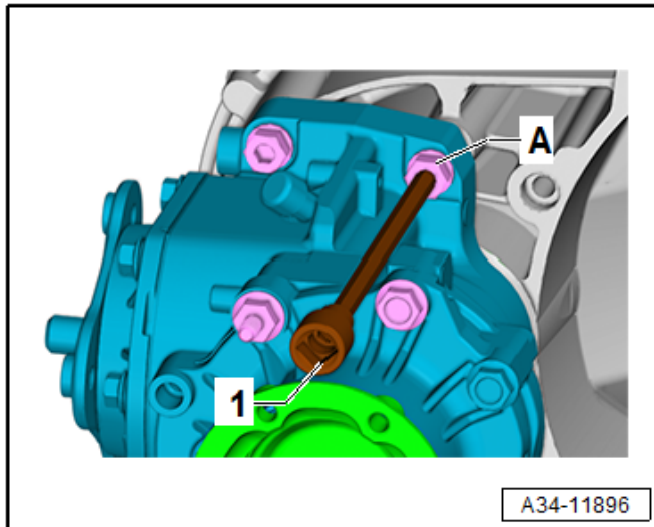

#### Remove bevel box:

- See ELSA Repair Manual: *Repair manual > Drivetrain > 7-Speed DSG Transmission 0GC > 34 Controls, Housing > Bevel Box > Bevel Box, Removing*

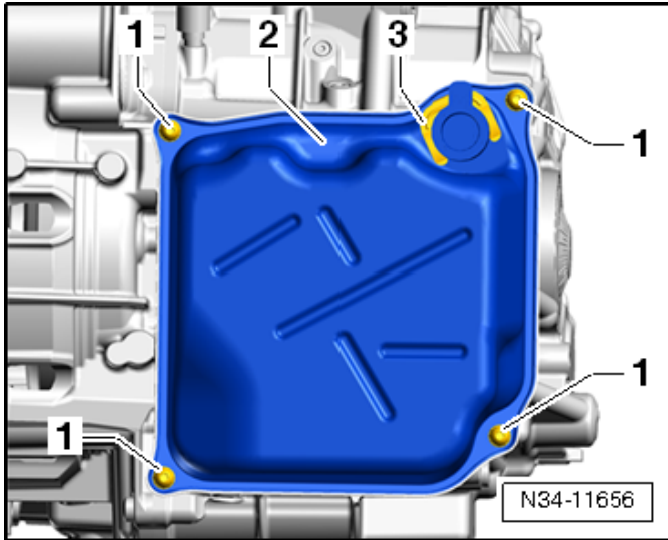

#### Remove transmission oil pan:

- Place used oil collection container under the transmission.
- Remove the clamp <3>.
- Loosen and remove the screws <1> in a diagonal sequence.
- Remove the oil pan <2> and if necessary loosen the oil pan by hitting lightly with a rubber hammer.

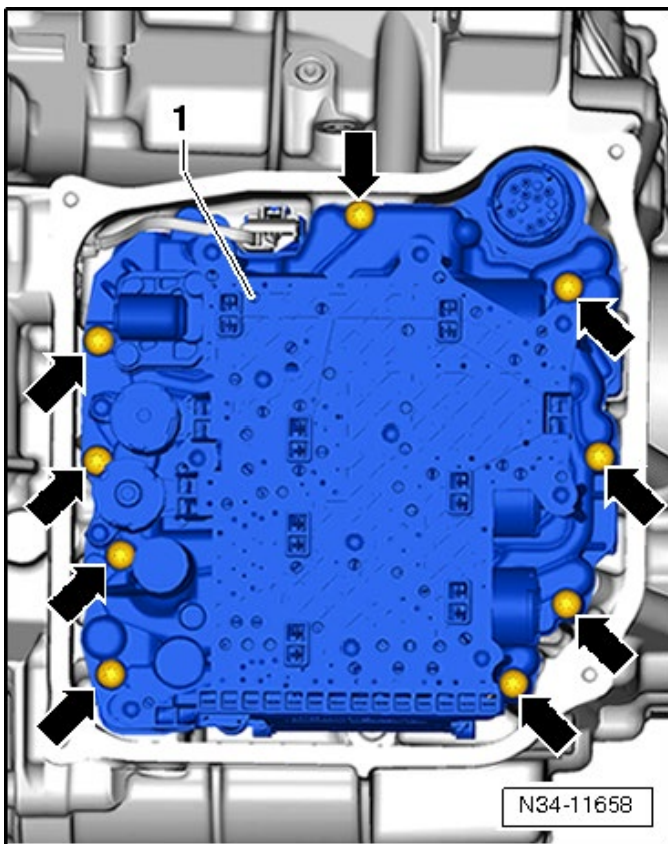

#### Remove mechatronic:

- Loosen and remove the screws <arrows> in a diagonal sequence.
- Carefully remove the mechatronic <1>.



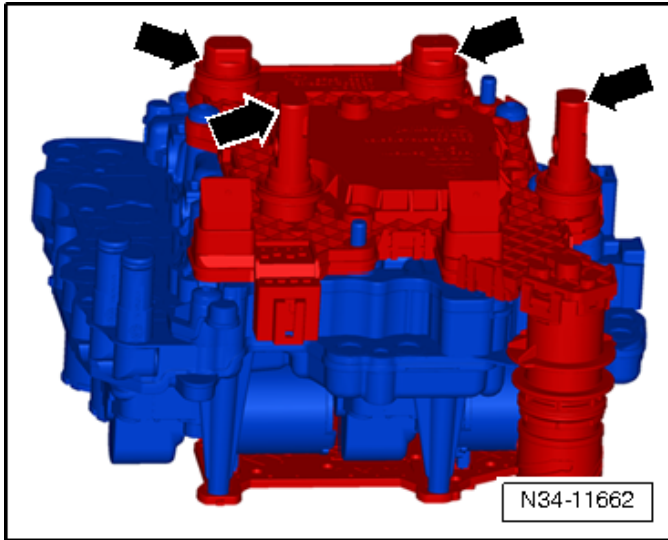

**Store the Mechatronic properly:**

- Store the Mechatronic so that the sensors <arrows> face upward.
- Place and cover the mechatronic on clean, lint free cloths.

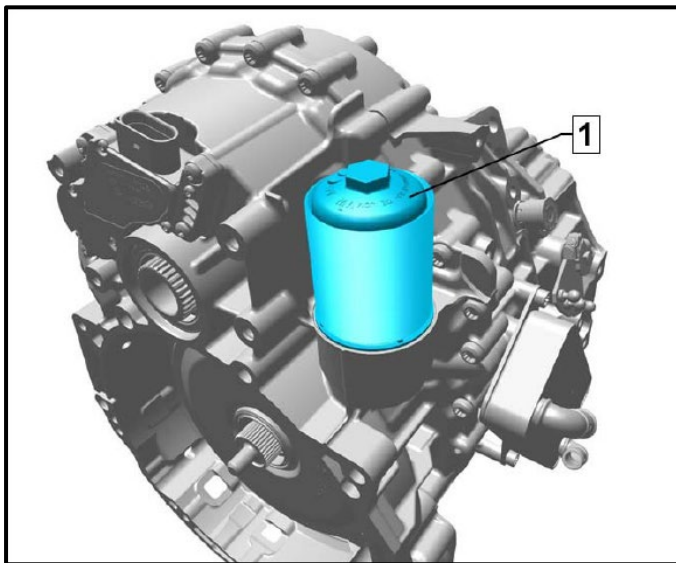

**Remove gear oil filter:**

- Remove gear oil filter housing <1> and filter.

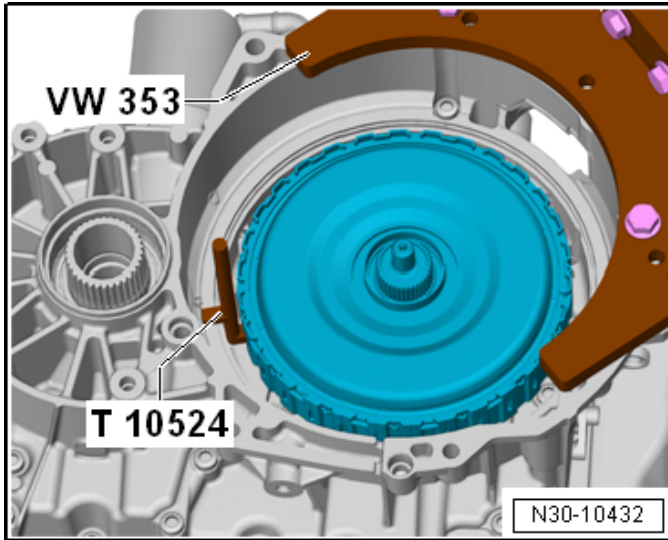

**Remove dual clutch:**

- See ELSA Repair Manual: *Repair manual > Drivetrain > 7-Speed Dual Clutch Transmission 0GC > 30 Clutch > Clutch > Dual Clutch, Removing*

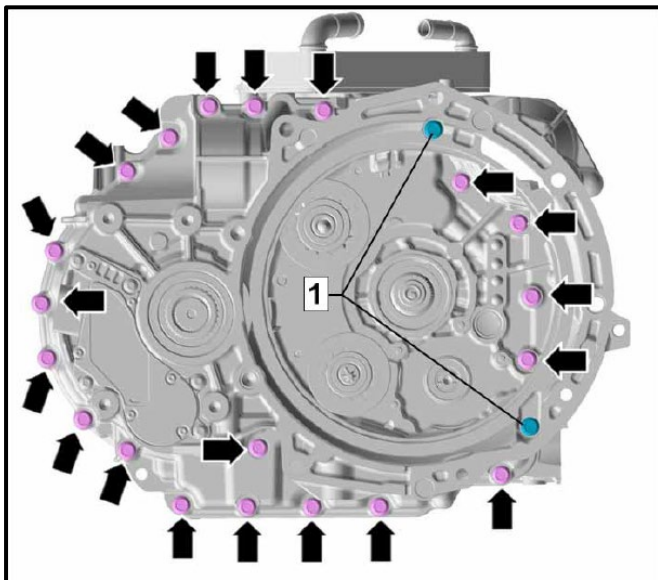

**Remove housing bolts on clutch side:**

- **DO NOT REMOVE BOLTS <1>.**
- Remove bolts <arrows>.
- Note the lengths of the removed bolts. There are two different length bolts.

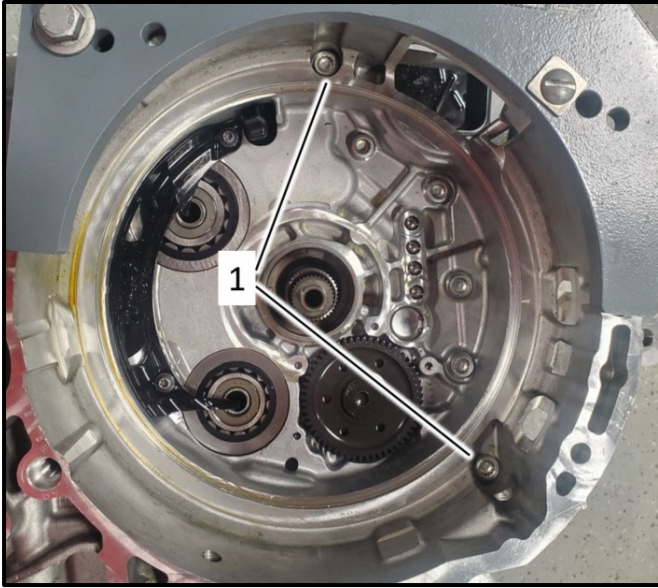

- Alternate view of the two bolts <1> that are not removed at this time.

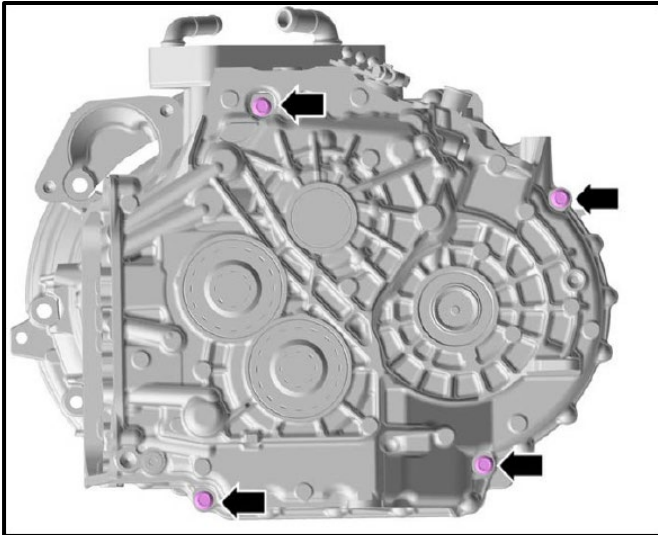

**Remove housing bolts on gearbox side:**

- Rotate transmission on stand.
- Remove bolts <arrows>.



**Move transmission:**

- Move transmission to a suitable work bench or cart.
- The splined shaft must face upward.
- Support the transmission from tipping using wood blocks as needed.

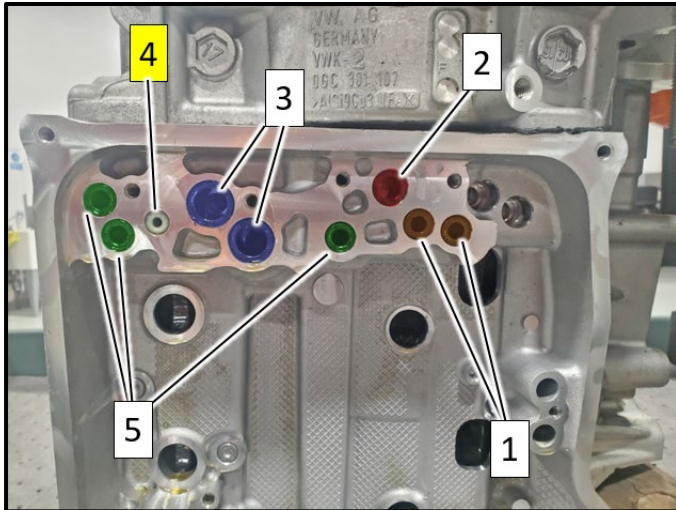

**Remove oil guide tubes:**

- Loosen each oil tube by turning slightly using suitable circlip pliers.
- Then pull each oil tube out.
- Screw a suitable self-tapping screw or wood screw into the oil tube <4>, loosen the tube and then pull it out.

**NOTE**

When removing the oil tubes, parts of the seals can become cut off. Make sure there are no seal pieces left in the gearbox.

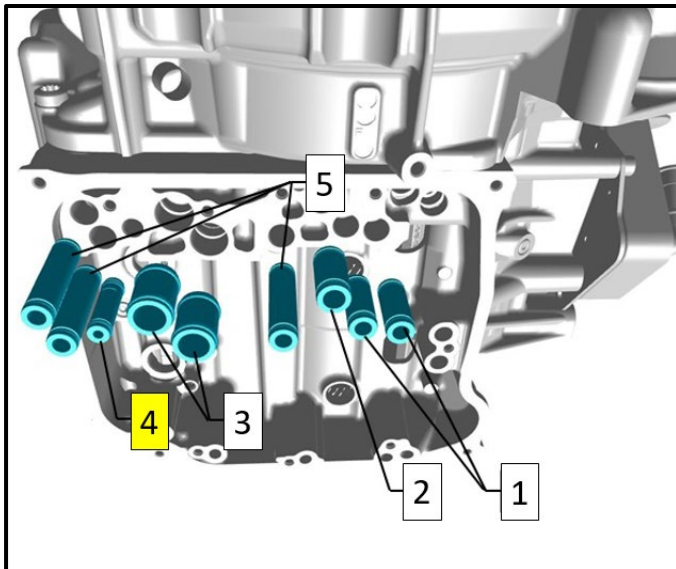

**Remove remaining two housing bolts:**

- Remove bolts <arrows>.

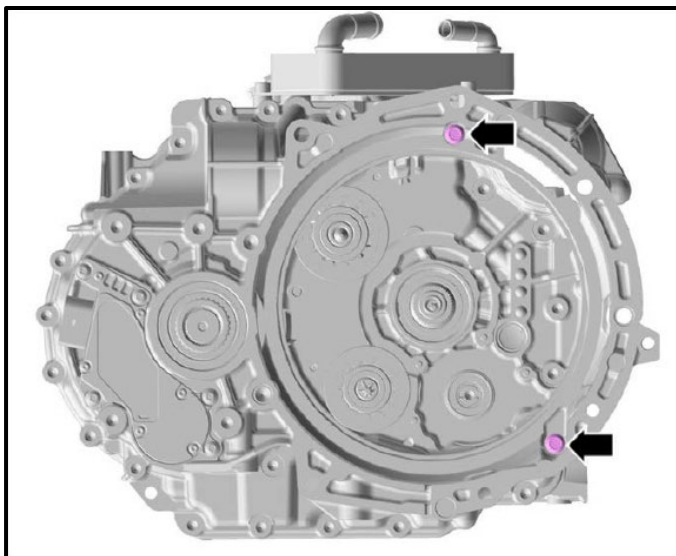

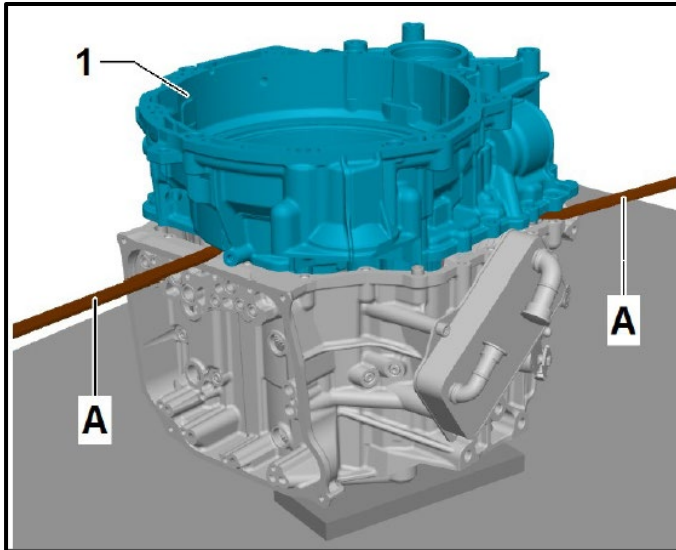

**Release sealant bead:**

- Carefully release sealant bead between housing sections by applying minimal force using pry bars <A>.

**TIP**

If the housings are not separating, make sure all of the oil guide tubes are removed.

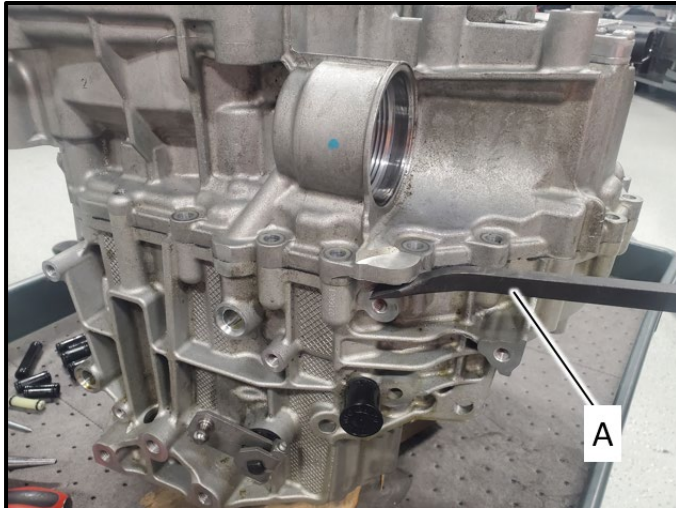

**NOTE**

Proper positioning of pry bar <A> shown.

**CAUTION**

**Risk of irreparable damage to gearbox housing.**

Use extreme care when releasing the sealant bead and do not use excessive force.

Pay close attention to surfaces being pried against so that damage does not occur.

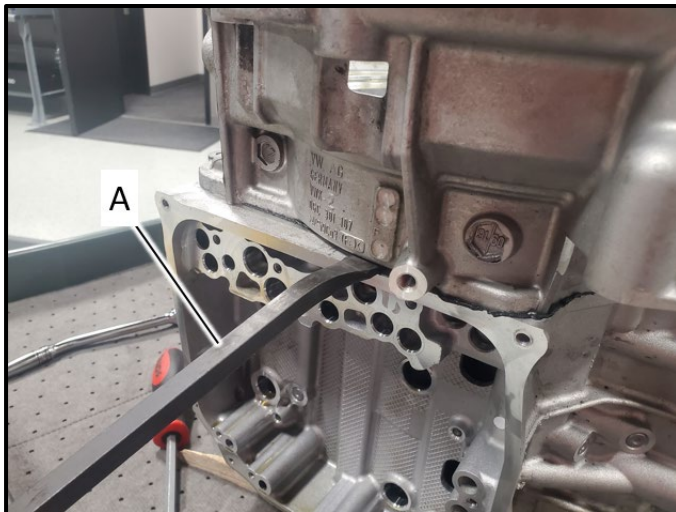

**NOTE**

Proper positioning of pry bar <A> shown.

**CAUTION**

**Risk of irreparable damage to gearbox housing.**

Use extreme care when releasing the sealant bead and do not use excessive force.

Pay close attention to surfaces being pried against so that damage does not occur.

Pay particular attention to the transmission oil pan sealing surface. The surface must not be compromised.

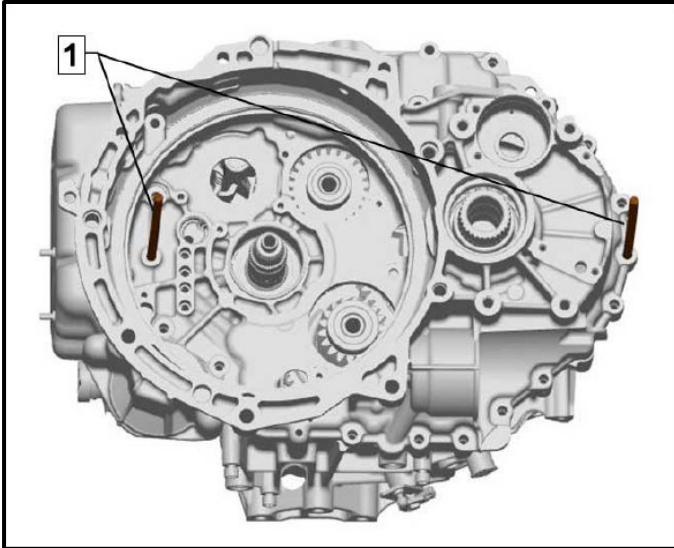

**Install guide pins:**

- Screw guide pins -T40288- <1> into gearbox housing on opposite sides, as shown.



- To aid in re-assembly, mark the position of both guide pins on gearbox housing with a felt-tip pen.

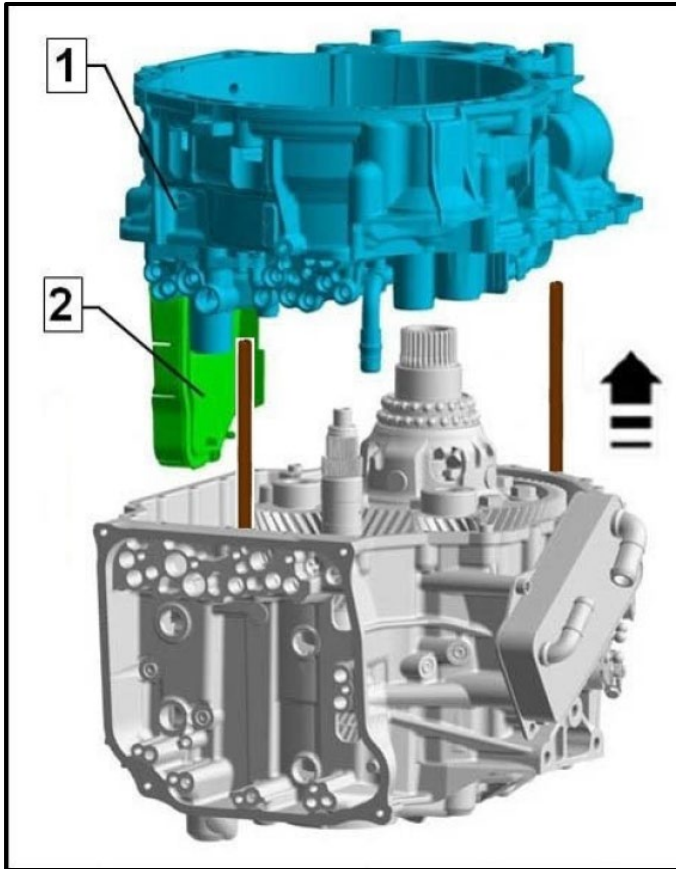

**Remove clutch housing:**

- Lift clutch housing <1> off vertically along guide pins.
- Place clutch housing <1> down safely on a suitable workbench with intake filter <2> facing upwards.

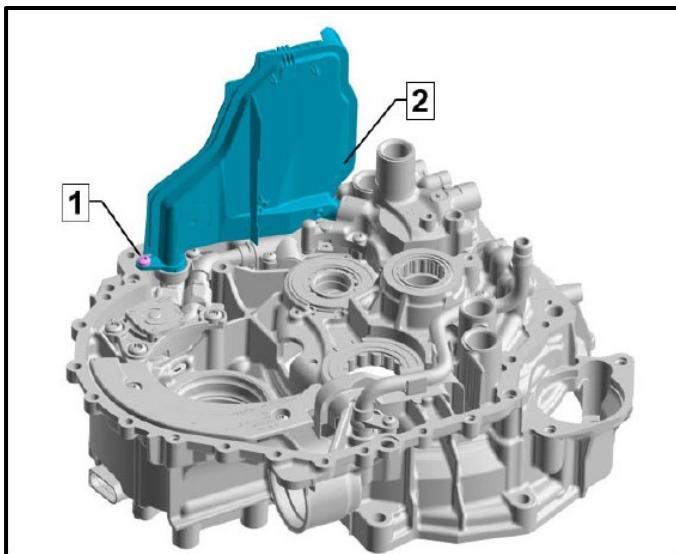

**Remove filter:**

- Remove bolt <1> and remove intake filter <2>.

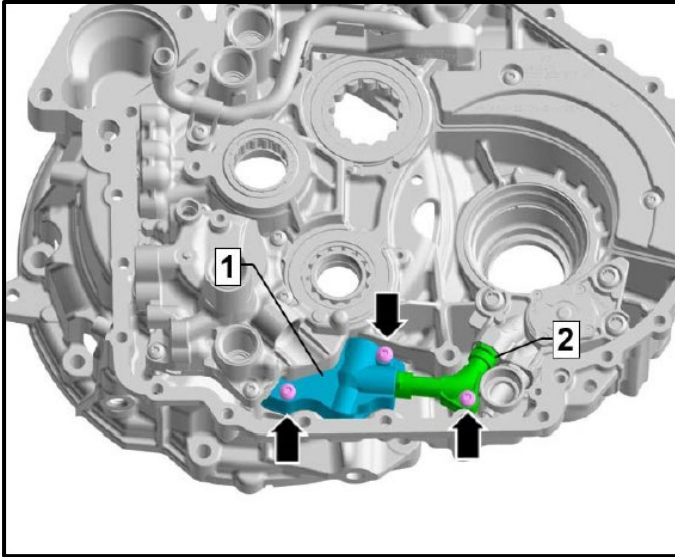

#### Remove changeover valve bolts:

- The changeover valve and pipe are not removed.
- Remove bolts <arrows> for changeover valve <1> and oil pipe <2>.
- Note the length of the removed bolts. There are two different length bolts.

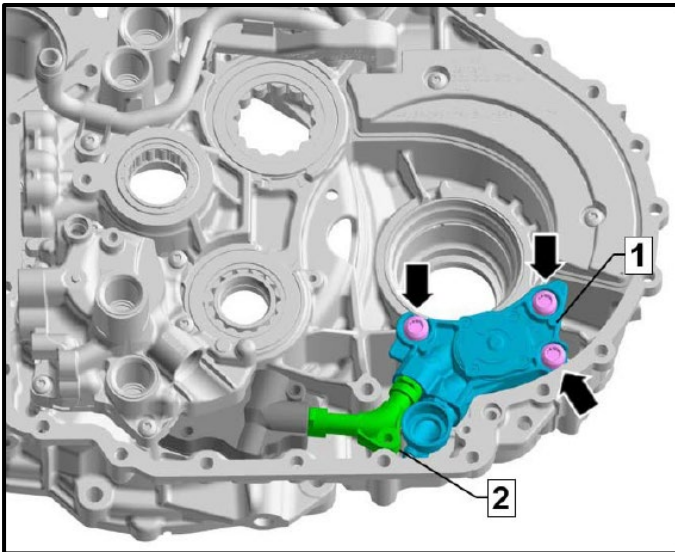

#### Remove auxiliary hydraulic pump:

- Remove bolts <arrows>.
- Carefully detach auxiliary hydraulic pump <1> upwards and pull it out of oil pipe <2>.



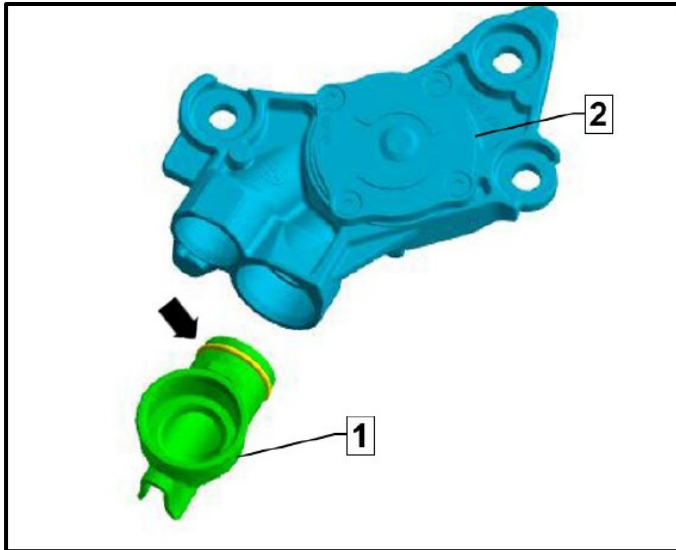

**Replacing auxiliary hydraulic pump:**

- Fit a new oil pipe <1> from the repair kit to the new auxiliary hydraulic pump <2>.
- Coat the o-ring on the oil pipe with clean oil.

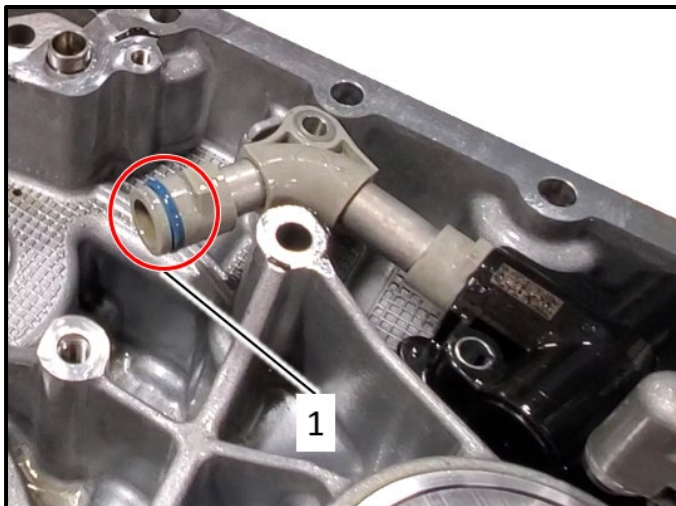

- Install new O-ring <1> from the repair kit on the changeover valve oil pipe.

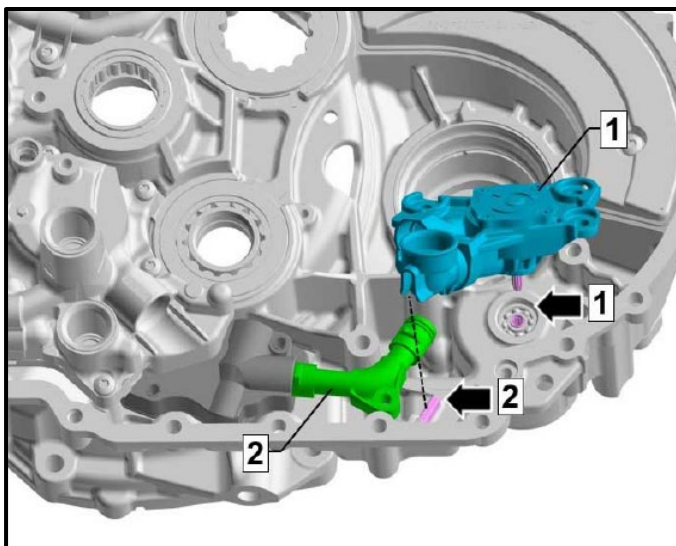

**Install auxiliary hydraulic pump:**

- Install new auxiliary hydraulic pump with oil pipe from the repair kit in the reverse order of removal.
- When installing, ensure that the shaft matches up with the splines in the housing <arrow 1> and the oil pipe guide is fitted on the rib <arrow 2> on the housing.

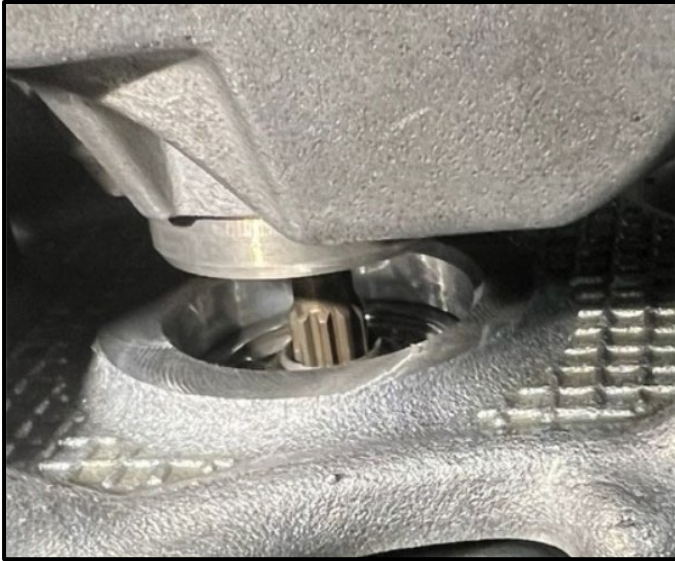

**NOTE**

Detail of auxiliary hydraulic pump shaft splines shown.

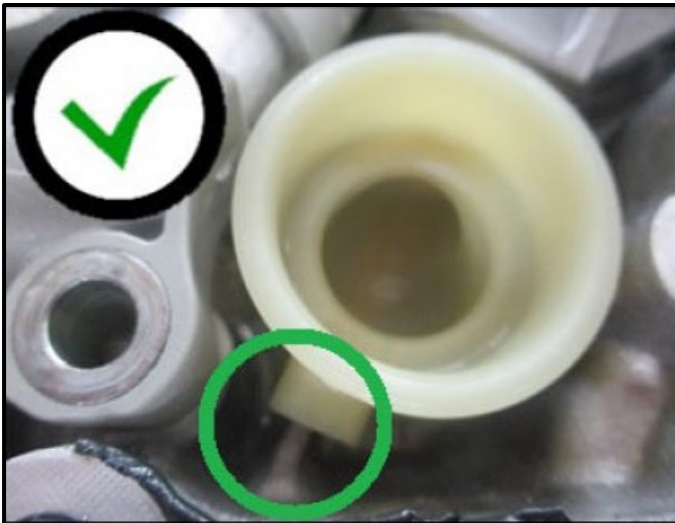

**Verify oil pipe installation:**

- Verify that the oil pipe is installed correctly as shown.
- The recess on the oil pipe must fit correctly over the rib on the housing.

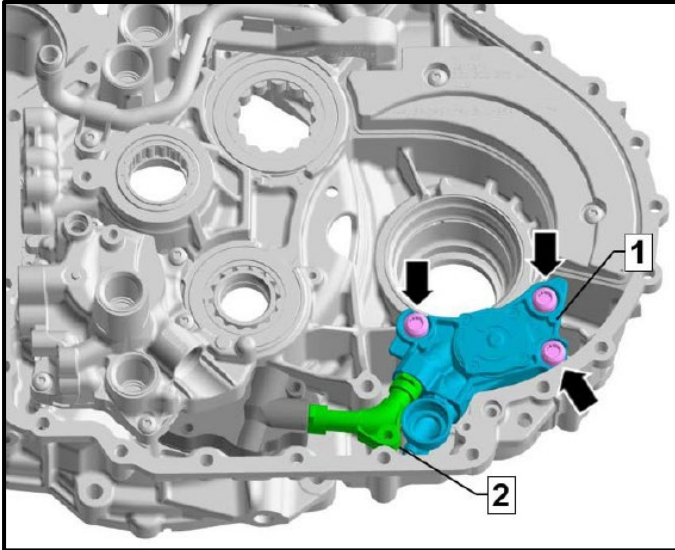

#### Install new auxiliary hydraulic pump bolts:

- Install new bolts <arrows> from the repair kit and torque to 20 Nm + 90°.

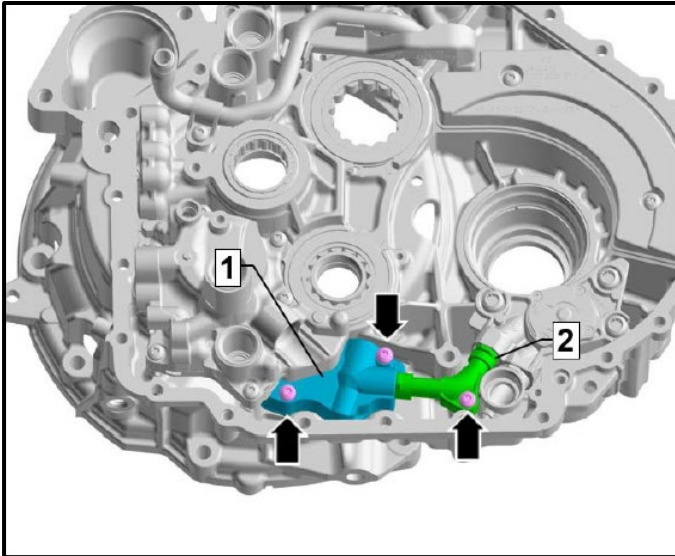

#### Install new bolts for changeover valve and oil pipe:

- Install new bolts <arrows> from the repair kit and torque to 8 Nm + 90°.



#### NOTE

Please note that the bolt for the oil pipe is shorter than the two bolts for the changeover valve.

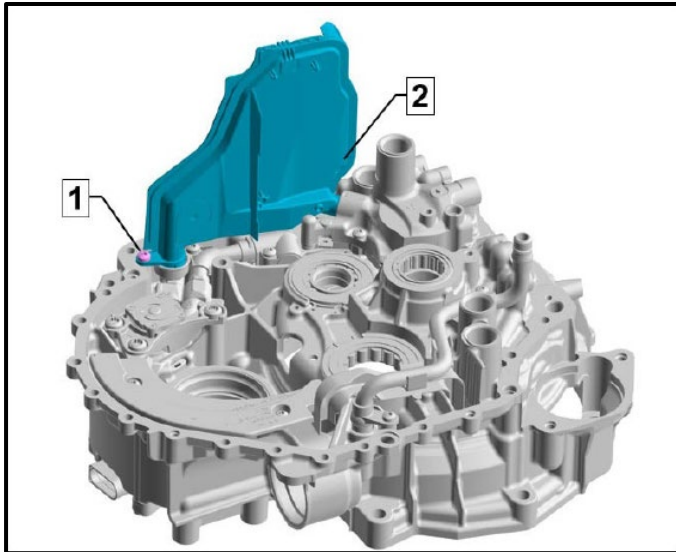

**Install new filter and bolt:**

- Install new filter <2> from the repair kit and torque new bolt from the repair kit <1> to 8 Nm + 90°.

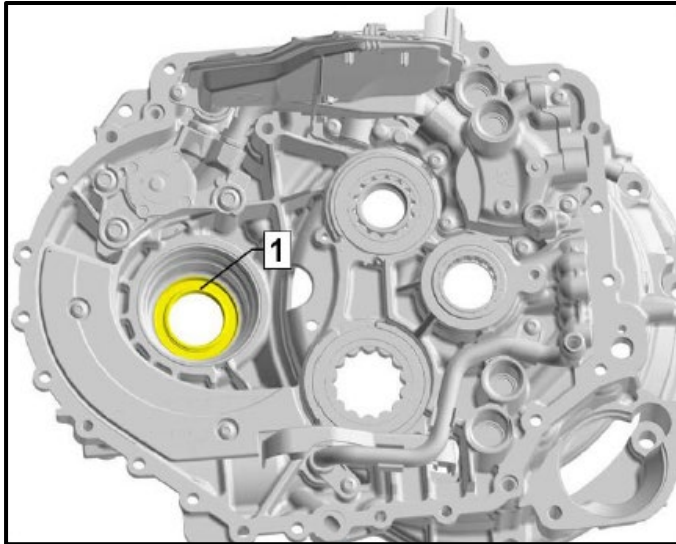

**Remove oil seal:**

- Remove oil seal <1> from clutch housing.

**Prepare gearbox housing for assembly:**

- Clean the sealing surfaces on both housings thoroughly.
- Allow cleaner to dry completely.
- Ensure there is no dirt or sealant residue left inside the gearbox.
- Ensure all oil passages are free of dirt and residue.

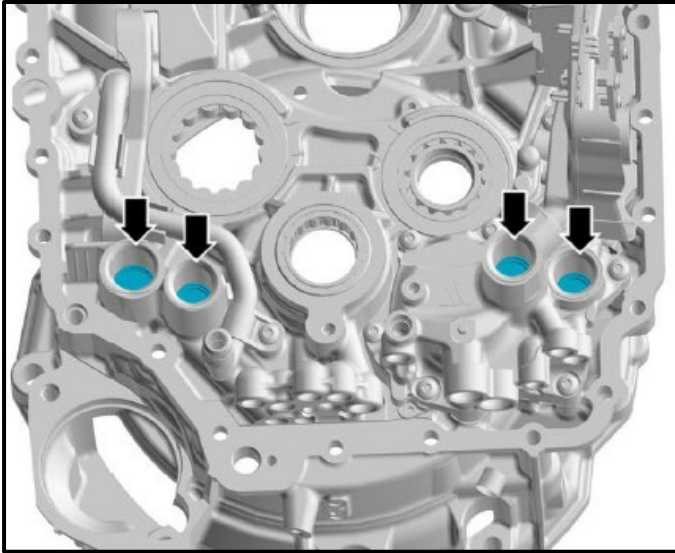

- Carefully press pistons for selector rods <arrows> into end position using a suitable tool (socket, for example) if necessary.

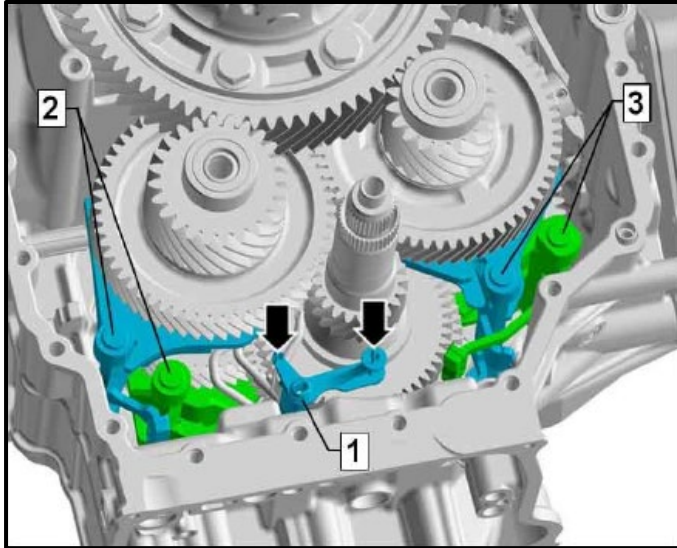

- Move shift forks <2> and <3> into neutral position.

**NOTE**

The shift forks are in the neutral position when the radius cut out on the shift forks are clearly visible in the center of the windows of the gearbox housing.

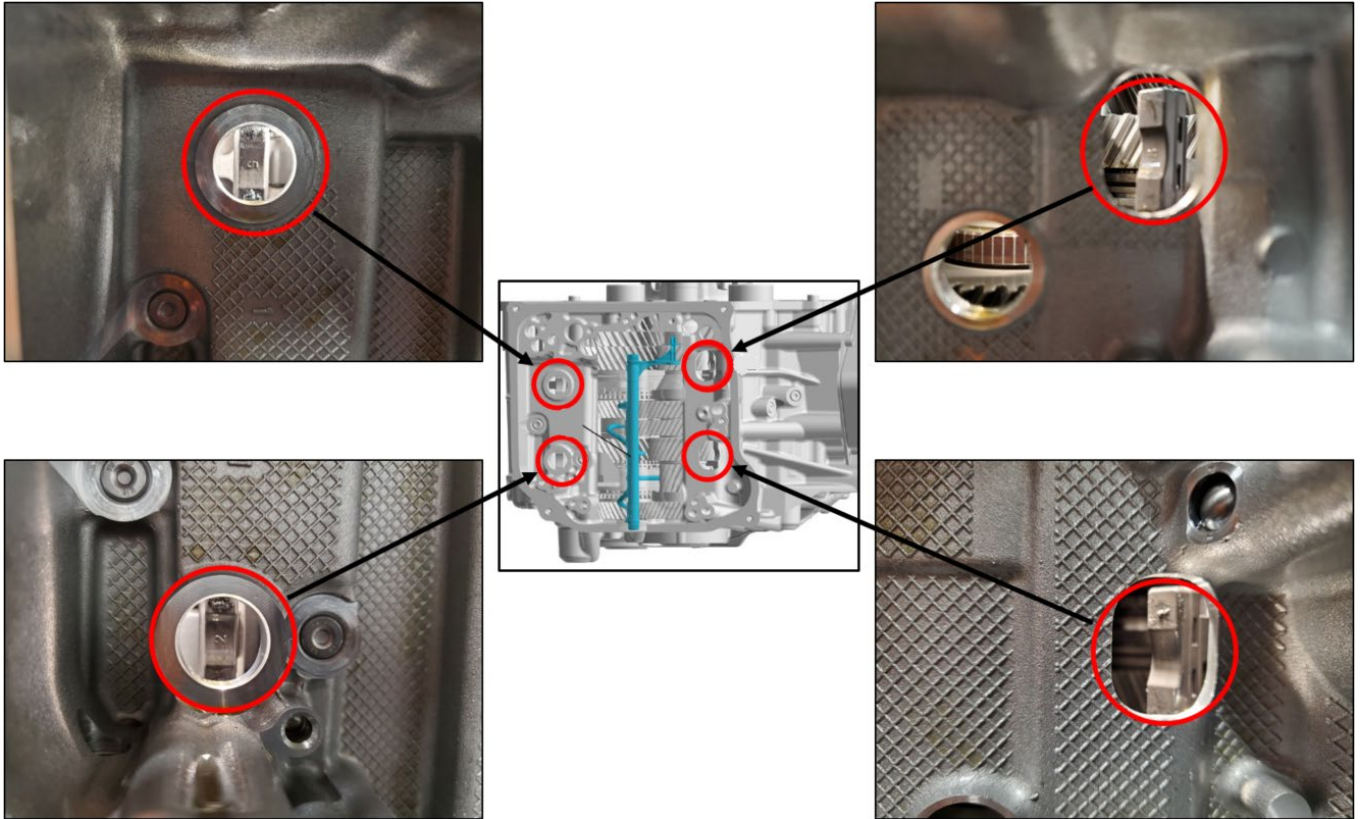

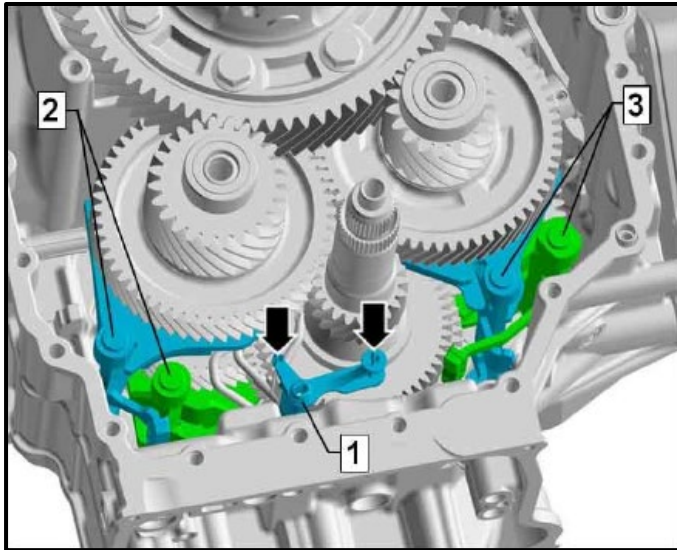

- Align injection pipe <1> correctly in housing; guides <arrows> must align precisely with clutch housing when fitted.
- Move selector forks <2> and <3> into neutral position.

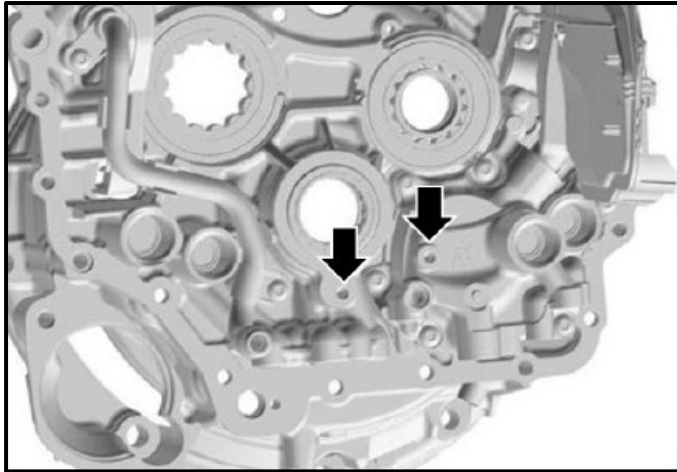

- The two guides of the injection pipe must be inserted precisely into the corresponding holes <arrows> in the clutch housing during assembly.
- In the event of an incorrect alignment, it will not be possible to install the clutch housing.

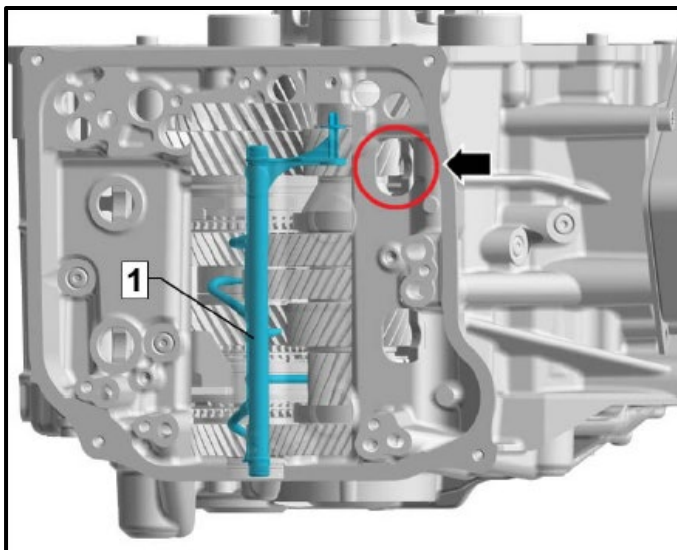

- When fitting the housing sections together, you can reach through the opening <arrow> with your finger to adjust the position of the injector pipe <1> slightly.

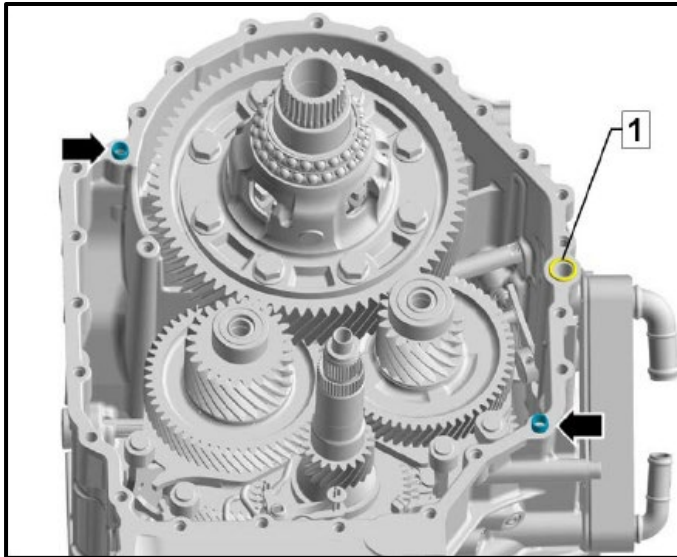

- Install new O-ring <1> from the repair kit.

**NOTE**

To aid in assembly, the O-ring can be held in place using no more than 1 gram of Vaseline.

- Check that dowel sleeves <arrows> are not damaged and are seated correctly.

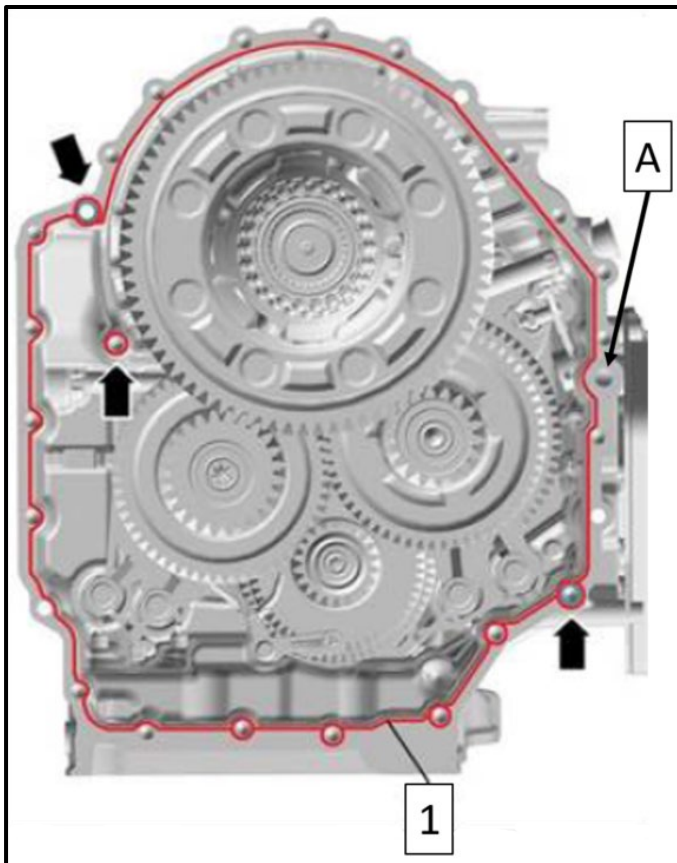

**Apply sealant:**

- Apply a bead of sealant <1> to the gearbox housing as shown.
- Ensure sealant is applied completely around any openings as shown in the illustration.
- Pay close attention to the dowel sleeves and "turret" <arrows>. Ensure sealant is applied completely around those openings.

**NOTE**

The O-ring is installed at area <A>. Note that sealant is only applied on the inside edge of the housing in the area of the O-ring. Do not allow sealant to enter the oil opening.



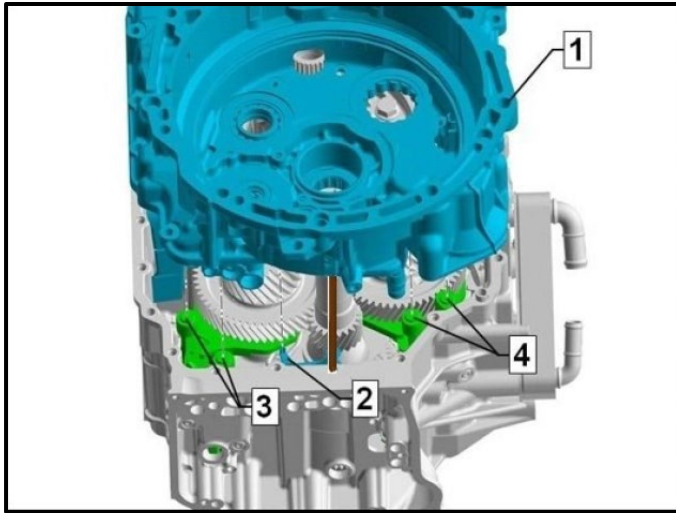

### Reassemble gearbox housing:

- Reference the previously made marks and reinstall guide pins -T40288- into the gearbox housing (if the guide pins were previously removed).
- With the assistance of a second technician, carefully install clutch housing <1> on roller bearings in gearbox housing.
- When installing, pay attention to injection pipe <2> and selector forks <3> and <4>.
- With minimal corrections and shaking lightly, fit housing sections together until air gap between housings is 0 mm.
- If an air gap of 0 mm is not attained, lift clutch housing <1> again and check positions of injection pipe <2> and selector forks <3> and <4>, and correct if necessary.
- Again with minimal corrections and shaking lightly, fit housing sections together until air gap is 0 mm.
- Unscrew guide pins -T40288-.
- Screw in new bolts <1 to 22> from repair kit for housing hand tight on clutch end.

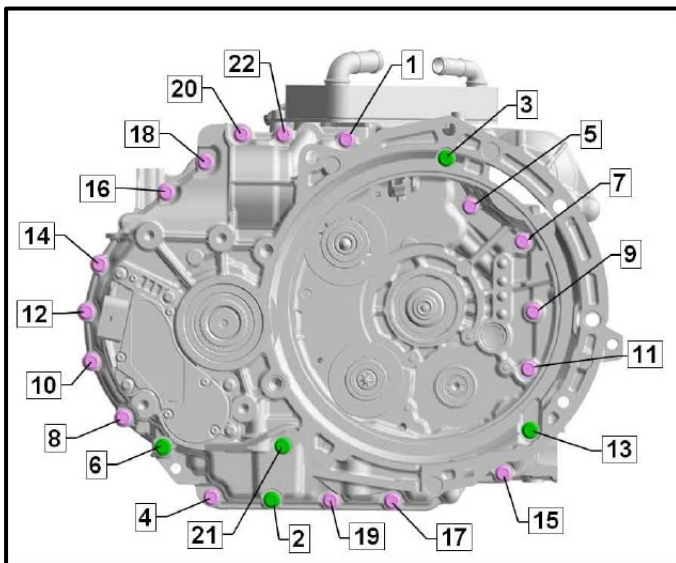

### NOTE

Note the different bolt lengths:

- Pink bolts = M8x38
  - Green bolts = M8x75
- After all bolts are hand tight, torque the bolts as follows in sequence <1 to 22>:
    - 1<sup>st</sup> stage = 20 Nm.
    - 2<sup>nd</sup> stage = 90°
  - The gearbox can now be moved to the engine stand for final assembly.

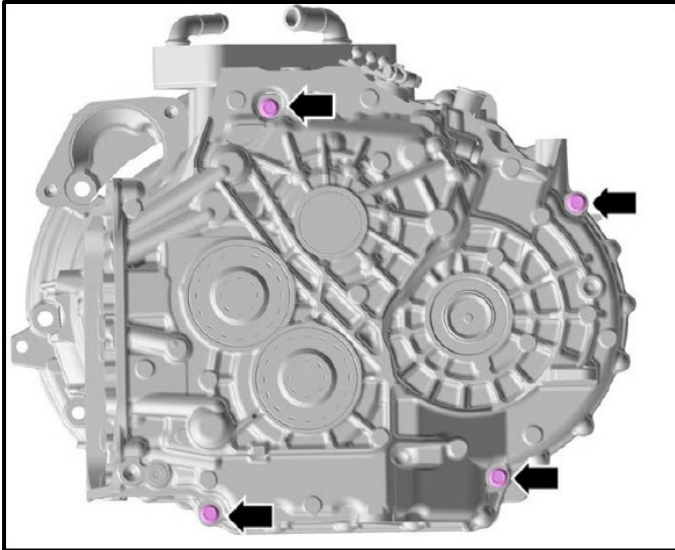

- Install new bolts <arrows> from the repair kit and torque to 20 Nm + 90°.

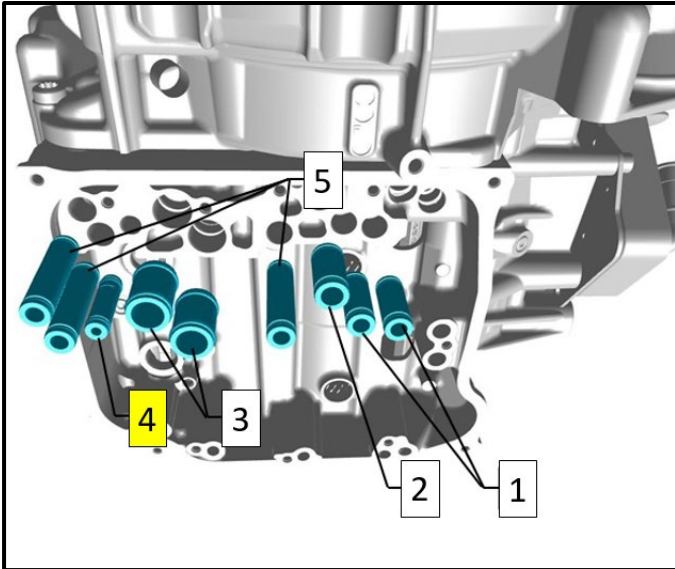

**Install new oil guide tubes:**

- Lubricate new oil guide tubes lightly with gearbox oil before installing.
- Install new oil guide tubes <1 to 5> from the repair kit.

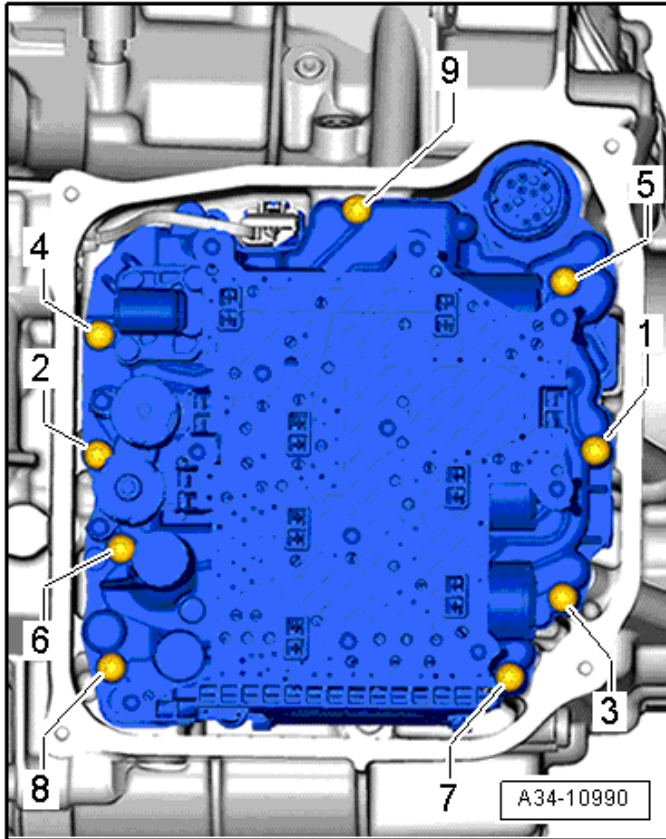

#### Reinstall Mechatronic:

- Installation is the reverse order of removal.
- Use new bolts from the repair kit.
- Tighten bolts as follows in sequence <1 to 9>:
  - 1<sup>st</sup> stage = by hand
  - 2<sup>nd</sup> stage = 8 Nm
  - 3<sup>rd</sup> stage = 45°

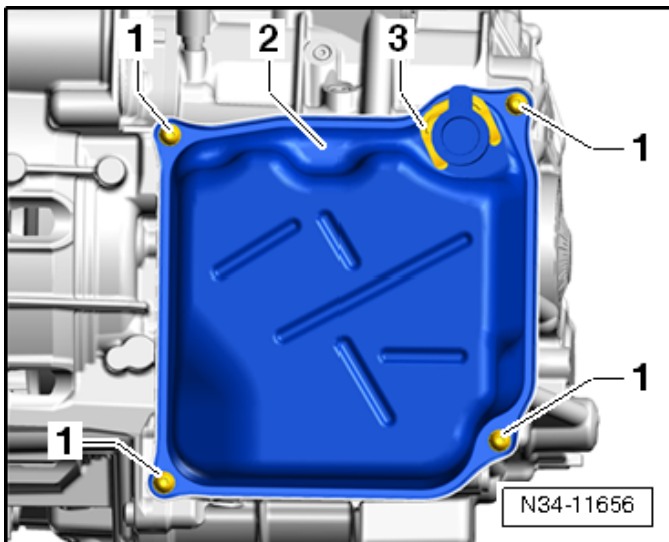

#### Install new cover:

- Clean the sealing surface on the gearbox housing of oil and grease.
- Coat the O-ring with new gear oil.
- Install new cover from repair kit in the reverse order of removal.
- Tighten new bolts from repair kit diagonally in multiple steps and torque to 8 Nm + 60°.
- Install new clamp <3>.

Part Number	Part Description
0BH-325-147	Retaining clamp

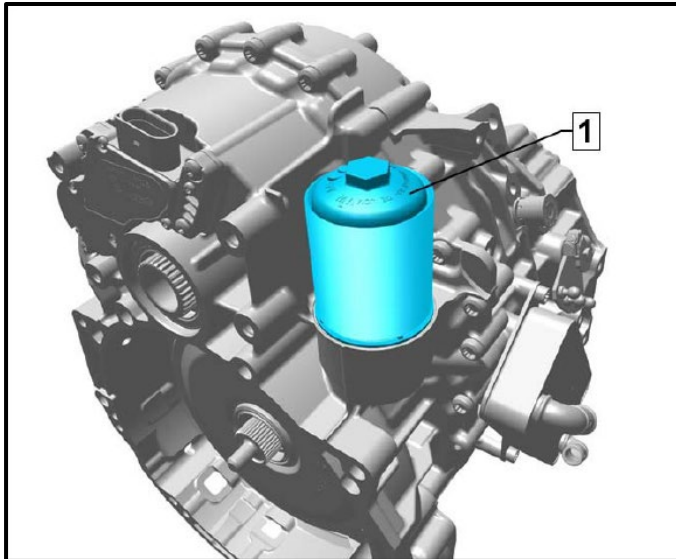

#### Install new gear oil filter from repair kit:

- Coat O-ring with new gear oil.
- Install new gear oil filter and housing and torque to 50 Nm.

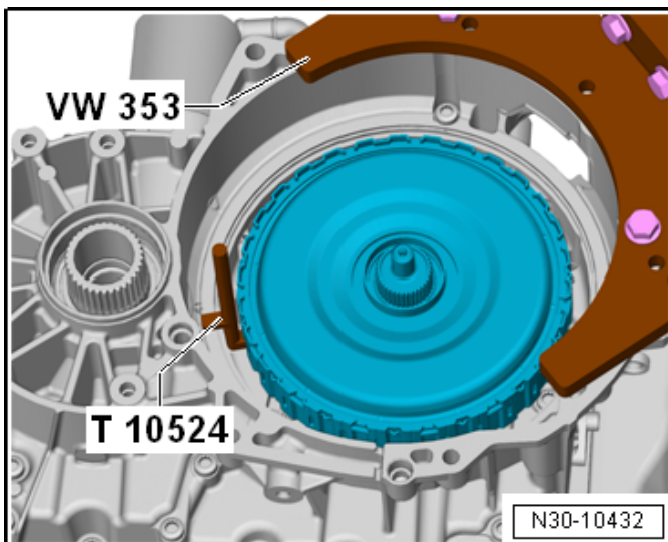

#### Install dual clutch:

- See ELSA Repair Manual: *Repair manual > Drivetrain > 7-Speed DSG Transmission OGC > 30 Clutch > Clutch > Dual Clutch, Installing*
- Use new circlip from repair kit.

#### ! NOTE

The dual clutch does not need to be re-adjusted; the retaining ring can be re-used, contrary to the information in the Repair Manual.



#### Install new oil seals:

- Reference ELSA Repair Manual: *Repair manual > Drivetrain > 7-Speed DSG Transmission OGC > 39 Final Drive, Differential > Seals*

#### NOTE

The repair kit can be used for vehicles with front-wheel drive or all-wheel drive and includes three seals; please make sure that there is always one oil seal left over.

AWD vehicles:

- Left seal p/n = 0BH-409-400-E
- Right seal p/n = 02Q-409-189-A

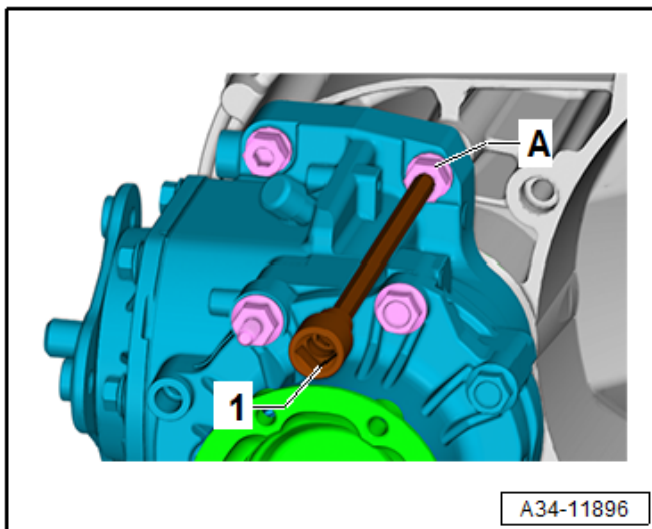
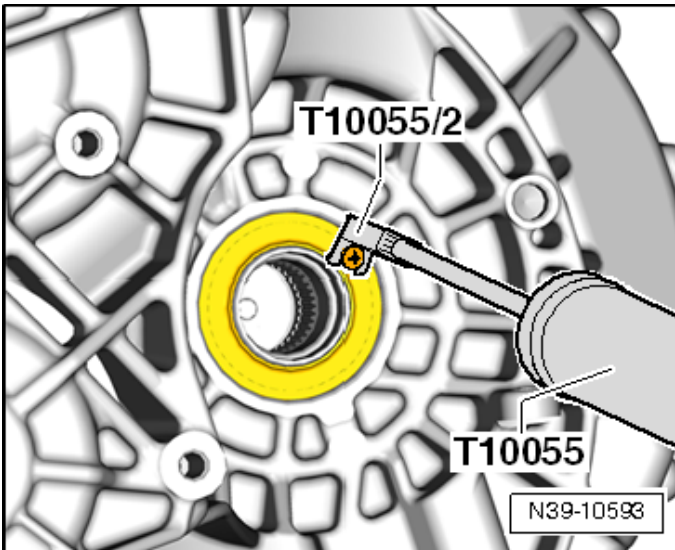

#### Reinstall bevel box:

- See ELSA Repair Manual: *Repair manual > Drivetrain > 7-Speed Dual Clutch Transmission OGC > 34 Controls, Housing > Bevel Box > Bevel Box, Installing*
- Use new bolts.

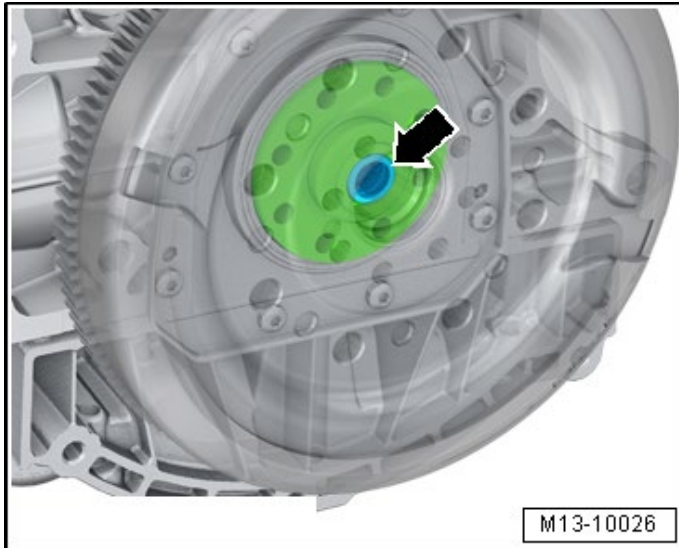

#### Replace crankshaft needle bearing:

- Reference ETKA for the correct needle bearing part number.
- See ELSA Repair Manual: *Repair manual > Engine > 4-Cylinder Direct Injection (2.0L, 4V, Turbocharger, Chain Drive, Generation III) - R Models > 13 Crankshaft, Cylinder Block > Crankshaft > Crankshaft Needle Bearing, Replacing*

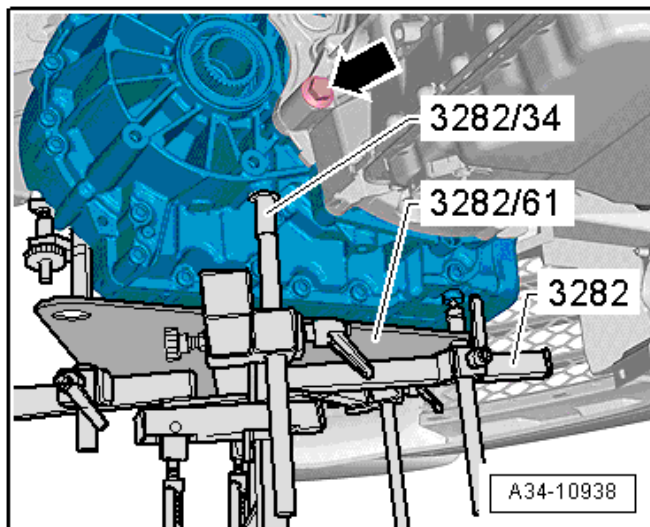

#### Reinstall transmission:

- See ELSA Repair Manual: *Repair manual > Drivetrain > 7-Speed DSG Transmission 0GC > 34 Controls, Housing > Transmission, Removing and Installing > Transmission, Installing*

## Clear TCM DTC memory and perform basic settings:

- Connect diagnostic tester to the vehicle.
- Perform a full vehicle scan using Diagnosis.
- Switch to Self-diagnosis.
- Select “Basic Setting” for 0002 – Transmission electronics.

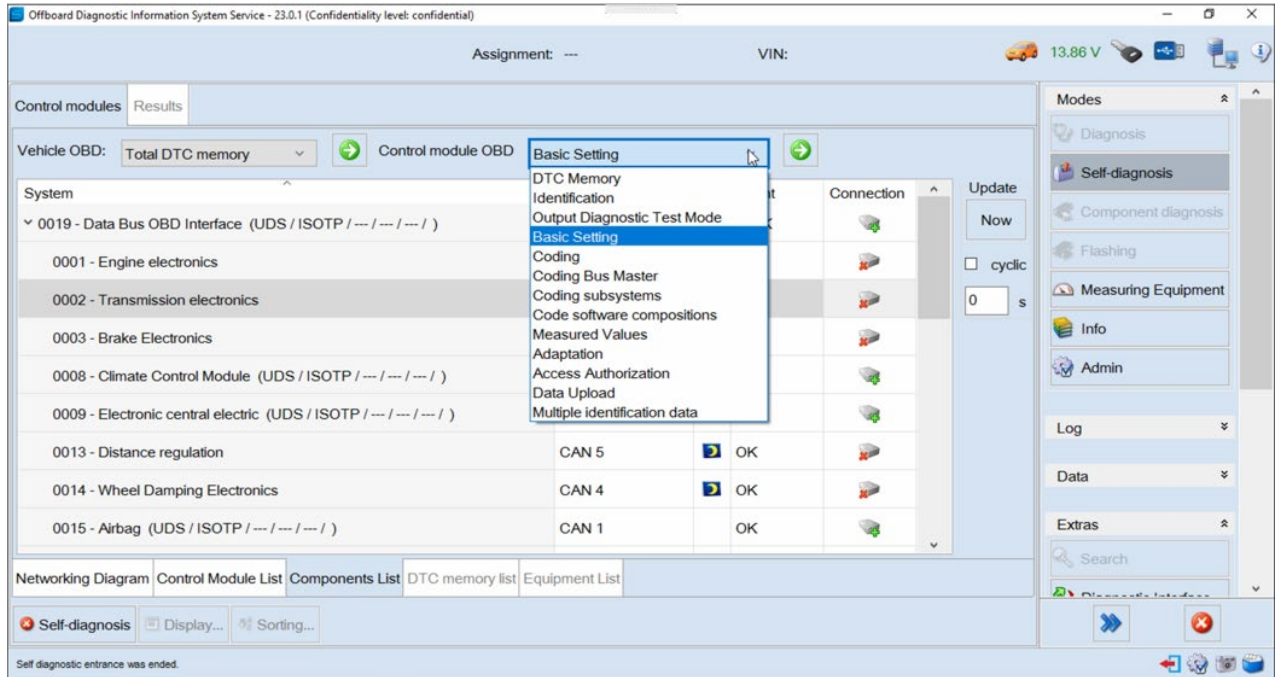

The screenshot displays the 'Offboard Diagnostic Information System Service - 23.0.1 (Confidentiality level: confidential)' interface. The main window shows a list of control modules under the 'System' tab. The '0002 - Transmission electronics' module is selected, and a context menu is open over it, with 'Basic Setting' highlighted. The menu options include: DTC Memory, Identification, Output Diagnostic Test Mode, Basic Setting, Coding, Coding Bus Master, Coding subsystems, Code software compositions, Measured Values, Adaptation, Access Authorization, Data Upload, and Multiple identification data. The interface also shows a 'Control module OBD' section with a 'Basic Setting' button and a 'Connection' column with status indicators. A 'Modes' sidebar on the right includes options like 'Diagnosis', 'Self-diagnosis', 'Component diagnosis', 'Flashing', 'Measuring Equipment', 'Info', and 'Admin'. The bottom status bar indicates 'Self diagnostic entrance was ended'.

System	Control module OBD	Connection	Status
0019 - Data Bus OBD Interface (UDS / ISOTP / --- / --- / --- / )			
0001 - Engine electronics			
0002 - Transmission electronics			
0003 - Brake Electronics			
0008 - Climate Control Module (UDS / ISOTP / --- / --- / --- / )			
0009 - Electronic central electric (UDS / ISOTP / --- / --- / --- / )			
0013 - Distance regulation	CAN 5		OK
0014 - Wheel Damping Electronics	CAN 4		OK
0015 - Airbag (UDS / ISOTP / --- / --- / --- / )	CAN 1		OK

- Move basic setting, “[VO]\_Clear\_cover\_plate\_failure\_of\_auxilliary\_fluid\_pump” to the selection box.
  - The basic setting can be moved by double clicking the basic setting, or by clicking on arrow <1>.

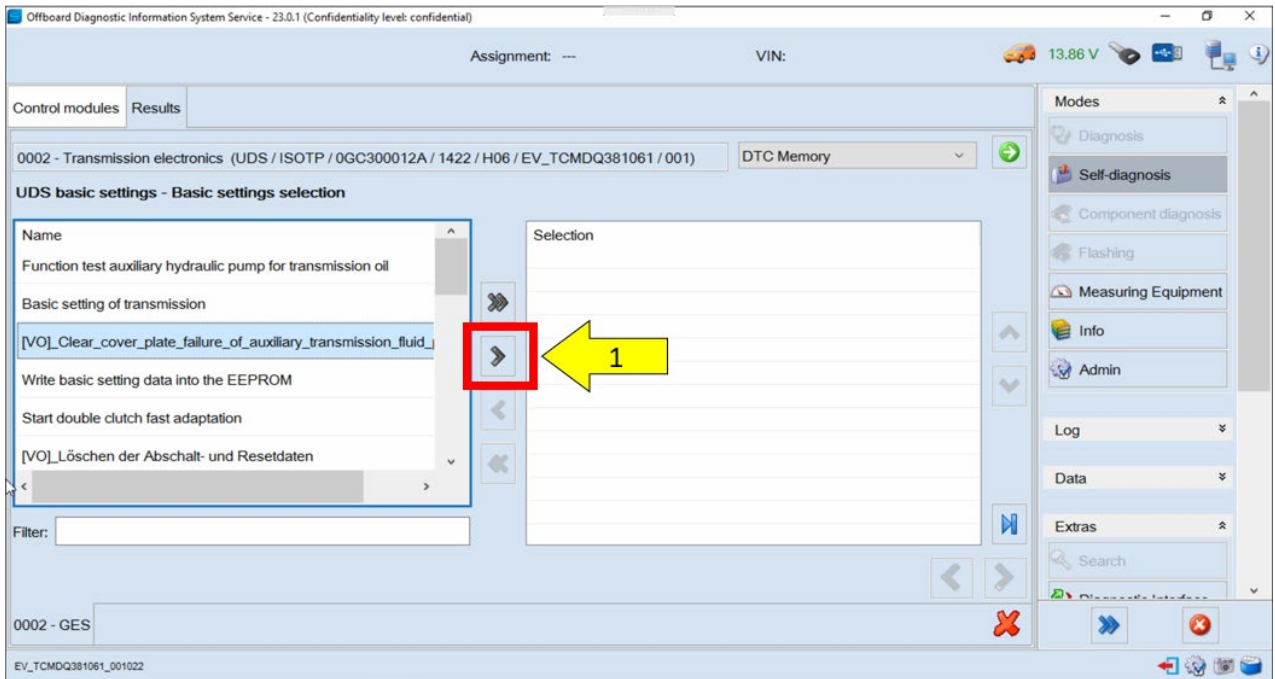

- Once the basic setting is in the selection box, continue by clicking the blue forward arrow <1>.

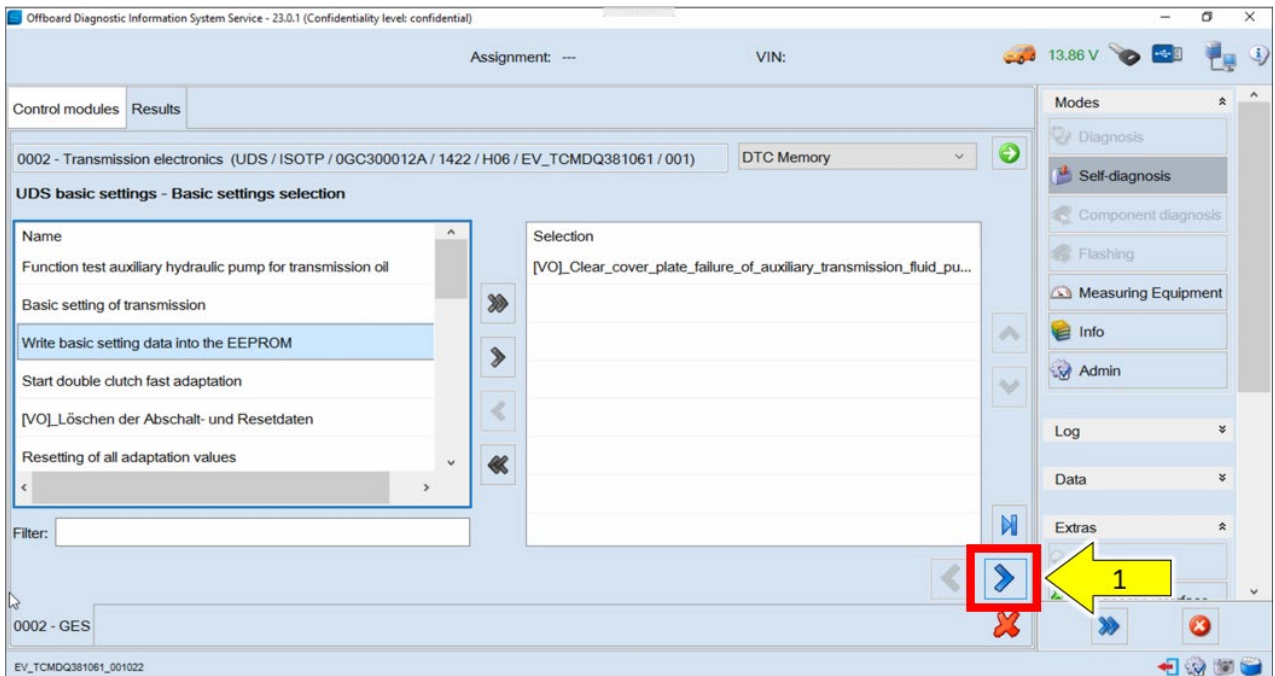



- Click in the empty “Value” box and select “not available” <1>.
- Continue by clicking the blue forward arrow <2>.

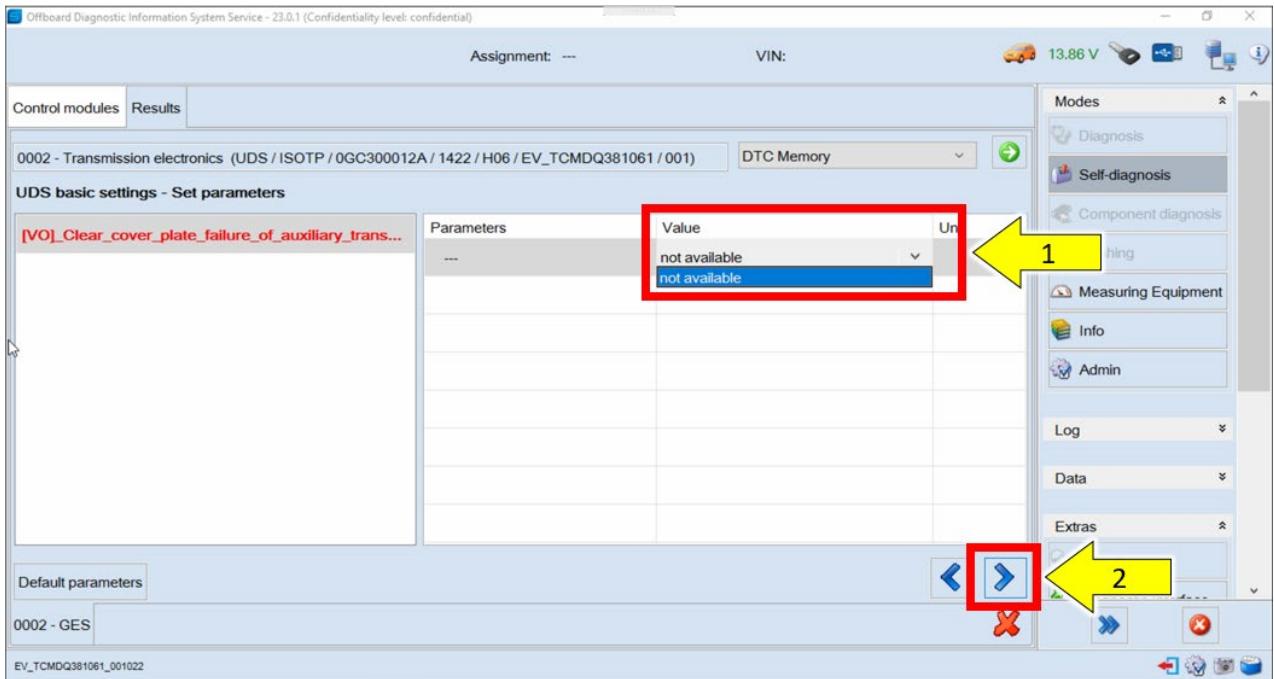

- All measured values will need to be moved to the selection box, and measured value “[VO]\_Auxilliary\_transmission\_fluid\_pump\_cover\_plate\_diags\_number” will need to be listed first.
  - Type “fluid” in the filter box and move measured value, “[VO]\_Auxilliary\_transmission\_fluid\_pump\_cover\_plate\_diags\_number” to the selection box.
  - Then delete “fluid” from the filter box and move all of the remaining measured values to the selection box.
  - Once all measured values are in the selection box, click on the blue forward arrow <1>.

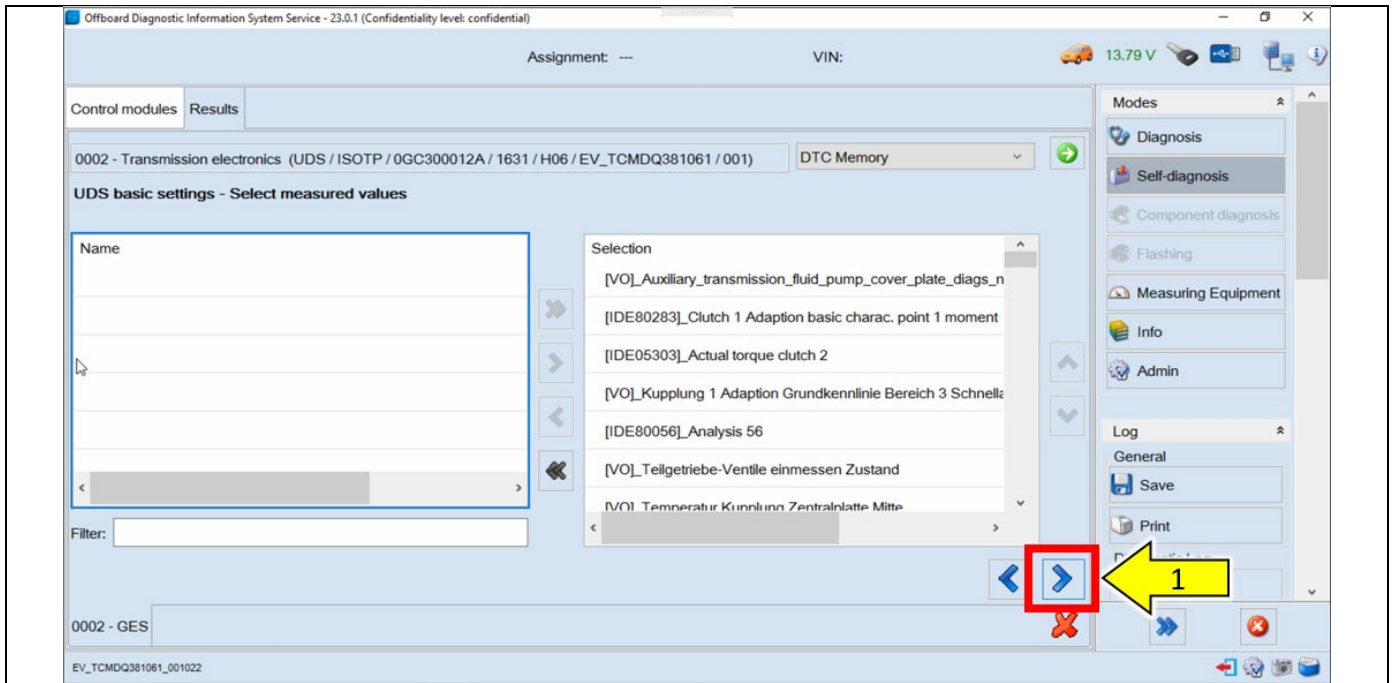

- Click “Start” <1> to begin the basic setting routine.
- Once the basic setting is complete, the event memory entry will then be set to “intermittent” and can be erased.

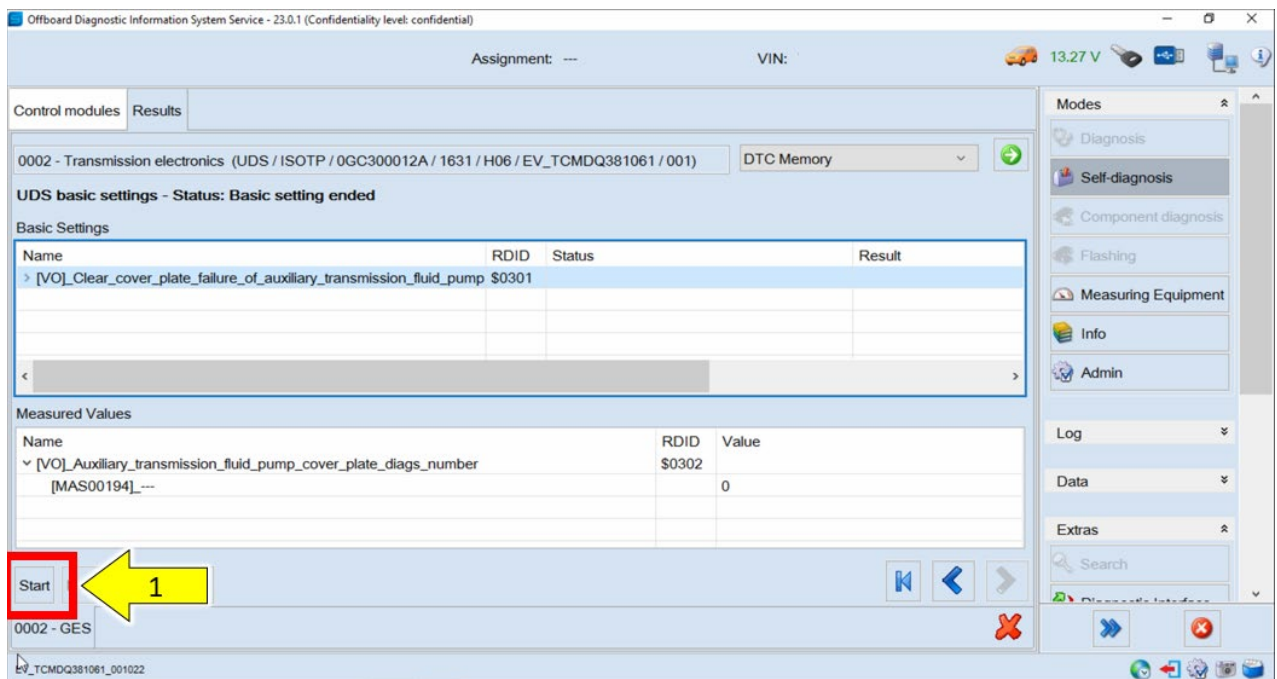

- Once the fault is erased, switch to Operating Mode “Diagnosis.”
- Select Guided Functions test plan, “02 – Basic Setting” <1>.
- Follow the on-screen prompts.

Offboard Diagnostic Information System Service - 23.0.1 (Confidentiality level: confidential)

Assignment: --- VIN: 13.86 V

Control modules Orders DISS TSB Test plan Procedure Sp

Control module list (1 entries)

Address	Event	Name
0001	0	Engine electronics (01 - Engine Electronics)
0002	0	Transmission electronics (02 - Transmission Electronics)
0022	0	All-wheel drive electronics (22 - All Wheel Drive Electronics)
0042	0	Driver's door electronics (42 - Driver's Door Electronics)
0052	0	Passenger's door electronics (52 - Passenger's Door Electronics)
0003	0	Brake Electronics (03 - Brake Electronics)
0013	0	Distance regulation (13 - Distance Regulation)
0014	0	Wheel Damping Electronics (14 - Wheel Dampening Electronics) (8V0907376G 0082 DAEMPFUNGS-SG)
0044	0	Power Steering (44 - Power Steering) (3Q0909144K 5072 EPS_MQB_ZFLS)
0015	0	Airbag (15 - Airbag) (5Q0959655J 0830 AirbagVW20)

Guided Functions

Transmission electronics

- 0002 - SVM - Check control module configuration
- 02 - Basic Setting**
- 02 - Check/erase DTC memory
- 02 - Code control module
- 02 - Identification Services
- 02 - Read Measuring Values
- 02 - Replace Mechatronic (control module)

Run Cancel

Networking Diagram Control Module List Components List DTC memory list Equipment List

Diagnosis Display... Sorting...

Modes

- Diagnosis
- Self-diagnosis
- Component diagnosis
- Flashing
- Measuring Equipment
- Info
- Admin

Log Data Extras Search

The diagnostic entrance was ended.

- Perform the following basic settings in sequence and follow the on-screen prompts:
  - Transmission basic setting
  - Adaptation drive of transmission

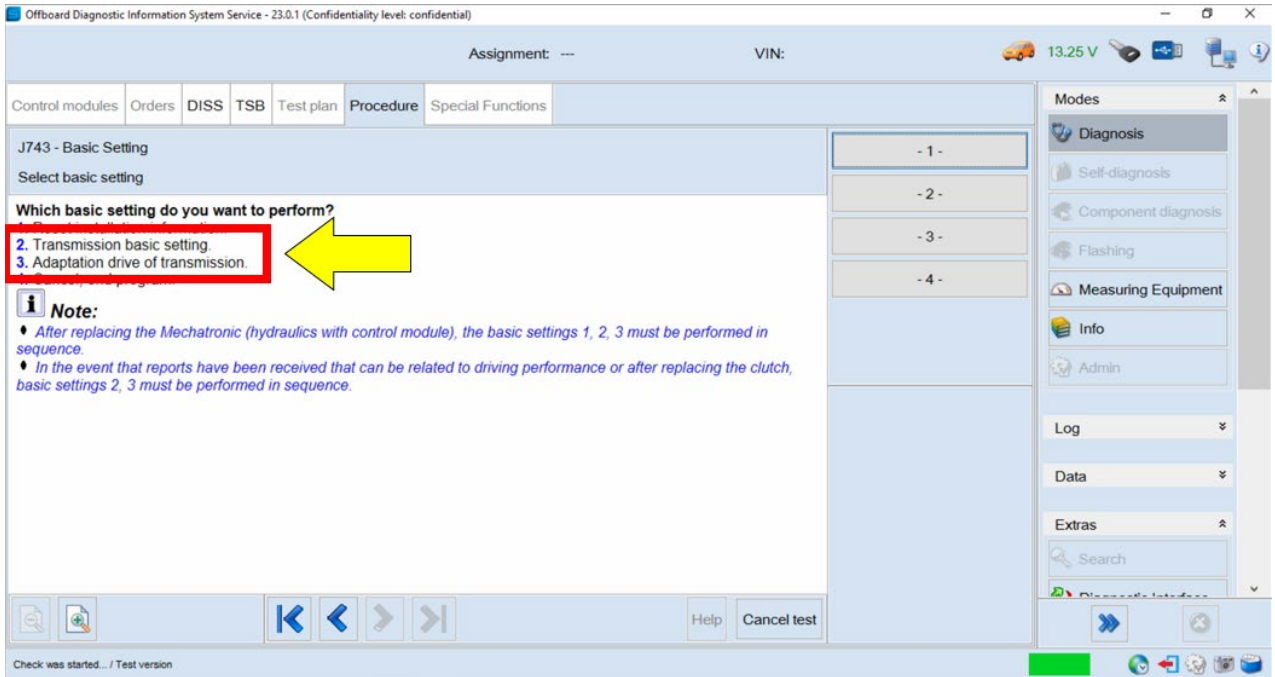

- Pay close attention to the information found in the Function test guides before performing the “Adaptation drive of transmission” basic setting.

