



STAR ONLINE PUBLICATION



Case Number: S2323000035 Rev. A

Release Date: June 2023

Symptom/Vehicle Issue: Installing Rear License Plate, License Plate Not Completely Visible as Expected

Technician Observation: The license plate does not display in full as expected.

Discussion: License plate installation for North America market vehicles requires a license plate bracket. Rear plate bracket 68607295AA and 3 self-tapping screws 68113529AA should be in the vehicle upon delivery from transport. See Pg 1 and 2.

Example Dodge Hornet:



Plate Installed Incorrectly - Too High

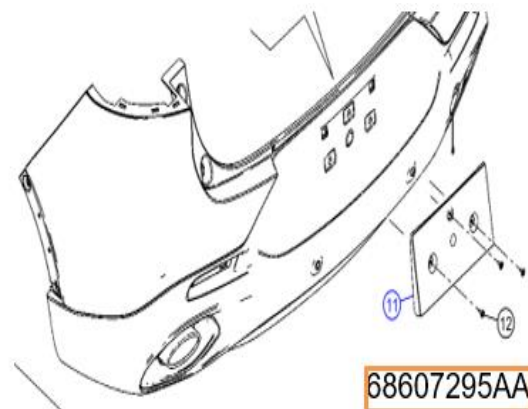

Plate Bracket and Screws

Pg 1

This document does not authorize warranty repairs. This communication documents a record of past experiences. STAR Online does not provide any conclusions about what is wrong with the vehicle. Rather, it captures all previous cases known that appear to be similar or related to the vehicle symptom / condition. You are the expert, and you are responsible for deciding on the appropriate course of action.

Contact STAR Center, or your Technical Assistance Center Via TechCONNECT or eCONTACT ticket if no solution is found



STAR ONLINE PUBLICATION

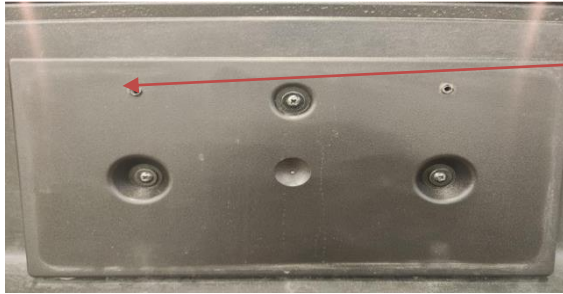

Using the license plate as a guide, hold the plate centered on the bracket. Automatic spring loaded center punch mark the screw locations first. Pilot drill the bracket. Then install the license plate with self-tapping screws.

Pg 2

This document does not authorize warranty repairs. This communication documents a record of past experiences. STAR Online does not provide any conclusions about what is wrong with the vehicle. Rather, it captures all previous cases known that appear to be similar or related to the vehicle symptom / condition. You are the expert, and you are responsible for deciding on the appropriate course of action.

Contact STAR Center, or your Technical Assistance Center Via TechCONNECT or eCONTACT ticket if no solution is found