



# Technical Service Bulletin

---

## 92 Washer solvent level warning is on

92 23 36 2038151/15 July 17, 2023. Supersedes Technical Service Bulletin Group 92 number 23-35 dated May 22, 2023 for reasons listed below.

Model(s)	Year	VIN Range	Vehicle-Specific Equipment
All Audi Vehicles	2012 – 2021	All	Not Applicable

## Condition

REVISION HISTORY		
Revision	Date	Purpose
15	-	Revised header (Remove MY 2022 - 2024) Revised Service (Remove Q4 e-tron and Audi e-tron GT) Revised <i>Warranty</i> (Remove Q4 e-tron and Audi e-tron GT, remove GFF allowance and road test allowance)
14	05/22/2023	Revised <i>Warranty</i> (Updated Labor Operations)
13	02/07/2023	Revised <i>Warranty</i> (Updated Labor Operations)

### Customer states:

- The washer solvent level warning is on in the driver information system (DIS), but the washer solvent level is correct.

### Workshop findings:

- There is no functional restriction in the windshield washer system.

## Technical Background

The sensitivity of the washer solvent level sensor (G33) can be affected by the type, concentration, and the presence of additives in the washer solvent currently in the tank. The operation of the level sensor relies on the composition of the solvent to provide an accurate message on the solvent level. Incorrect concentration and the presence of additives can contaminate the sensor and reduce its sensitivity.

## Production Solution

Not applicable.

## Service

If the washer solvent reservoir is full and the low solvent warning is on, proceed as follows:



# Technical Service Bulletin

---

1. Empty the reservoir and for all vehicles except A3 Sedan and A3 Cabriolet, remove the level sensor. Clean the sensor probes using all-purpose cleaner **D 009 401 04** (Figure 1) or, as an alternative, isopropyl alcohol. Reinstall the level sensor.



*Figure 1. D 009 401 04 all-purpose cleaner.*

2. For Audi A3 Sedan and A3 Cabriolet where the washer solvent level sensor is not removable the sensor probes can be cleaned by removing the reservoir, removing the filler neck from the reservoir, and gaining access to the sensor probes (Figure 2).





# Technical Service Bulletin

---

**Figure 2.** Windshield washer level sensor probes as viewed through the tank opening.

3. Saturate the tip of a cleaning brush with a rigid stem and long enough to reach the probes (approximately 10”) with all-purpose cleaner **D 009 401 04** or isopropyl alcohol. A hummingbird feeder cleaning brush is shown in the illustration but any suitable cleaning brush with a tip constructed of the appropriate material will function well for this purpose (Figure 3).



**Figure 3.** Applying all-purpose cleaner **D 009 401 04** to the tip of a hummingbird feeder cleaning brush. The cleaning brush can alternatively be saturated with isopropyl alcohol.



# Technical Service Bulletin

---

4. Thoroughly clean the sensor probes (Figure 4).



*Figure 4. Cleaning the sensor probes.*

5. Refill the reservoir with the correct type and concentration of solvent. Windshield washer fluids found in the Audi Top Service Supplies and Touch Up Paint eStore with a 35% pre-mix are suitable for temperatures down to -30 °C (-22° F) and contain no rain repellents. For freeze protection below this temperature range Windshield Washer Fluid Concentrate **ZAW 096 311 B** can be used and mixed according to the table below (Figure 5). This solvent can be adjusted for freeze protection to -32° C (-25° F), prevents washer jet contamination, particularly on the “fan” type of washer jet, and is highly effective in removing residues and insects from the windshield.



*Figure 5. ZAW 096 311 B windshield washer fluid concentrate.*

 **Note:**

Dealers in states such as California which have a restriction on windshield washer solvent VOC content can use Audi Windshield Washer Fluid – 35% pre-mix – (55 gallon) available from the Audi Top Service Supplies &



# Technical Service Bulletin

Touch-Up Paint eStore as an alternative. This solvent contains no water repellents and has freeze protection to -22° F.

- The concentration and freeze point can be checked using the T10007A refractometer (Figure 6).

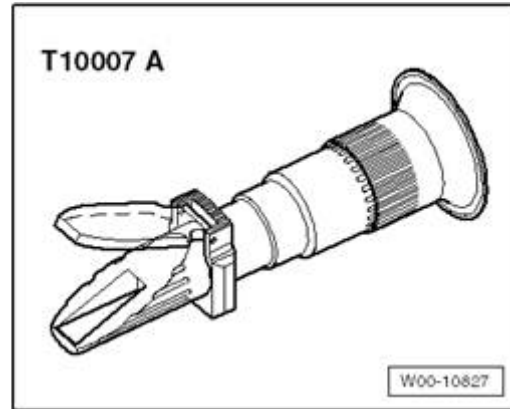

Figure 6. T10007A refractometer.

- Put a drop of washer fluid with the pipette on the glass of the refractometer. When viewing the refractometer, a light-dark border can be clearly recognized. Using the scale to the right (Figure 7), adjust the concentration of the solvent to accommodate the current weather conditions.

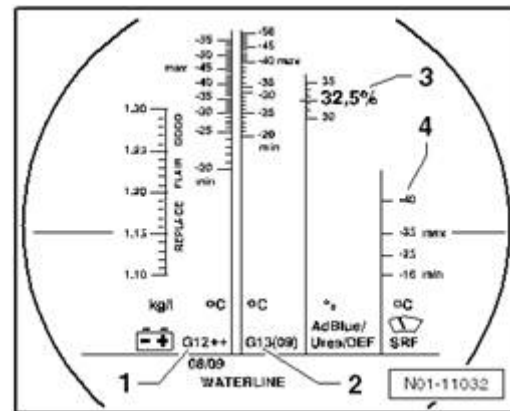

Figure 7. Scale in the view of the T10007A refractometer.

- Concentration guidelines:

Freeze protection	Windshield Washer Fluid Concentrate ZAW 096 311 B	Water
-16 °C (3° F)	1 part	3 parts
-30 °C (-22° F)	1 part	2 parts
-32 °C (-25° F)	1 part	1.5 parts

**!** Note:

It is not necessary to replace the windshield washer solvent level sensor when the cause of failure is contaminated sensor probes or incorrect washer solvent solution. Warranty claims for replacement of washer solvent level sensors that are found to not be faulty will not be reimbursed.



# Technical Service Bulletin

## Warranty

<b>Claim Type:</b>	<ul style="list-style-type: none"> <li>• 110 up to 48 Months/50,000 Miles.</li> <li>• G10 for CPO Covered Vehicles – Verify Owner.</li> <li>• If the vehicle is outside any warranty, this Technical Service Bulletin is informational only.</li> </ul>		
<b>Service Number:</b>	9258		
<b>Damage Code:</b>	0040		
	Fluid level sensor remove and reinstall	9258 19XX	See SRT with associated operations
	<b>-OR-</b>		
	Windshield washer reservoir remove and reinstall	9260 19XX	See SRT with associated operations
	Clean fluid level sensor and adjust solvent concentration	9258 2999	10 TU
<b>Diagnostic Time:</b>	GFF	No allowance	0 TU
	Road test prior to service procedure	No allowance	0 TU
	Road test after service procedure (Q4 e-tron only)	No allowance	0 TU
<b>Claim Comment:</b>	As per TSB 2038151/15		



All warranty claims submitted for payment must be in accordance with the *Audi Warranty Policies and Procedures Manual*. Claims are subject to review or audit by Audi Warranty.

## Required Parts and Tools

Always check with your Parts Department and/or ETKA for the latest information and parts bulletins.		
Part Number	Part Description	Quantity
ZAW 096 311 B (item number 128429)	Windshield Washer Fluid Concentrate	Shop Supply



# Technical Service Bulletin

<p>(Available from the Audi Top Service Supplies &amp; Touch-Up Paint eStore)</p>		
<p>Item # 121133 / Customer Item # WWFDRUM (Available from the Audi Top Service Supplies &amp; Touch-Up Paint eStore)</p>	<p>Washer solvent alternative for states with VOC restrictions</p> 	<p>Shop Supply</p>
<p>D00940104 or isopropyl alcohol</p>	<p>All-purpose cleaner</p>	<p>0.1</p>



# Technical Service Bulletin

		
See ETKA	Fasteners, Bolts, Nuts and Screws as needed per the Repair Manual	See ETKA/ELSA

Tool Number	Tool Description
T10007A	 Refractometer

## Additional Information

All parts and service references provided in this TSB (2038151) are subject to change and/or removal.

©2023 Audi of America, Inc. All rights reserved. The information contained in this document is based on the latest information available at the time of printing and is subject to the copyright and other intellectual property rights of Audi of America, Inc., its affiliated companies, and its licensors. All rights are reserved to make changes at any time without notice. No part of this document may be reproduced, stored in a retrieval system, or





# Technical Service Bulletin

---

transmitted in any form or by any means, electronic, mechanical, photocopying, recording, or otherwise, nor may these materials be modified or reposted to other sites without the prior expressed written permission of the publisher.