



GROUP	MODEL
CHA	2020MY~ Soul (SK3)
NUMBER	DATE
104 (Rev 2, 07/13/2023)	April 2020

## TECHNICAL SERVICE BULLETIN

SUBJECT:

### BRAKE AIR BLEEDING PROCEDURE FOR ESC HONKING NOISE AND SOFT/SPONGY BRAKE PEDAL

#### NOTICE

**This bulletin has been revised to include additional information. New/revised sections of this bulletin are indicated by a black bar in the margin area.**

This bulletin provides information regarding the brake air bleeding procedure for 2020MY~ Soul (SK3) vehicles equipped with Electronic Stability Control (ESC) module which may exhibit a “honk” noise when using Idle Stop and Go (ISG) and/or Hill Start Assist Control (HAC). Follow the procedure outlined in this bulletin to perform the air bleeding brake procedures below:

- A. First Manual Air Bleed Procedure - page 3
- B. HCU Forced Operation Mode (using KDS) - page 4
- C. Second Manual Air Bleed Procedure - page 5

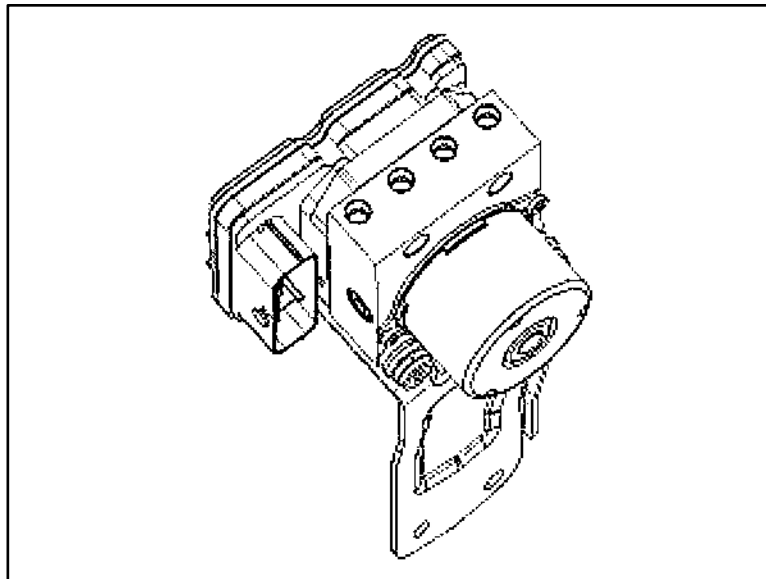

Electronic Stability Control (ESC) Module

SUBJECT:

## BRAKE AIR BLEEDING PROCEDURE FOR ESC HONKING NOISE AND SOFT/SPONGY BRAKE PEDAL

### Repair Procedure:

#### ❗ IMPORTANT

This procedure is to be performed by two (2) people:

**Technician** - Bleeds the system by manually opening and closing the brake caliper bleed screw and detects air coming out of the brake line.

**Assistant** - Operates KDS and brake pedal operation inside the vehicle.

### Preparation:

1. Lift the vehicle on hoist and remove all four (4) wheels.
2. Connect SST 09580 3D100 (A) and SST OK585 E8100 (B) to the vehicle and adjust the gauge pressure to 3 bar (43.5 psi).
3. Proceed to page 3, 'A. 1<sup>st</sup>. Manual Air Bleed Procedure'.

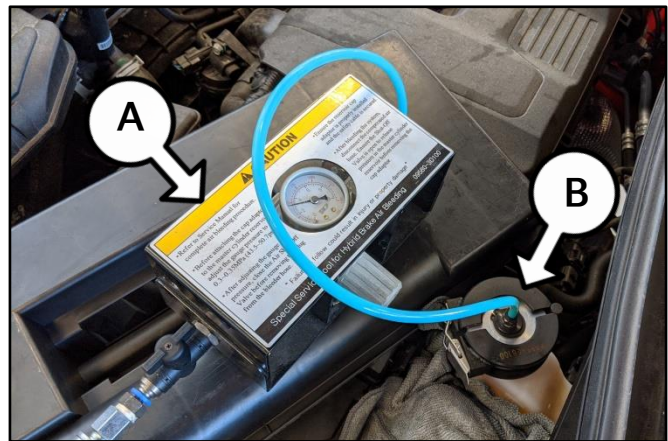

#### ⚠ CAUTION

Before bleeding, inspect the brake lines and verify no brake line fluid leaks are present.

Always use Genuine Kia DOT 4 brake fluid from a sealed container. Do not reuse the drained fluid.

Check that the brake fluid reservoir is always filled. Do not allow the brake fluid master to run out of fluid while performing air bleeding.

Ensure no dirt or foreign matter contaminates the brake fluid.

Avoid brake fluid contact with painted surfaces, as damage may occur.

Verify the assistant has the brake pedal pressed down and holds before the main worker opens/closes the caliper air bleeder screw.

SUBJECT:

## BRAKE AIR BLEEDING PROCEDURE FOR ESC HONKING NOISE AND SOFT/SPONGY BRAKE PEDAL

### A. 1<sup>st</sup>. Manual Air Bleed Procedure (Strong and Rapid Pedal Force):

Follow the air bleeding order for each wheel. Start with the right rear wheel, end with the left front wheel, and monitor the brake fluid reservoir level after each wheel is bled:

- 1) Right Rear
- 2) Left Rear
- 3) Right Front
- 4) Left Front

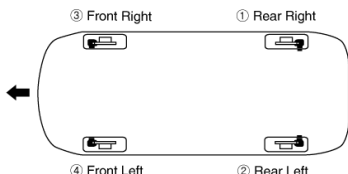

#### ⚠ CAUTION

Check that the brake fluid reservoir is always filled. Do not allow the reservoir to run out of fluid while performing air bleeding.

1. **Technician** - Using a clear hose, connect one end to the brake caliper bleed screw (A) and the other submerged in an empty container.

**Note:** Ensure that the bleed screw is closed/tightened before proceeding.

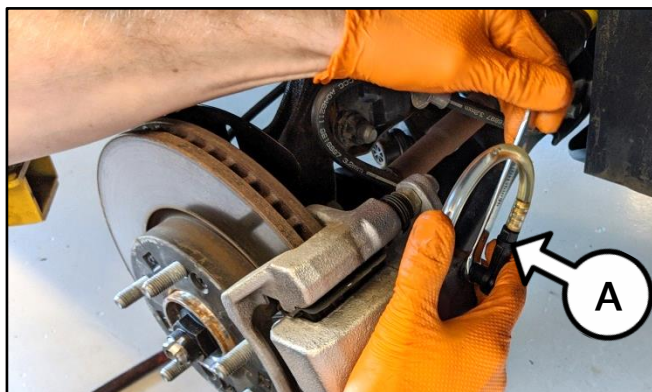

- 2a. **Assistant** - Apply strong and rapid brake pedal force by following the instruction below:

- Press and release
- Press and release
- Press and hold the brake pedal

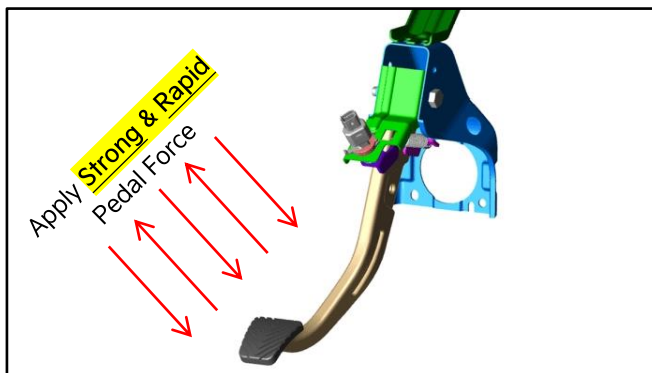

- 2b. Verbally notify out "stand by" to the technician.

- 3a. **Technician** - While assistant holds the brake pedal pressed down, slowly loosen the air bleeding screw and allow the fluid to release. Closely monitor for air bubbles by observing the fluid movement within the hose.

- 3b. Have the assistant verbally notify technician the pedal has bottomed out, then tighten the air bleed screw.



4. Repeat steps 2 - 3 as needed, until air bubbles are no longer visible.
5. Repeat steps 1 - 4 for the remaining three (3) brake calipers.
6. Proceed to page 4, '**B. HCU Forced Operation Mode (using KDS)**'.

**BRAKE AIR BLEEDING PROCEDURE FOR ESC  
HONKING NOISE AND SOFT/SPONGY BRAKE PEDAL**

SUBJECT:

**B. HCU Forced Operation Mode (using KDS):**

Follow the air bleeding order for each wheel. Start with the right rear wheel, end with the left front wheel, **and** monitor the brake fluid reservoir level after each wheel is bled:

- 1) Right Rear
- 2) Left Rear
- 3) Right Front
- 4) Left Front

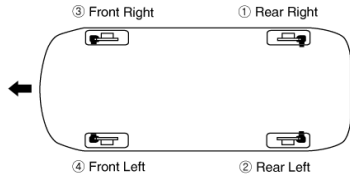

**CAUTION**

Check that the brake fluid reservoir is always filled. Do not allow the reservoir to run out of fluid while performing air bleeding.

1. **Technician** - Using a clear hose, connect one end to the brake caliper bleed screw (A) and the other submerged in an empty container.

**Note:** Ensure that the bleed screw is closed/tightened before proceeding.

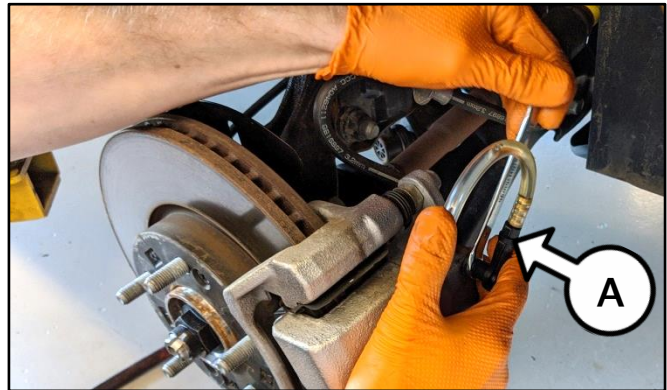

- 2a. **Assistant** - Using KDS, navigate to S/W Management → Systems → ABS/ESP, then select 'HCU Air Bleeding Mode'.

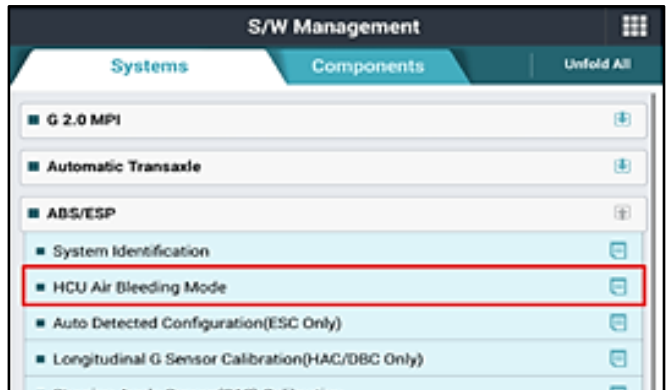

- 2b. Notify the Technician before starting, then select 'OK'.

**CAUTION**

Check that the brake fluid reservoir is always filled. Do not allow the reservoir to run out of fluid while performing air bleeding.

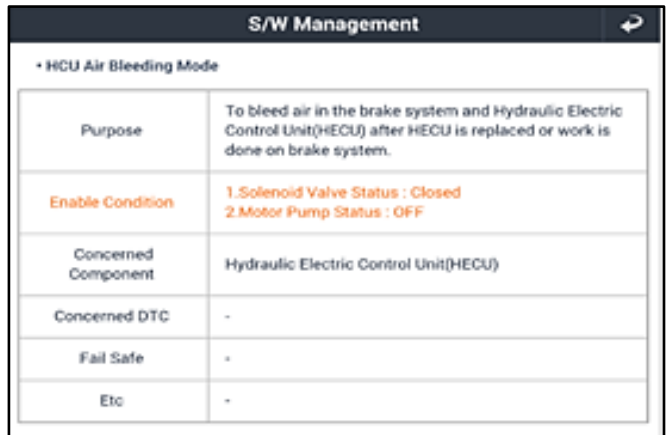

**OK**

Do not touch any system buttons while performing this function.



SUBJECT:

## BRAKE AIR BLEEDING PROCEDURE FOR ESC HONKING NOISE AND SOFT/SPONGY BRAKE PEDAL

3. Perform the following steps simultaneously as outlined:
  - a) **Technician** - Open the bleed screw as the HCU is operated by KDS.
  - b) **Assistant** - Press down on the brake pedal with strong force at regular intervals while HCU is operated by KDS.
  - c) **Technician** - Proceed with air bleeding until the air bubbles are no longer present.
  - d) **Assistant** - When HCU forced operation is completed, verbally notify the technician to stop.
  - e) **Technician** - Tighten the caliper bleed screw.
4. Repeat step 3 for the remaining three (3) wheels to complete the HCU Forced Operation Mode.
5. Proceed below to '**C. 2<sup>nd</sup>. Manual Air Bleed Procedure**'.

### C. 2<sup>nd</sup>. Manual Air Bleed Procedure (Strong and Rapid Pedal Force):

Follow the air bleeding order for each wheel. Start with the right rear wheel, end with the left front wheel, and monitor the brake fluid reservoir level after each wheel is bled:

- 1) Right Rear
- 2) Left Rear
- 3) Right Front
- 4) Left Front

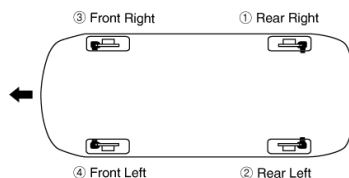

#### ! CAUTION

Check that the brake fluid reservoir is always filled. Do not allow the reservoir to run out of fluid while performing air bleeding.

1. **Technician** - Using a clear hose, connect one end to the brake caliper bleed screw (A) and the other submerged in an empty container.

**Note:** Ensure that the bleed screw is closed/tightened before proceeding.

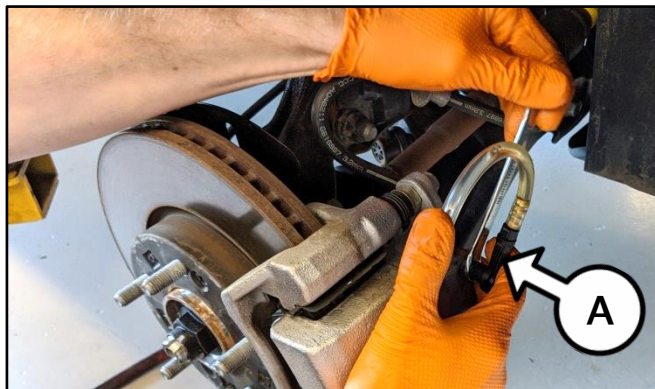

- 2a. **Assistant** - Apply **strong and rapid** brake pedal force by following the instruction below:

- Press and release
- Press and release
- Press and hold the brake pedal

- 2b. Verbally notify out "stand by" to the technician.

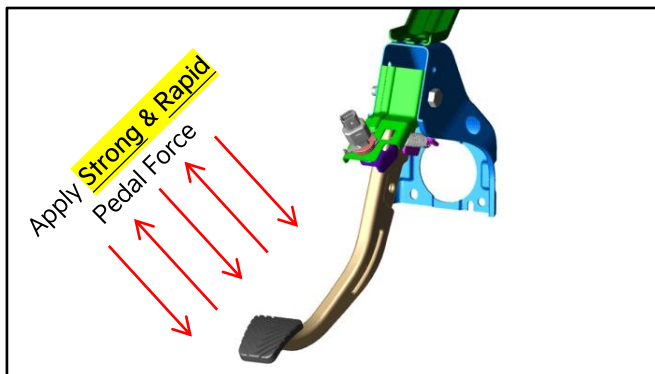

## BRAKE AIR BLEEDING PROCEDURE FOR ESC HONKING NOISE AND SOFT/SPONGY BRAKE PEDAL

SUBJECT:

- 3a. **Technician** - While assistant holds the brake pedal pressed down, slowly loosen the air bleeding screw and allow the fluid to release. Closely monitor for air bubbles by observing the fluid movement within the hose.
- 3b. Have the assistant verbally notify technician the pedal has bottomed out, then tighten the air bleed screw.



4. Repeat steps 2 - 3 as needed, until air bubbles are no longer visible.
5. Repeat steps 1 - 4 for the remaining three (3) brake calipers.
6. Check the brake pedal stroke.

**Brake Pedal Stroke Specification:**  
**5.3149 ± 0.1181 in. (135 ± 3mm)**

- If brake pedal stroke meets specification **(OK)**, remove the SST to complete the air bleeding procedure.
- If brake pedal stroke does not meet specification **(NG)**, repeat the Second Manual Air Bleed Procedure.



SUBJECT:

## BRAKE AIR BLEEDING PROCEDURE FOR ESC HONKING NOISE AND SOFT/SPONGY BRAKE PEDAL

## AFFECTED VEHICLE RANGE:

Model	Production Date Range
Soul (SK3)	November 1, 2018 ~

## REQUIRED TOOL:

Tool Name	Part Number	Figure	Comments
AHB Brake Bleeding Tool	09580 3D100		Located in SST Cabinet Drawer #7
Brake Bleeder Adapter	OK585 E8100		

For replacements, contact Snap-On Business Solutions at (888) 542-1011.

## REQUIRED PART:

Part Name	Part Number	Figure	Qty.
Brake Fluid DOT4	UM010 CH043		3 bottles (Max.)

## WARRANTY INFORMATION:

**N Code: Q41 C Code: ZZ3**

Claim Type	Causal P/N	Qty.	Repair Description	Labor Op Code	Op Time	Replacement P/N	Qty.
W	58910 K0100	0	ESC System Air Bleeding	58670F04	1.7 M/H	N/A	0