

Technical product information

Topic	Bentayga - Air suspension warning light within the DIP - DTC's P089200 - C104707 - C103B13 - Evident within Address 74
Market area	Australia E04 Bentley rest Asia and Australia (6E04),China 796 VW Import Comp. Ltd (Vico), Beijing (6796),Germany E02 Bentley rest Europe (6E02),Japan E03 Bentley Japan (6E03),Korea, (South) E08 Bentley South Korea (6E08),United Arab Emirates E06 Bentley Middle East and Africa (6E06),United Kingdom E01 Bentley UK (6E01),United States E05 Bentley USA and rest America (6E05)
Brand	Bentley
Transaction No.	2062261/5
Level	EH
Status	Approval
Release date	

Event memory entries

Diagnostic address	Event memory entry	Fault type	Fault status
0074 - Chassis control	P089200: TCM Power Relay Sense Circuit Intermittent		Intermittent
0074 - Chassis control	P089200: TCM Power Relay Sense Circuit Intermittent		static
0074 - Chassis control	C103B13: Solenoid for level control system Open circuit		static
0074 - Chassis control	C103B13: Solenoid for level control system Open circuit		Intermittent
0074 - Chassis control	C104707: Level control valves mechanical malfunction		Intermittent
0074 - Chassis control	C104707: Level control valves mechanical malfunction		static

New customer code

Object of complaint	Complaint type	Position
running gear -> shock absorber/suspension control -> roll compensation	functionality -> defective function sequence	
lighting system, signalling -> sound signals -> acoustic warning for shock absorber/suspension control	functionality -> warning signal sounds without reason	
information, navigation, communication, entertainment -> symbolic control indicators -> warning lamp for electronic stabilisation programme (ESC)	functionality -> activates without reason	
information, navigation, communication, entertainment -> symbolic information indicators -> anti-roll bar decoupling indicator	functionality -> activates without reason	

New workshop code

Object of complaint	Complaint type	Position
electrical power, electric system, data transfer -> battery management -> de-energise	functionality -> cannot be activated	
electrical power, electric system, data transfer -> power supply -> high-voltage battery	electrics -> voltage too high	

Vehicle data

Bentayga Series

Sales types

Type	MY	Brand	Designation	Engine code	Gearbox code	Final drive code
4V1*	2017	E		*	*	*
4V1*	2018	E		*	*	*
4V1*	2019	E		*	*	*
4V1*	2020	E		*	*	*
4V1*	2021	E		*	*	*
4V1*	2022	E		*	*	*
4V1*	2023	E		*	*	*
ZV1*	2023	E		*	*	*

Documents

Document name
master.xml

Bentayga - Air suspension warning light within the DIP - DTC's P089200 - C104707 - C103B13 - Evident within Address 74

Customer statement / workshop findings

Customer statement:

Air suspension warning light within the DIP

Workshop findings:

One or a combination of the DTC's shown below are evident within address 74

- P089200 - Symptom Code 3145792 - TCM Power Relay Sense Circuit Intermittent (Level Control Valves Open Circuit)
- C103B13 - 3145909 - Solenoid for level control system Open circuit
- C104707 - 3211279 - Level control valves mechanical malfunction

Technical background

Revision history

TPI 2062261/5 - Additional information has been added regarding the replacement of the air supply control unit (electrical issue) or the solenoid valve block (mechanical issue) instead of replacing the complete air supply unit

NOTE: An electrical integrity check must be conducted before replacing any parts

The solenoid valve block and/or control unit must be replaced first (symptom dependent) before replacing the air supply unit, in the event the issue is still evident and the air supply unit/compressor is suspected as being at fault, the operative must request permission via DISS before replacing the air supply control unit

Production change

-

Measure

NOTICE

Hint: Please also refer to TPI 2053492/- Air spring fault finding guidelines if the issue/symptom is not as described within this TPI

WARNING

Vehicles which use a high voltage or 48 volt system MUST only be worked on by suitably qualified personnel

WARNING

Please ensure all guidelines within the repair manual are strictly followed when working on vehicles with a high voltage or 48 volt system

1) Conduct a wiring integrity check between the valve block for adaptive suspension control unit (NX7) and the Running gear control unit (J775)

NOTE: NX7 is located as shown in Figure 1 (On the air supply unit/opposite side to the valve block)

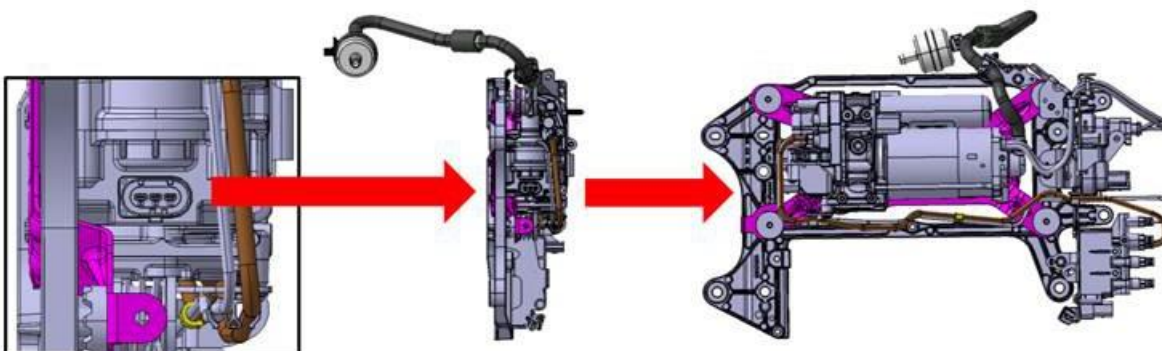

Figure 1



Please note: The pin locations are different depending on Model Year as detailed within the onward instructions:

21 Model year

T81aa Pin 79 + T3er Pin 1

T81aa Pin 59 + T3er Pin 3

T81aa Pin 35 + T10as Pin 1

T81aa Pin 75 + T10as Pin 2

20 Model year

T81aa Pin 79 + T3cs Pin 1

T81aa Pin 59 + T3cs Pin 3

T81aa Pin 35 + T10ax Pin 1

T81aa Pin 75 + T10ax Pin 2

17 to 19 Model year

T81aa Pin 79 + T3dc Pin 1

T81aa Pin 59 + T3dc Pin 3

T81aa Pin 35 + T10ax Pin 1

T81aa Pin 75 + T10ax Pin 2



TIP: Previous instances have highlighted the following after inspection:

- Broken wires
- Kinked wiring
- Pin/s missing
- Pin/s broken
- Pin/s loose

2) Repair any broken or damaged wires as per Rep.Gr 97



Should no issues be found regarding the integrity/visual checks, continue with the onward instructions

In the event that a mechanical issue is suspected please conduct step 3

Or

Should an electrical issue be suspected please conduct step 4

3) Mechanical issue

In the event a mechanical issue is suspected, the operative should continue as follows:

NOTICE

In the event that one or a combination of the issues listed below is evident the operative must respond via a new or existing DISS query, the operative should attach clear photographs of the issues found and await feedback before proceeding

- Check for water ingress within the air supply unit/valve block
- Check for water ingress within the air supply hoses
- Check the air filter is not blocked
- Should none of the afore mentioned issues be evident - Replace the solenoid valve block (Figure 2)



Hint: The solenoid valve block can be replaced without the need to remove the air supply unit assembly from the vehicle

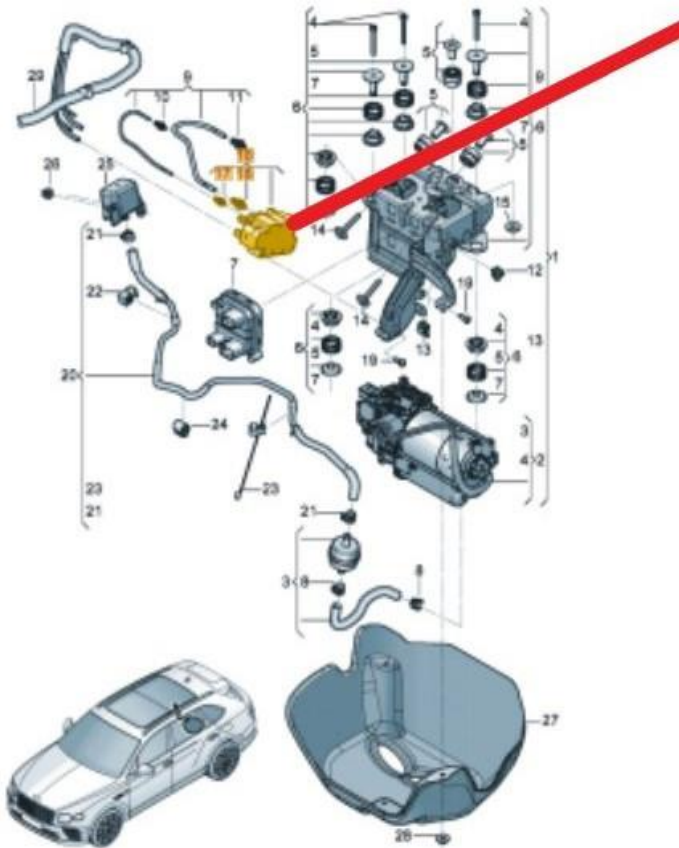

Figure 2

- Check to confirm the issue is now resolved and no DTC's are evident

NOTICE

Should the issue still be evident respond via a new or existing DISS query and await feedback before conducting any further work



Road test warranty claims will be cancelled, a road test is not required after conducting this process

4) Electrical issue

Should an electrical issue be evident issue and the wiring integrity checks were to specification, the operative should continue as follows:

- Replace the compressor control unit - Figure 3



Hint: The compressor control unit can be replaced without the need to remove the air supply assembly unit from the vehicle

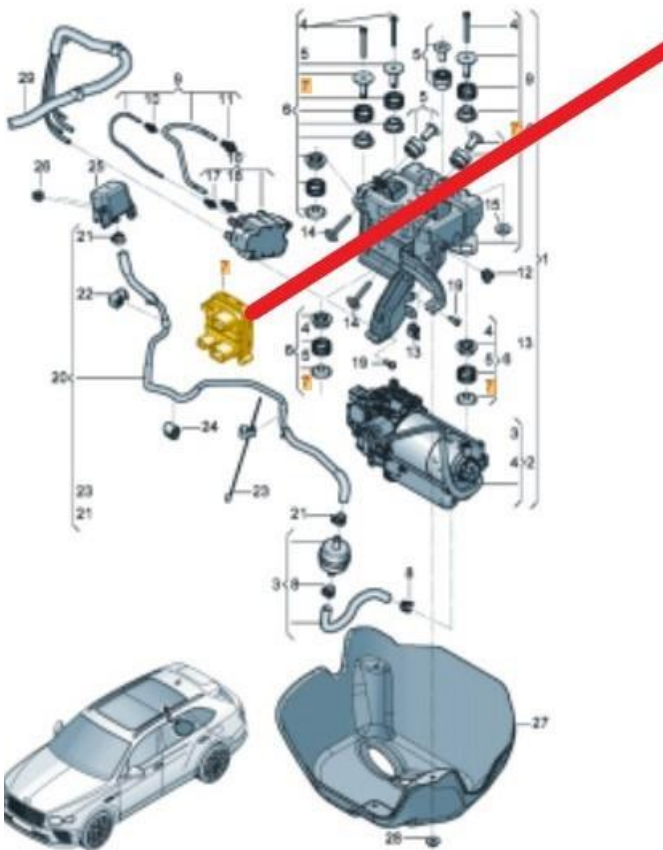

Figure 3



Hint: The control unit is secured to the air supply unit bracket using (x4) clips - To remove the control unit disengage the clips using a non metallic tool then slide/remove the control unit from the bracket (Figure 4)

TIP: The clips can easily snap - Take care when refitting the new control unit

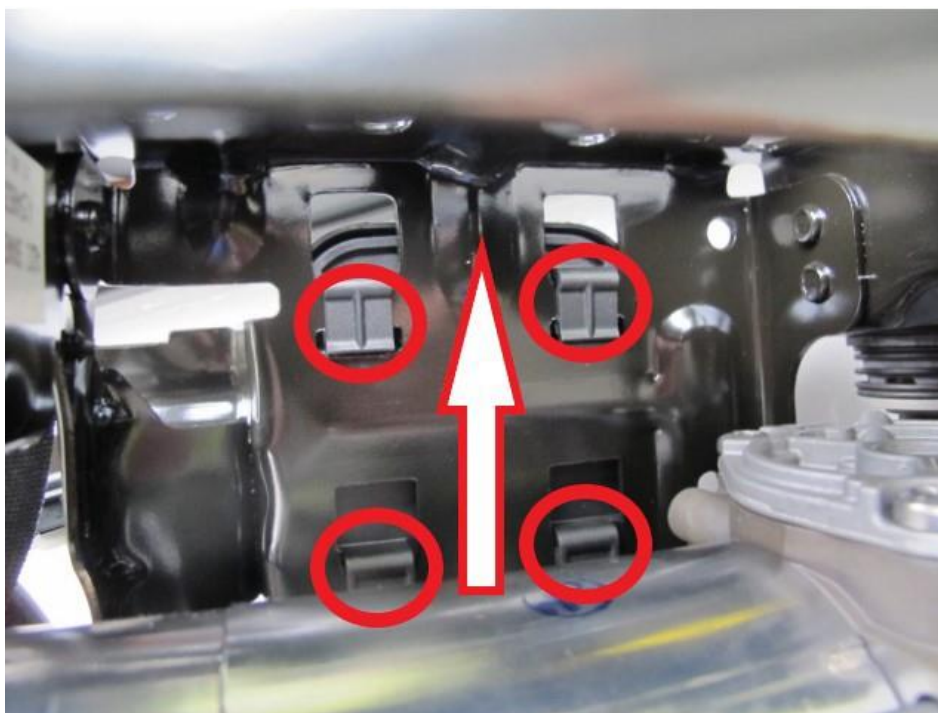

Figure 4

- On completion check to confirm the issue is now resolved and no DTC's are evident

NOTICE

Should the issue still be evident respond via a new or existing DISS query and await feedback before conducting any further work



Road test warranty claims will be cancelled, a road test is not required after conducting this process

Warranty accounting instructions

Warranty Type 110 or 910

Damage Service Number 43 23

Damage Code 00 15

Time to conduct wiring integrity checks

Labour Operation Code 43 13 01 10

Time 80 TU

Wiring repairs

Labour Operation Code 97 09 41 52

Time 40 TU

Time to replace the solenoid valve block (Mechanical operational issues/water ingress)

Labour Operation Code 43 23 19 00

Time 40 TU

Time to remove and refit the compressor control unit (Electrical issues)

Labour Operation Code 43 16 19 01 (Use 99 index until 27/07/23)

Time 20 TU

Time to remove and refit the air supply unit (Must only be claimed if permission has been granted via DISS to replace the complete air supply unit)

Labour Operation Code 43 15 19 00

Time 70 TU

Diagnosis time using ODIS

Labour Operation Code 01 50 00 00

Time as per ODIS log (Must not exceed 10 TU)

Time to energise and de-energise the 48 volt system

Labour Operation Code 93 10 00 00

Time 30 TU



Warranty claims for road test should not be submitted all road test claims will be cancelled

Parts information

Refer to the ETKA parts catalogue