



Service Bulletin

Bulletin No.: 17-NA-357

Date: June, 2023

TECHNICAL

Subject: Noise or Malfunction of Trim Door on Broken Quarter Upper Trim Panel, Possible Convertible Top Inoperative

Brand:	Model:	Model Year:		VIN:		Engine:	Transmission:
		from	to	from	to		
Chevrolet	Camaro Convertible	2016	2023	—	—	All	All

Involved Region or Country	North America, Europe, Russia, Middle East, Israel, Argentina, Brazil, Bolivia, Chile, Colombia, Ecuador, Paraguay, Peru, Uruguay, Japan, China, Taiwan, Philippines
Condition	Some customers may comment on a noise or malfunction of the trim door on a quarter upper trim panel. Upon inspection, the technician may find the quarter upper trim panel broken. Continued use, or an increased interference, may eventually render the convertible top inoperative.
Cause	The cause of the condition may be various reasons the quarter upper trim panel may break or fail.
Correction	<div style="text-align: center;"> </div> <p style="text-align: right; font-size: small;">4889567</p> <p>Note: As shown circled in the graphic above, the quarter upper trim panel design has been improved to include a 3rd retaining clip.</p> <p>Verify the condition, replace the affected quarter upper trim and possibly the quarter window regulator on that same side. Follow the vehicle build date breakpoint information noted in the Service Procedure below.</p>

Service Procedure

Important: Service agents must comply with all International, Federal, State, Provincial, and/or Local laws applicable to the activities it performs under this bulletin, including but not limited to handling, deploying, preparing, classifying, packaging, marking, labeling, and shipping dangerous goods. In the event of a conflict between the procedures set forth in this bulletin and the laws that apply to your dealership, you must follow those applicable laws.

Note: For vehicles built prior to February 14, 2017, it will also be necessary to replace the window regulator in addition to the quarter upper trim panel to accommodate the added 3rd clip design.

Important: Under no circumstances should the 3rd clip be removed from the quarter upper trim panel.

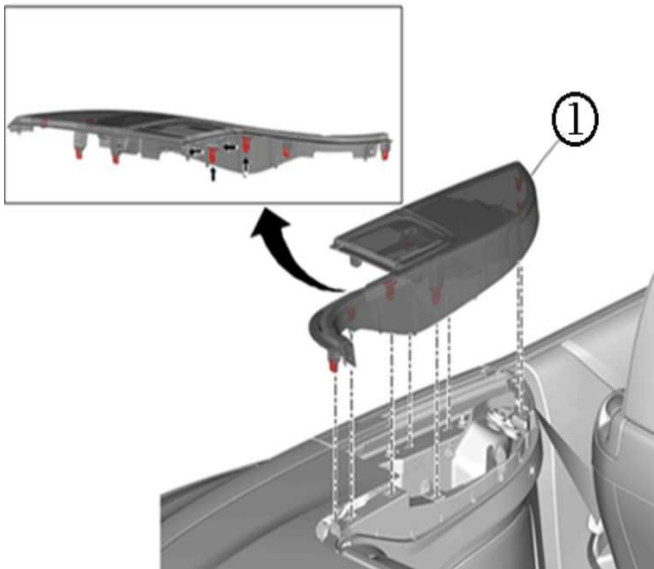

4889569

- For vehicles built February 14, 2017 and after, replace the quarter upper trim panel (1). Refer to *Quarter Upper Trim Panel Replacement* in SI.

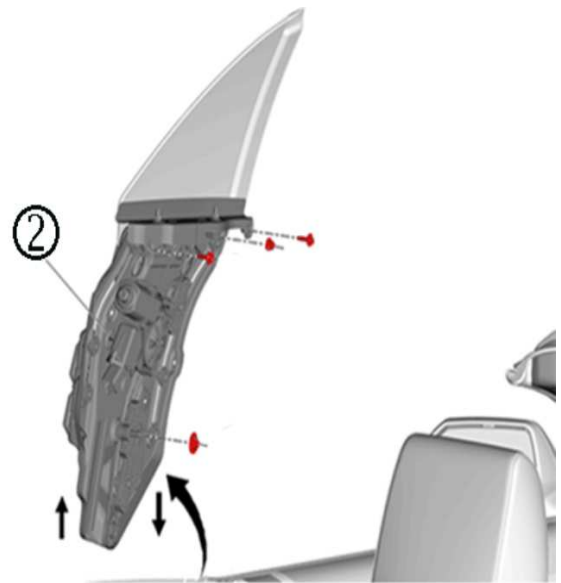

4889575

- For vehicles built prior to February 14, 2017, replace the quarter upper trim panel AND the quarter window regulator (2). Refer to *Quarter Window Regulator Replacement* in SI.

Parts Information

Causal Part	Description	Part Number	Qty
X	PANEL ASM-QTR UPR TR (RH)	84797933	1
X	PANEL ASM-QTR UPR TR (LH)	84797935	
	REGULATOR ASM-Q/WDO (RH)	84476776	As necessary
	REGULATOR ASM-Q/WDO (LH)	84476777	

Warranty Information

For vehicles repaired under the Bumper-to-Bumper coverage (Canada Base Warranty coverage), use the following labor operation. Reference the Applicable Warranties section of Investigate Vehicle History (IVH) for coverage information.

Labor Operation	Description	Labor Time
1045810	Quarter Upper Trim Panel Replacement	Use Published Labor Operation Time
1080578*	Quarter Upper Trim AND Quarter Window Regulator Replacement	0.9 hr
*This is a unique Labor Operation for bulletin use only, and should only be used for repair of vehicles built prior to February 14, 2017. The other LTG labor operation listed should be used for repair of vehicles built on/after February 14, 2017.		

Version	3
Modified	Released November 13, 2017 Revised March 19, 2021 – Added the 2019-2021 Model Years, updated the Involved Region or Country, Parts and Warranty Information sections. Revised June 22, 2023 – Added the 2022-2023 Model Years.

