



**Countries:** BAHAMAS, BOLIVIA, BELIZE, CHILE, COLOMBIA, COSTA RICA, DOMINICAN REPUBLIC, ECUADOR, EL SALVADOR, TRINIDAD AND TOBAGO, UNITED STATES, URUGUAY, VENEZUELA, MEXICO, ARUBA, NICARAGUA, PERU, Curaçao, GUATEMALA, GUYANA, HAITI, HONDURAS, JAMAICA, PANAMA

**Document ID:** IK1201482

**Availability:** ISIS, NotSIR

**Major System:** ENGINES

**Current Language:** English

**Other Languages:** [Español](#)

**Viewed:** 243

**Revision:** 5

**Created:** 5/18/2023

**Last Modified:** 6/7/2023

**Author:** Jaime Romo

[Less Info](#)

Hide Details

Coding Information

<b>Copy Link</b> 	<b>Copy Relative Link</b> 	<b>Bookmark</b>  <a href="#">View My Bookmarks</a>	<b>Add to Favorites</b> 	<b>Print</b> 	<b>Provide Feedback</b> 	<b>Helpful</b>  5	<b>Not Helpful</b>  0
----------------------	-------------------------------	--	-----------------------------	------------------	-----------------------------	-------------------------	-----------------------------

**Title:** Removal and Installation of the Air Cleaner Assembly Cover and Air Filter(s) Feature Code 0012VCB, 0012VBZ

**Applies To:** All engines in the HX and LT Chassis Equipped With the 0012VCB, 0012VBZ Air Cleaner Assembly

## CHANGE LOG

Please refer to the change log text box below for recent changes to this article:

05/26/2023 - Initial Article Release

## DESCRIPTION

This document will guide the user to identify if the cover from the air filter box was not installed correctly by not applying the correct torque spec on the screws that secures the cover.

Failure to apply correct torque spec when installing the air filter cover will create an incorrect seal in the air box cover.

## SYMPTOM(s)

DTC/Light	Description
N/A	N/A

### Customer Observations or Concerns:

- Abnormal oil sample reports
- Dirt ingestion through the intake system

## SERVICE PARTS INFORMATION

Kit Description	Part Number	Quantity Required	Notes
CLEANER, ASSEMBLY AIR DRY TYPE, DUAL ELEMENT	4063331C95	1	Replace part <b>ONLY</b> if the warpage of the part is extremely high resulting in dirt ingestion
AIR FILTER, ENGINE (Primary Filter)	2515573C1	1	If needed
AIR CLEANER, ELEMENT (Secondary filter)	2515575C2	1	If needed
P80 Water Based Lubricant	2644105R1	1	If lubricant is not available at the PDC, Locally sourced equivalent

## DIAGNOSTIC STEP(s)

 <b>WARNING:</b>	
To prevent personal injury and / or death, or damage to property, allow components in engine compartment to cool before servicing engine or vehicle.	

 <b>WARNING:</b>	
To prevent personal injury and / or death, or damage to property, park vehicle on hard flat surface, turn the engine off, set the parking brake, and install wheel chocks to prevent the vehicle from moving in both directions.	

 <b>WARNING:</b>	
To prevent personal injury and / or death, always wear safe eye protection when performing vehicle maintenance.	

1. Park vehicle on flat surface.
2. Shift transmission into Park or Neutral and set parking brake.
3. Turn ignition to Key OFF position.
4. Install wheel chocks.
5. Unlatch and open hood.

Step	Action	Decision
1	Remove air filter cover and perform an inspection of the air filters and the internal section of the air box for any signs of high level of dirt.	Yes. Go to Step 2.

	<p>Has the operator been replacing the air filters per owners manual recommendation?</p>	<p><b>No.</b> Refer to <a href="#">Operator Manual</a></p>
--	--	--

<b>Step</b>	<b>Action</b>	<b>Decision</b>
<p><b>2</b></p>	<p><b>Install air filters into the air filter box.</b></p> <p>Using a flash light inspect for signs of improper sealing or gaps between the air filter seals and the air box.</p> <p>Are there any signs of gaps or improper sealing between the air filters and air filter box?</p>	<p><b>Yes.</b> Proceed with this article. Go to the work instructions.</p> <p><b>No.</b> Perform a complete inspection of the air box for any signs of damage or loose boot clamp. Perform repairs as needed.</p>

---

## **WORK INSTRUCTION(s)**

6. Remove air filter box.

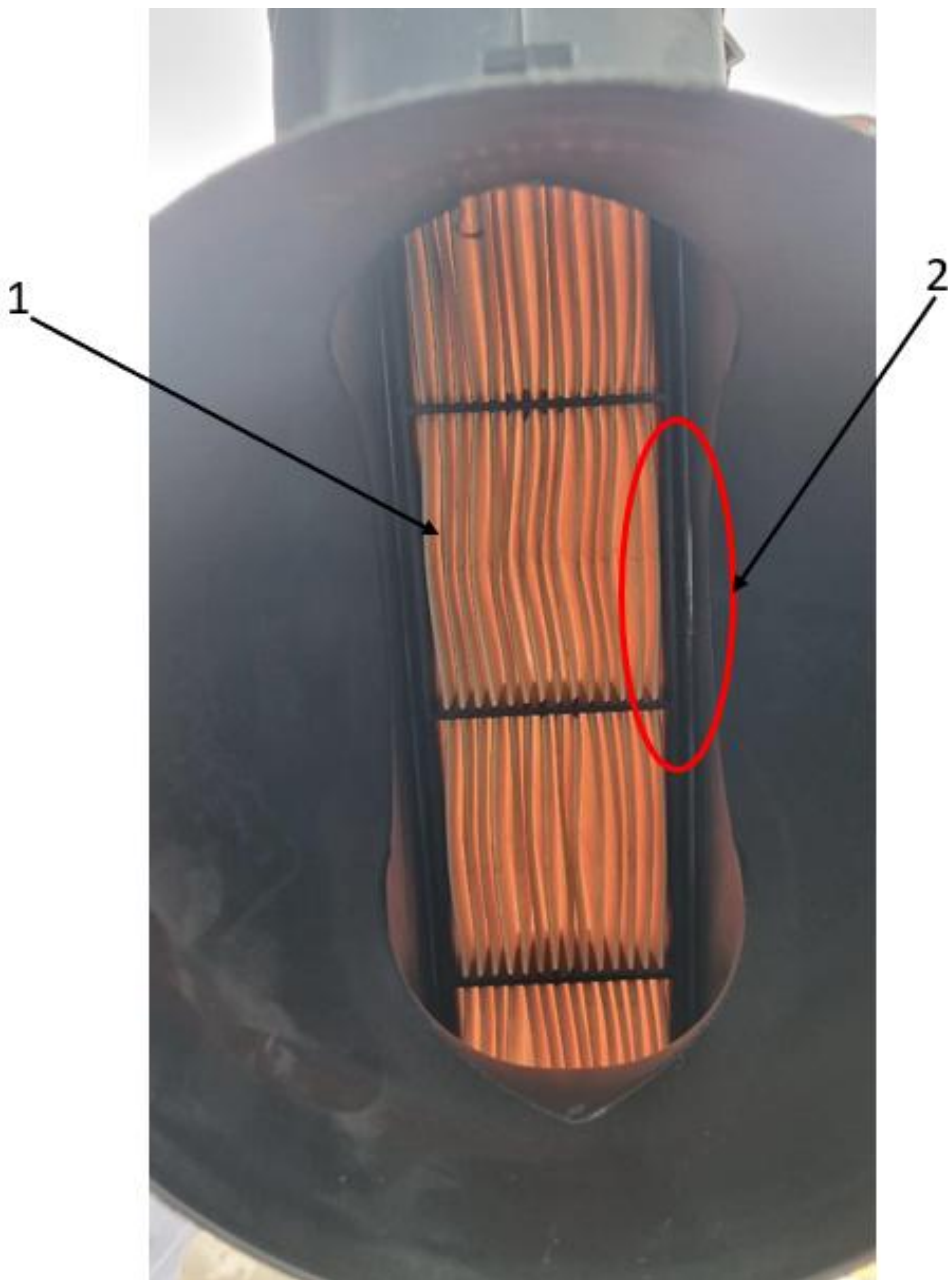

**Figure 1. Air Filter Box**

1. Air filter (Secondary filter)
2. Clearance / gap

**NOTE:**

**Do NOT re-install air filter(s), once the air filter(s) has/have been removed from the air filter assembly it needs to be discarded, re-installing old filter back to the air filter assembly may not provide a good seal between the air filter assembly and air filter(s) due to potential wear and tear of the air filter seal.**

7. Ensure secondary air filter (Figure 1, Item 1) is correctly installed and check for a presence of clearance / gap (Figure 1 and Item 2) between the air filter (Figure 1, Item 1).

a. If secondary air filter shows presence of gap between the air filter assembly and secondary filter seal, remove secondary air filter and discard. Go to Step 8.

b. If secondary air filter does not have any gaps or show any signs of gaps between the air filter assembly and secondary filter seal. Go to Step 9.

**NOTE:**

Prior to installation of the secondary air filter, ensure to apply P80 water based lubricant or equivalent around the safety seal to prevent any damage to the seal.

**NOTE:**

When installing secondary air filter, ensure it is installed with the tabs all the way down.

8. Prior to install a new secondary air filter, apply P80 water based lubricant around the seal to prevent any damage to the seal.

9. Install new primary air filter.

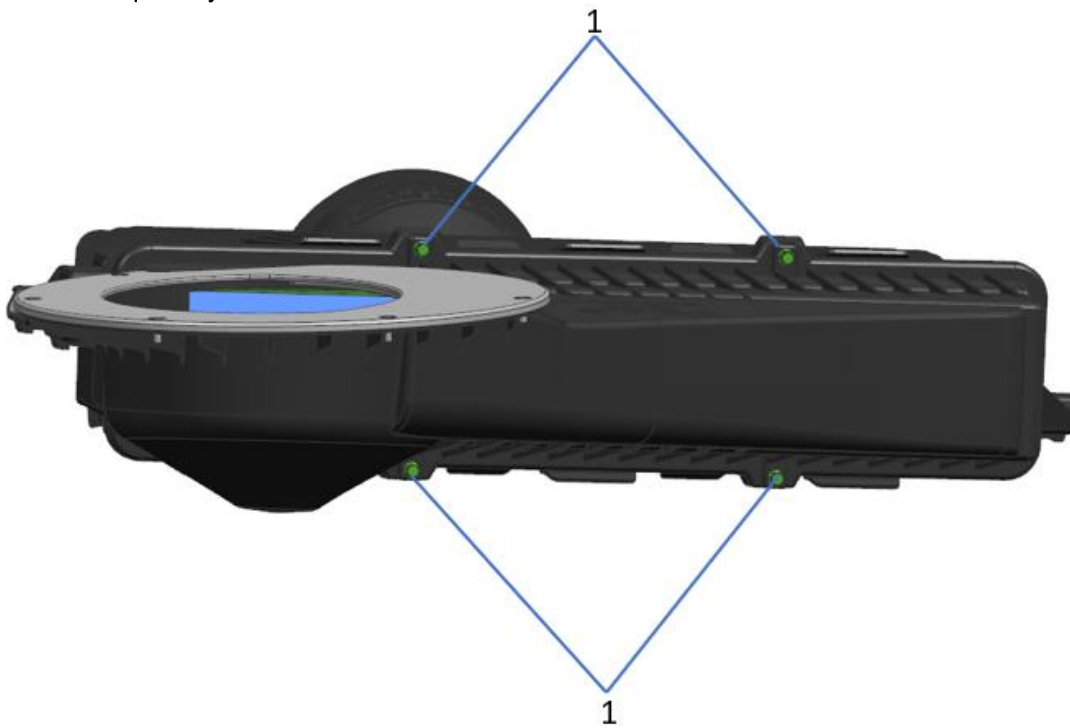
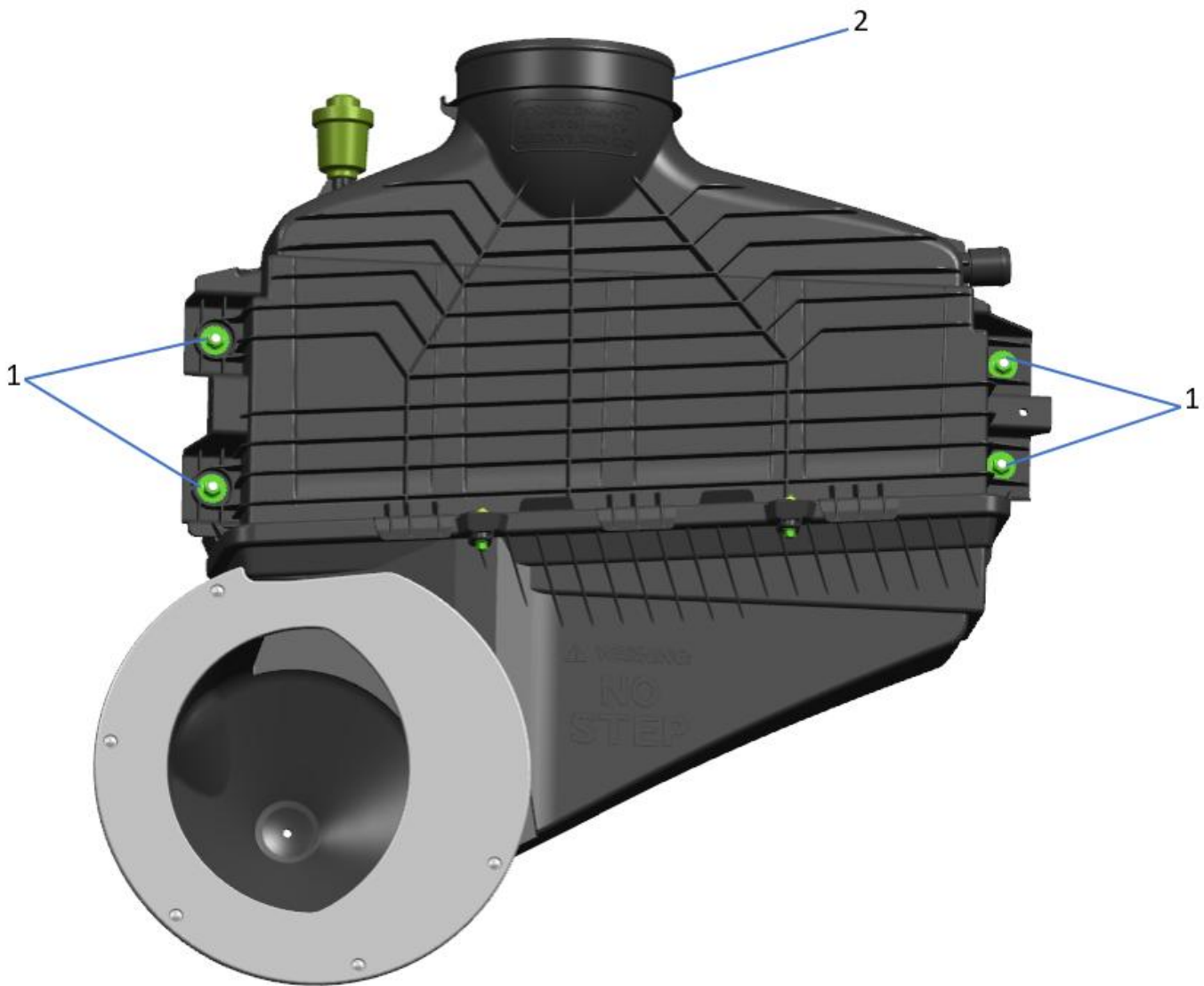

**Figure 2. Air filter Box**

1. Securing bolt (4)

10. Install air filter cover, use a torque wrench and tighten the securing bolts (Figure 2, Item 1) to 3.4 +/- 0.6Nm (30 +/- 5 in-lb).

11. Install air filter box assembly back to the vehicle.



**Figure 3. Air Box Assembly**

1. Air box assembly hold down nut (4)
2. Air filter boot clamp

12. Using a torque wrench, tighten air box assembly hold down nuts (Figure 3, Item 1) to 16 to 19 Nm (11.8 to 14 ft-lb).

13. Using a torque wrench, tighten air filter boot clamp (Figure 3, Item 2) to 4.1 to 4.5 Nm (36.2 to 39.8 in-lb).

14. Close and latch hood.

15. Remove wheel chocks.

---

## **WARRANTY INFORMATION**

### **Warranty Claim Coding:**

Refer to the [Warranty Coding Manual](#) for Group and Noun Codes.

---

### **Standard Repair Time(s):**

Refer to the [SRT Manual](#) for Repair Times

---

# OTHER RESOURCES

[Master Service Information Site](#)

 Hide Details

## Feedback Information

Viewed: 242

Helpful: 5

Not Helpful: 0

No Feedback Found