



MAZDA DEALER EMAIL

June 9, 2023

Attention: Mazda General, Parts, and Service Managers

Subject: Dealer Rework (DRW) 54 – Suspension of Delivery 2024MY CX-90 Tightening Torque Concern

Mazda Dealer Partners,

Mazda Motor Corporation has decided to take corrective action on certain 2024MY CX-90 vehicles built in Japan. **All vehicles in this campaign must be repaired prior to retail delivery, including any dealer trades.**

Concern Outline:

On thirteen CX-90 vehicles, there is a possibility that certain bolts may not be tightened completely, allowing the bolts to become loose and come off during driving. The affected Mazda dealers with these 13 vehicles in dealer stock have been contacted directly. The list of VIN's and dealers with affected inventory are below.

VIN	DLR	DEALER NAME	RGN/DIST
JM3KKCHD6R1104163	23710	OCEAN MAZDA	GUV01
JM3KKCHD7R1103586	24000	MAZDA OF PALM BEACH	GUV01
JM3KKDHC9R1103585	23925	MAZDA OF NORTH MIAMI	GUV01
JM3KKCHD0R1103641	61630	CLASSIC MAZDA WESTSIDE	MWV12
JM3KKCHD5R1103571	60233	CASCADE MAZDA	MWV12
JM3KKCHD5R1104820	50237	RAMSEY MAZDA	NEV01
JM3KKCHD8R1104178	51653	MAZDA OF NEW ROCHELLE	NEV01
JM3KKCHDXR1103968	51532	MAZDA 112	NEV03
JM3KKCHD8R1103970	51590	WERNER MAZDA	NEV04
JM3KKDHC0R1103667	50127	BURDICK MAZDA	NEV12
JM3KKDHC3R1104604	51537	MAZDA OF MILFORD	NEV13
JM3KKCHD8R1103564	51536	FAULKNER MAZDA	NEV15
JM3KKDHC5R1103597	42208	MAZDA ROSEVILLE	PAV04

Number of Affected Vehicles:

Model*	Subject VIN range	Subject build date
2024 CX-90	JM3 KK**** R1 103564 – 104820	From March 4, 2023 through March 11, 2023

* Only 13 vehicles in this range are affected.

The asterisk symbol “*” can be any letter or number. Only the vehicles identified in this campaign have this concern. The affected VIN Dealer Inventory list is available on Mazda Global Service Support (MGSS).

Action Required:

All dealer in-stock vehicles must be quarantined as soon as possible. Not repairing this DRW will directly affect the Customer Experience and cause an unnecessary return visit to your Mazda dealership. All New Car Get Ready claims submitted will be debited on vehicles sold with an open DRW. The current dealer inventory list of unsold vehicles is on Mazda Global Service Support (MGSS) under campaign DRW54

Outline of Repair:

The repair is to check tightening torque of certain bolts in the vehicle suspension. Dealer Inventory, Warranty Information and Repair Procedures will be available on Mazda Global Service Support (MGSS) by end of day, June 09, 2023, and keyword searching in MGSS may not be available until the next business day. Affected vehicles will display DRW54 at the time of announcement when checking the vin for a warranty vehicle inquiry.

We apologize for any inconvenience this Dealer Rework may cause you and your customers. Your understanding and support in carrying out this campaign is greatly appreciated.

If you have any questions regarding this DRW, please fill out the Dealer Recall Help Form located on [OneMazda](#) or contact the Mazda Warranty Department at warrantydept@mazdausa.com.

Note, any vehicle sold with an open DRW, and a New Car Ready claim submitted and paid will have the NCR claim debited.

Sincerely,
Travis Young
Manager, Recalls, Technical Services Division
Mazda North American Operations

CX-90 DRW54 REPAIR PROCEDURE
SUSPENSION AND STEERING
TIGHTENING TORQUE CONCERN

1. Subject vehicles

2024MY CX-90 vehicles

- Subject VIN and production date ranges:

Model	Subject VIN range	Subject production date range
2024 CX-90	JM3 KK**** R1 103564 – 104820	From March 4, 2023 through March 11, 2023

- Number of subject vehicles: 17 units

Note: At dealers: 14 vehicles

2. Outline of concern

On the subject CX-9 vehicles, there is a possibility that certain bolts may not be tightened completely, allowing the bolts to become loose and come off during driving.

Potentially affected bolts:

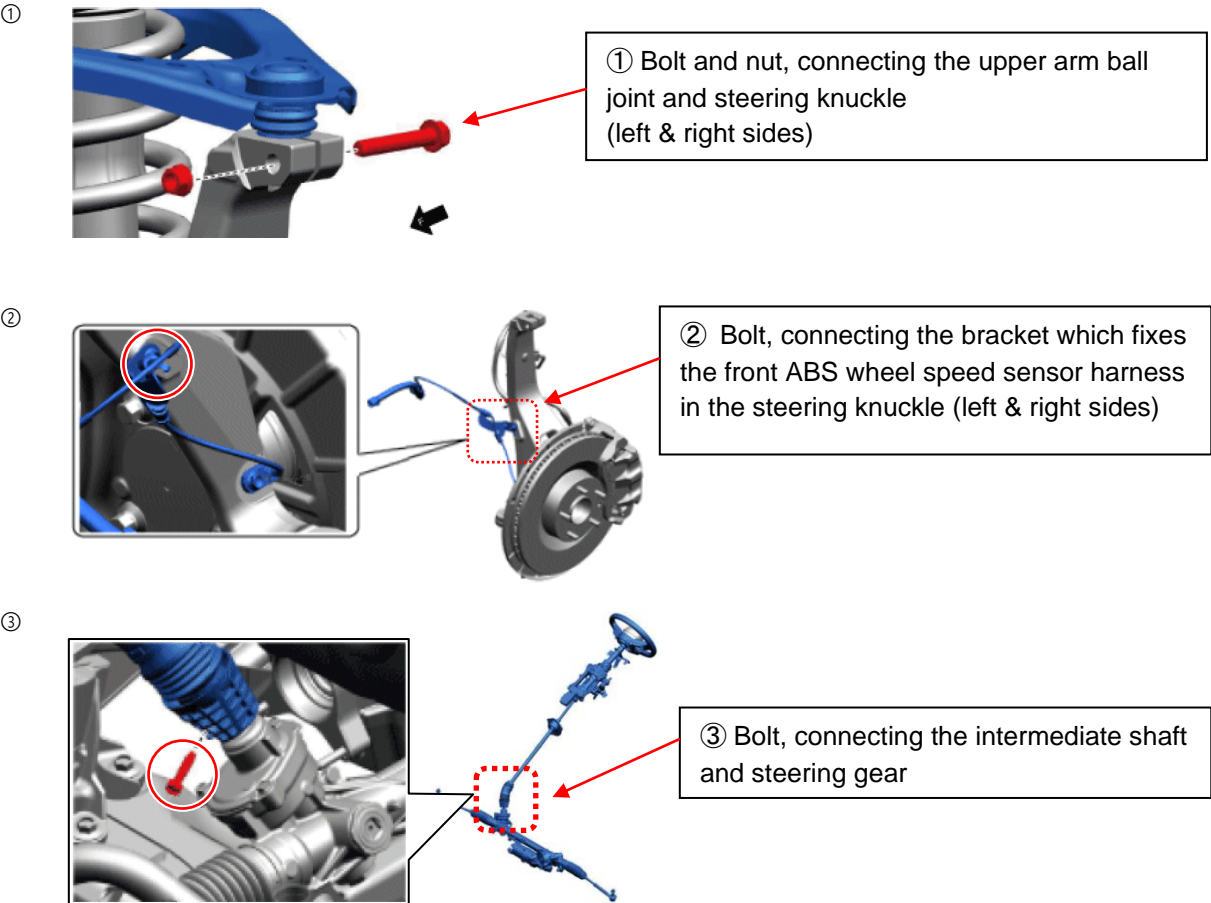

3. Repair Procedure

- A) Lift the vehicle
- B) Inspect and Tighten the LH and RH Front Upper Control Arm Ball Joint Bolt to Steering Knuckle and ensure the ball joint is fully inserted into the Steering Knuckle
 - a. Torque the Bolt to 42.5 N·m {4.3 kgf·m, 31.15 ft·lbf}

The figure shows the driver's side (same as passenger's side)

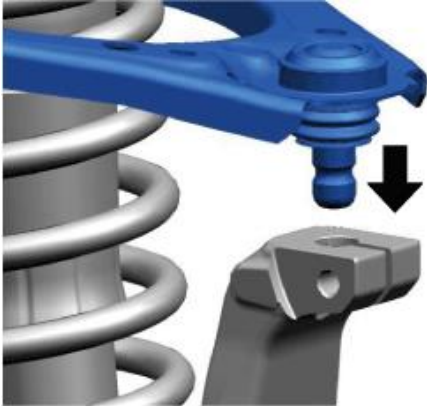

• The figure shows the driver's side (same as passenger's side).

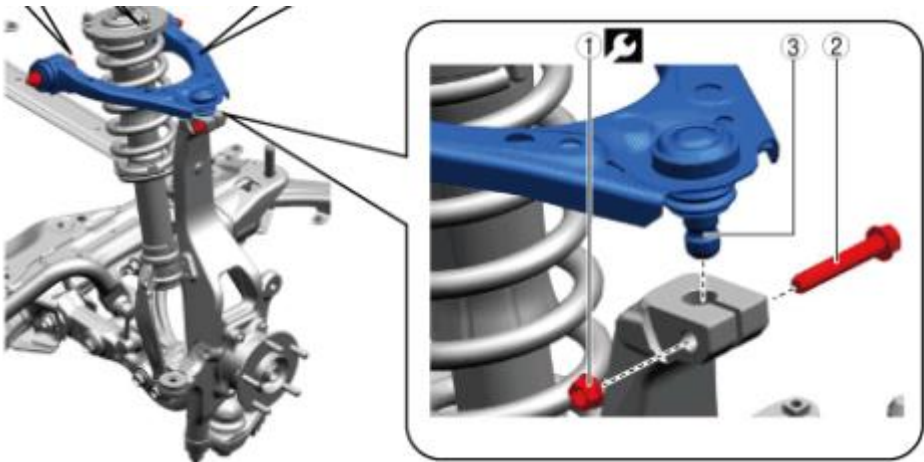
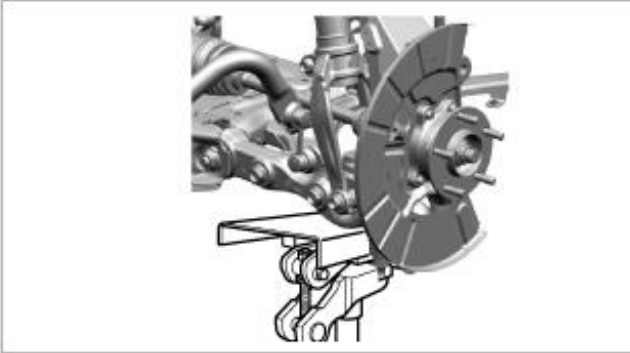

Procedure	Part name	Applicable condition	
1	Nut	Continuous	42.5 N·m {4.3 kgf·m, 31.15 ft·lbf}
2	Bolt	Continuous	—
3	Front upper arm ball joint	Continuous	—

Replace the bolt and nut if they are missing.

- C) Inspect and tighten the LH and RH Front ABS Wheel Sensor Bracket to the Steering Knuckle to 82in-lbf, or 9.5N-m. Inspect Bolt 5.

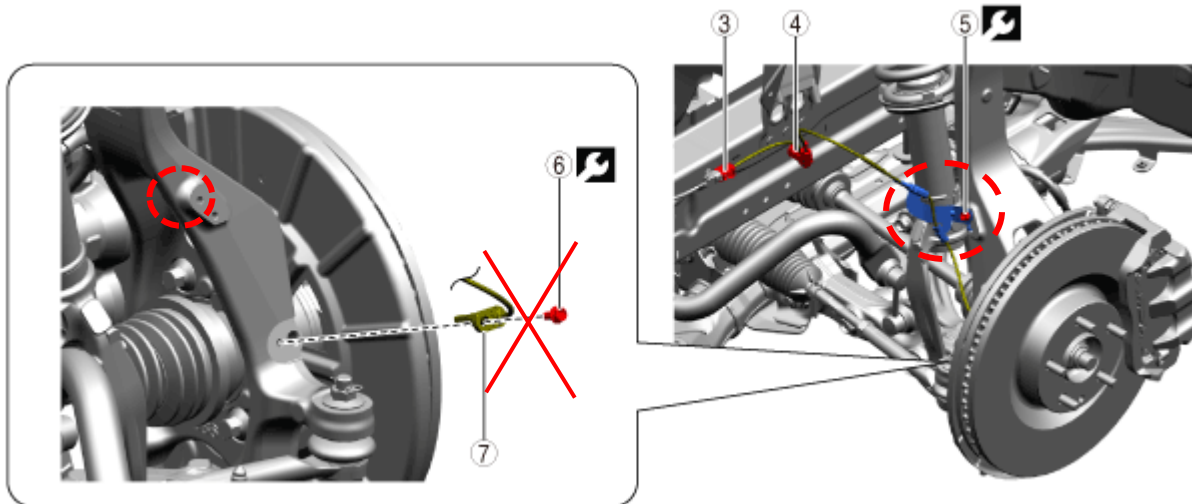

5	Bolt	Continuous	9.5 N·m {95 kgf·cm, 82 in·lbf}
6	Bolt	Continuous	9.5 N·m {95 kgf·cm, 82 in·lbf}

Note: If the bolt is missing, replace the missing bolt. Follow the WSM procedure on MGSS if the bolt is missing.

- D) Inspect and Tighten the Intermediate Steering Shaft Bolt to Steering Gear to 29 N·m {2.95 kgf·m, 21.4 ft·lbf}. Note this bolt is a "R" part but can be tightened if not torqued to spec. Access to this bolt is located in the engine bay.

NOTE: Rotate the steering wheel until the joint bolt on the steering column side and steering gear side reaches the removal position. See photo and diagram below.

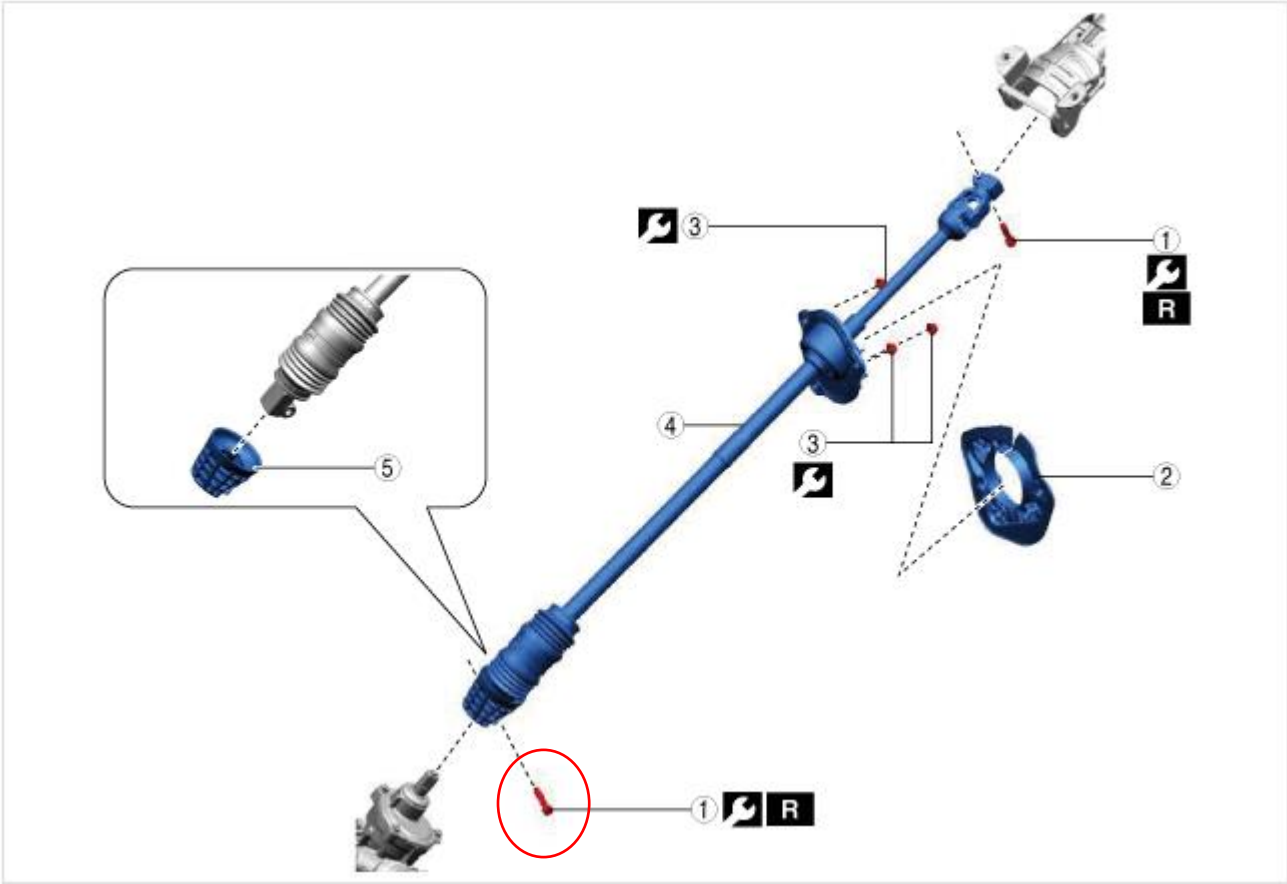

Procedure	Part name	Applicable condition		
1	Joint bolt	Continuous	Replacement part	29 N·m {2.95 kgf·m, 21.4 ft·lbf}



E) Clean off any fingerprints and test drive for proper operation.



Subject: DRW54 - SUSPENSION OF DELIVERY - 2024 CX-90 TORQUE TIGHTENING CONCERN	Campaign No.: DRW54
	Last Issued : 06/09/2023

DESCRIPTION

Mazda Dealer Partners (Dealer Communication was only sent to the Dealer's below),

Mazda Motor Corporation has decided to take corrective action on certain 2024MY CX-90 vehicles built in Japan. **All vehicles in this campaign must be repaired prior to retail delivery, including any dealer trades.**

Concern Outline:

On thirteen CX-90 vehicles, there is a possibility that certain bolts may not be tightened completely, allowing the bolts to become loose and come off during driving. The affected Mazda dealers with these 13 vehicles in dealer stock have been contacted directly. The list of VIN's and dealers with affected inventory are below.

VIN	DLR	DEALER NAME	RGN/DIST
JM3KKCHD6R1104163	23710	OCEAN MAZDA	GUV01
JM3KKCHD7R1103586	24000	MAZDA OF PALM BEACH	GUV01
JM3KKDHC9R1103585	23925	MAZDA OF NORTH MIAMI	GUV01
JM3KKCHD0R1103641	61630	CLASSIC MAZDA WESTSIDE	MWV12
JM3KKCHD5R1103571	60233	CASCADE MAZDA	MWV12
JM3KKCHD5R1104820	50237	RAMSEY MAZDA	NEV01
JM3KKCHD8R1104178	51653	MAZDA OF NEW ROCHELLE	NEV01
JM3KKCHDXR1103968	51532	MAZDA 112	NEV03
JM3KKCHD8R1103970	51590	WERNER MAZDA	NEV04
JM3KKDHC0R1103667	50127	BURDICK MAZDA	NEV12
JM3KKDHC3R1104604	51537	MAZDA OF MILFORD	NEV13
JM3KKCHD8R1103564	51536	FAULKNER MAZDA	NEV15
JM3KKDHC5R1103597	42208	MAZDA ROSEVILLE	PAV04

Number of Affected Vehicles:

Model*	Subject VIN range	Subject build date
2024 CX-90	JM3 KK**** R1 103564 – 104820	From March 4, 2023 through March 11, 2023

* Only 13 vehicles in this range are affected.

CONSUMER NOTICE: The information and instructions in this bulletin are intended for use by skilled technicians. Mazda technicians utilize the proper tools/ equipment and take training to correctly and safely maintain Mazda vehicles. These instructions should not be performed by "do-it-yourselfers." Customers should not assume this bulletin applies to their vehicle or that their vehicle will develop the described concern. To determine if the information applies, customers should contact their nearest authorized Mazda dealership. Mazda North American Operations reserves the right to alter the specifications and contents of this bulletin without obligation or advance notice. All rights reserved. No part of this bulletin may be reproduced in any form or by any means, electronic or mechanical--including photocopying and recording and the use of any kind of information storage and retrieval system ---without permission in writing.

The asterisk symbol "*" can be any letter or number. Only the vehicles identified in this campaign have this concern. The affected VIN Dealer Inventory list is available on Mazda Global Service Support (MGSS).

Action Required:

All dealer in-stock vehicles must be quarantined as soon as possible. Not repairing this DRW will directly affect the Customer Experience and cause an unnecessary return visit to your Mazda dealership. All New Car Get Ready claims submitted will be debited on vehicles sold with an open DRW. The current dealer inventory list of unsold vehicles is on Mazda Global Service Support (MGSS) under campaign DRW54

CONSUMER NOTICE: The information and instructions in this bulletin are intended for use by skilled technicians. Mazda technicians utilize the proper tools/ equipment and take training to correctly and safely maintain Mazda vehicles. These instructions should not be performed by "do-it-yourselfers." Customers should not assume this bulletin applies to their vehicle or that their vehicle will develop the described concern. To determine if the information applies, customers should contact their nearest authorized Mazda dealership. Mazda North American Operations reserves the right to alter the specifications and contents of this bulletin without obligation or advance notice. All rights reserved. No part of this bulletin may be reproduced in any form or by any means, electronic or mechanical---including photocopying and recording and the use of any kind of information storage and retrieval system ---without permission in writing.