



Technical Service Bulletin

GROUP CAMPAIGN	NUMBER 23-01-052H
DATE JUNE, 2023	MODEL(S) TUCSON HYBRID (NX4 HEV) & SANTA FE HYBRID (TM HEV)

SUBJECT: COOLING SYSTEM CIRCUIT DEBRIS DISCHARGE AND COOLANT CHANGE (SERVICE CAMPAIGN T9L)

* IMPORTANT

Dealers must perform this service campaign on all affected vehicles prior to customer retail delivery and whenever an affected vehicle is in the shop for any maintenance or repair.

Access the "Vehicle Information" screen via WEBDCS to identify open campaigns.

DESCRIPTION: This bulletin provides information related to the cleaning of the cooling system and coolant change to address the following problem:

- "Refill Inverter Coolant" warning light displayed on the cluster
- No DTC's present
- Normal level of coolant in Inverter Reservoir Tank
- Measured EWP Speed > 2,800 RPM

The cause of the warning light is due to increased EWP Speed due to poor flow of coolant inside the cooling circuit. The coolant in the system will be discharged and any foreign substances in the circuit will be flushed out with new coolant added in the end. A new reservoir cap label will be added.

STUI



As outlined in the Digital Documentation Policy, all claims require VIN and Mileage validation through VCI connection or photo capture. Additionally, please ensure the repair Part photo requirement is completed according to the steps in the TSB. **All claims submitted that have incomplete, illegible, or missing documentation are subject to debit.**

APPLICABLE VEHICLES (Certain):

- 2022MY Tucson Hybrid (NX4 HEV) equipped with 1.6L Gamma II turbocharged engines and produced from 01/21/2021– 10/30/2021.
- 2021-22MY Santa Fe Hybrid (TM HEV) equipped with 1.6L Gamma II turbocharged engines and produced 12/18/2020 – 09/27/2021.

i Information

- To ensure proper understanding of the service procedure and equipment connections, it is recommended to view or print this bulletin in color.
- When working on the vehicle, ensure to disconnect the high voltage system and wear protective eye safety goggles to avoid injury from coolant leaks under pressure.
- To securely connect the equipment hoses, use existing coolant hose clamps at the identified locations on the vehicle as the equipment flushes coolant under pressure.

PARTS INFORMATION:

Part Name	Part Number	Quantity
Coolant (LLC-10)	00232-19098	1 gal.
Reservoir Cap Label	25328-B1000QQH	1

SST INFORMATION:

Tool Name	Figure	Part Number	Quantity	Remarks
Coolant Flushing Equipment Set		KQ253-CV158QQH	1	Each dealer will be shipped one free of charge

WARRANTY INFORMATION:

Model	Op Code	Operation	Causal Part	Op Time	Nature Code	Cause Code
Tucson Hybrid (NX4 HEV)	20D142R1	COOLING SYSTEM CIRCUIT DEBRIS DISCHARGE, COOLANT CHANGE, AND RESERVOIR CAP LABEL REPLACEMENT	25328-B1000QQH	0.7 M/H	E83	ZZ5
Santa Fe Hybrid (TM HEV)	20D142R3					
Tucson Hybrid (NX4 HEV) & Santa Fe Hybrid (TM HEV)	20D142R5	COOLANT CHECK ONLY	25328-B1000QQH	0.3 M/H		

NOTE 1: Submit claim on Claim Entry Screen as "Campaign" type.

NOTE 2: If a part that is not covered by this campaign is found in need of replacement while performing the Service Campaign and the affected part is still under warranty, submit a separate claim using the same repair order. If the affected part is out of warranty, submit a Prior Approval request for goodwill consideration prior to the repair.

NOTE 3: Op times include VIN, Mileage and Part (if applicable) validation. **All claims submitted that have incomplete, illegible, or missing documentation are subject to debit.**

COOLANT FLUSH AND FILTER EQUIPMENT OPERATING INSTRUCTIONS:

1. Air Draining (Coolant discharge)

- a. When discharging the remaining coolant using air, turn off the coolant pump and close the inlet valve. (If the inlet valve is opened, the air may flow back and the remaining coolant may not be recovered.)
- b. Equipment setting condition:
 - i. **Air 'ON', Pump 'OFF', Inlet valve 'OFF'**

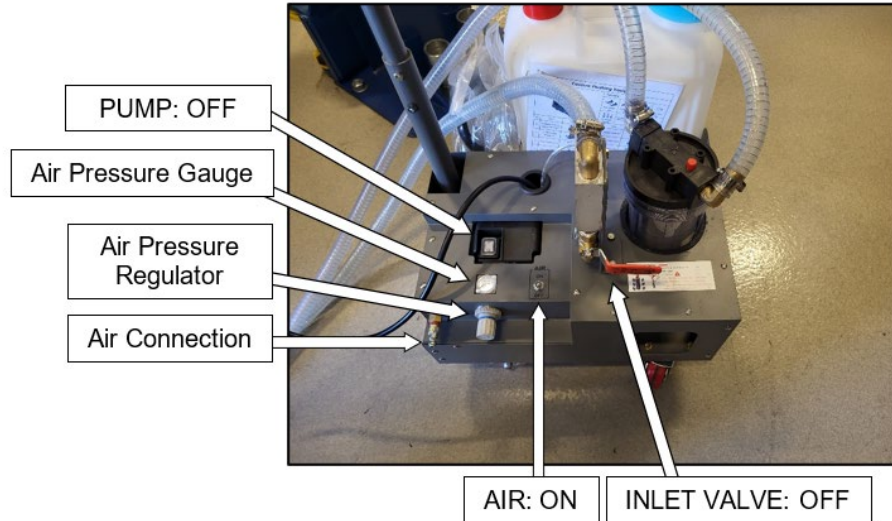

- c. The air pressure can be adjusted up to 3 bar to achieve desired draining performance.

2. Coolant Cleaning (Flushing and filtering of the vehicle's coolant circuit)

- a. Equipment setting condition:
 - i. **Pressure 2 bar, Air 'ON', Pump 'ON', Inlet valve 'ON'**

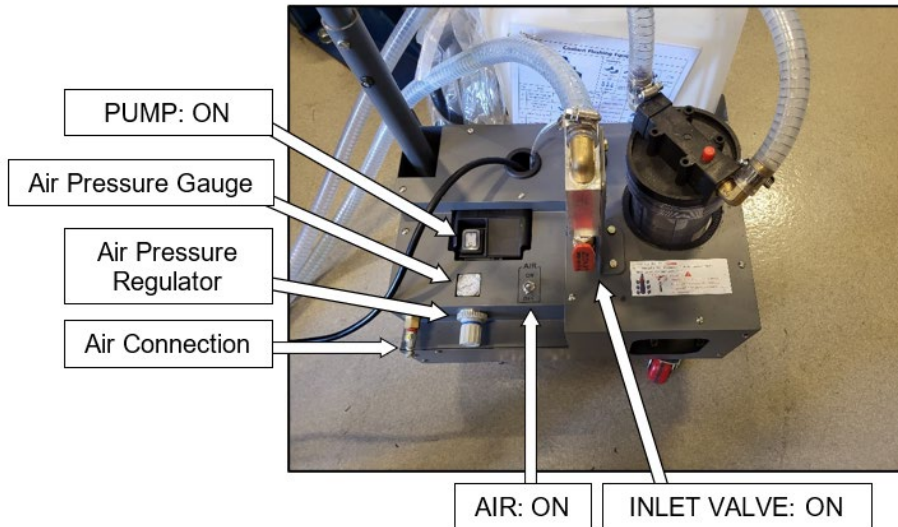

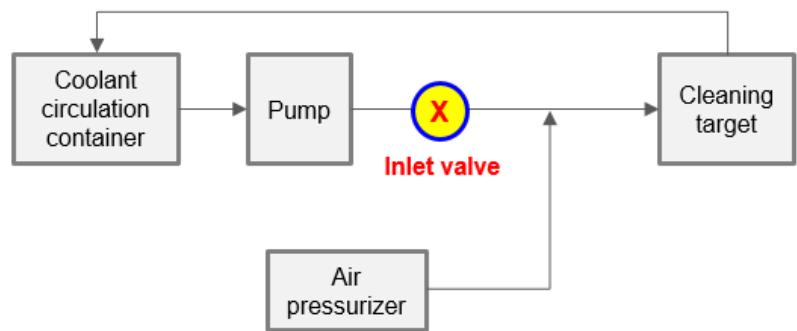
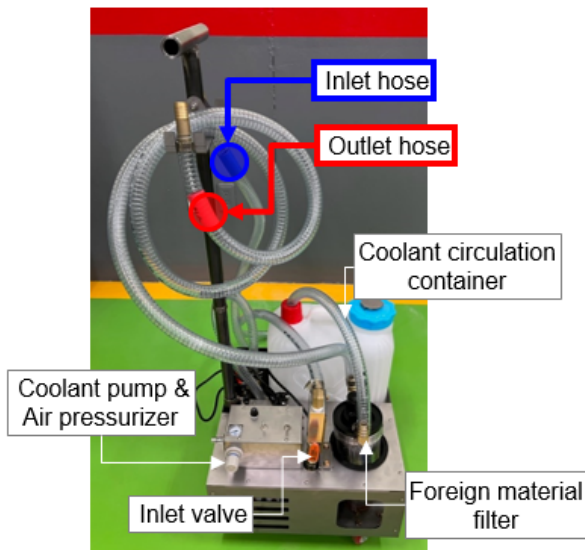

CAUTION

The coolant circulation container must always have 8L (about half of the reservoir bottle) of either tap water, distilled water or coolant (blue BSC-2) that was discharged from the previous vehicle. Never use salty or light water in the coolant circulation container.

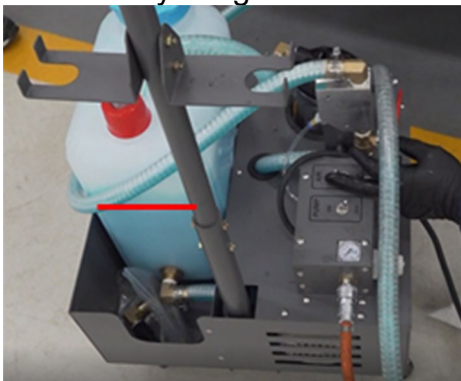

- For cleaning equipment, make sure to turn on the water pump first and then turn on the air. After turning on the air, visually check whether the air comes out from the end of the inlet of the equipment. When air does not come out, operate the air pressure valve to increase the pressure a little to check that air comes out and set it to 2 bar.
- **Please ensure that only Blue Coolant (BSC-2) is used in the Coolant Flushing Equipment Set when flushing the system. Disconnect the Coolant Flushing Equipment Set before filling vehicle systems with Pink Coolant (LLC-10). This ensures that no Pink Coolant is mixed with the Blue Coolant.**

NOTICE

After one cleaning operation is completed, clean the filter & filter case of the equipment with an air gun to remove foreign substances.

- Ensure to remove as much of the foreign substances as possible.
- A poorly cleaned filter can result in decreased flow rate and degrade the cleaning effect of the cleaning machine.

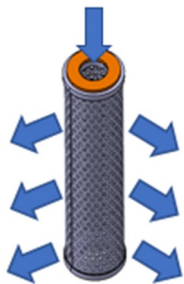

- Sludge can get stuck to the inner wall of the filter gaps, be sure to clean the filter evenly.

**WARNING**

- When working on the high voltage system, make sure that you are familiar and comply with the "Safety Precautions, Cautions and Warnings." If you do not comply with the instructions, death or serious injury due to electric shock or leakage may occur.
- When working on the high voltage system, make sure to cut off the high voltage first according to the "High Voltage Cut-off Procedure." If you do not comply with the instructions, death or serious injury due to electric shock or leakage may occur.

CAUTION

- Be sure to wear sufficient eye protection (safety goggles) when connecting or disconnecting hoses to the vehicle and when operating the coolant cleaning equipment until you have verified coolant discharge and cleaning is operating properly. An accidental discharge may occur and fluid may enter your eyes if you do not follow this precaution.

VEHICLE SERVICE PROCEDURE – DEBRIS DISCHARGE AND COOLANT CHANGE

1. Check for blue coolant inside the inverter reservoir tank. (Keep hood opened)

CAUTION

Do not proceed with the operation on pink coolant vehicles.

If pink coolant is found, proceed to Step 17.

2. Using the GDS under “Data Analysis”, monitor the initial RPM of the EWP when starting vehicle to confirm Coolant Supplement warning.
 - Spec is 2,000 – 2,800 RPM
 - “Coolant Supplement” displayed above 2,800 RPM.
3. Turn off the vehicle and remove the service interlock connector (A).



4. Remove the reservoir tank cap (B) then remove the coolant from inside the tank using the Javara Hose.
 - Use a bucket to catch the coolant that comes out from the discharge side of the Javara Hose as seen in the photo.



Javara Hose

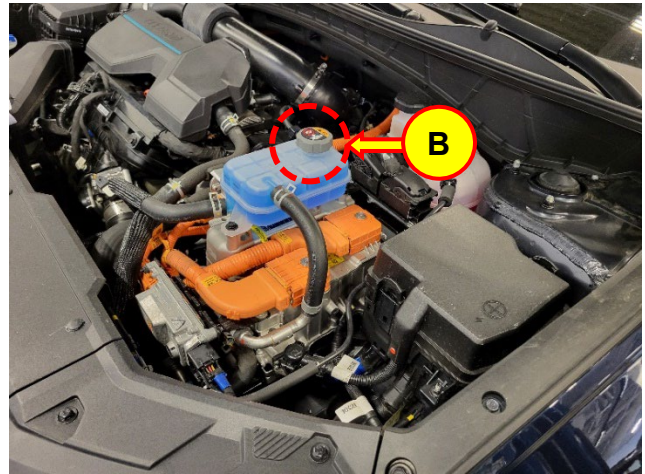

5. Disconnect the two hoses from **the reservoir tank** and connect them to the cleaning equipment as follows:

- Circulation inlet hose **Blue** to the hose located **on the left side of the reservoir tank**.
- Circulation outlet hose **Red** to the hose located **on the right side of the reservoir tank**.
- Circulate coolant and air to perform a 3-minute cleaning.

6. While the cleaning equipment is in operation, remove the reservoir tank to clean the residual coolant and debris inside.

- Use tap or distilled water to flush out thoroughly ensuring there is no blue coolant residual visible.
- Once thoroughly flushed out, use an air tool to dry out the reservoir.



7. After 3 minutes, turn off the coolant pump in the cleaning equipment and allow air to blow through the system for 30 seconds. Turn off the air to the cleaning equipment.

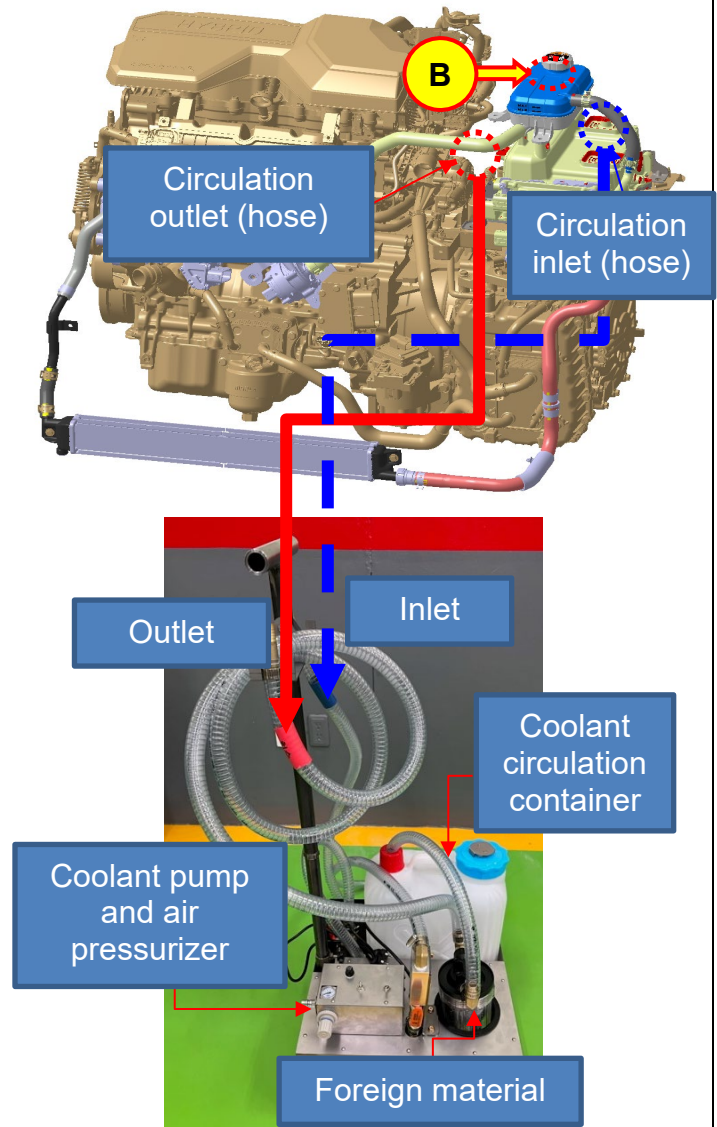

8. Reverse the hose connections from step 5.
 - Circulation outlet hose **Red** to the hose located **on the right side of the reservoir tank**.
 - Circulation inlet hose **Blue** to the hose located **on the left side of the reservoir tank**.
 - Circulate coolant and air to perform a 3-minute cleaning.
9. Repeat operation 7.
 - After 3 minutes, turn off the coolant pump in the cleaning equipment and allow air to blow through the system for 30 seconds. Turn off the air to the cleaning equipment.
10. Repeat operation 5.
 - Circulation inlet hose **Blue** to the hose located **on the left side of the reservoir tank**.
 - Circulation outlet hose **Red** to the hose located **on the right side of the reservoir tank**.
 - Circulate coolant and air to perform a 3-minute cleaning.
11. After 3 minutes, turn off the coolant pump in the cleaning equipment and allow air to blow through the system for 1 minute. Turn off the air to the cleaning equipment.
12. Confirm that all coolant hoses are properly installed and inject coolant (LLC-10) into vehicle.
 - Reconnect the Service Interlock Connector (A)
 - Use the GDS under Actuation Test to manually turn on EWP to aid in air bleeding during coolant injection.

NOTE

- **Coolant concentration (coolant: diluted water): 6:4**
- **Coolant injection: 1.9 liters (coolant + diluted water)**
- **If there is a large amount of low-conductivity coolant (blue) remaining inside the vehicle, the color of the newly injected pink coolant may change to murky. In this case, drain all coolant inside the vehicle and re-inject normal (pink) coolant.**

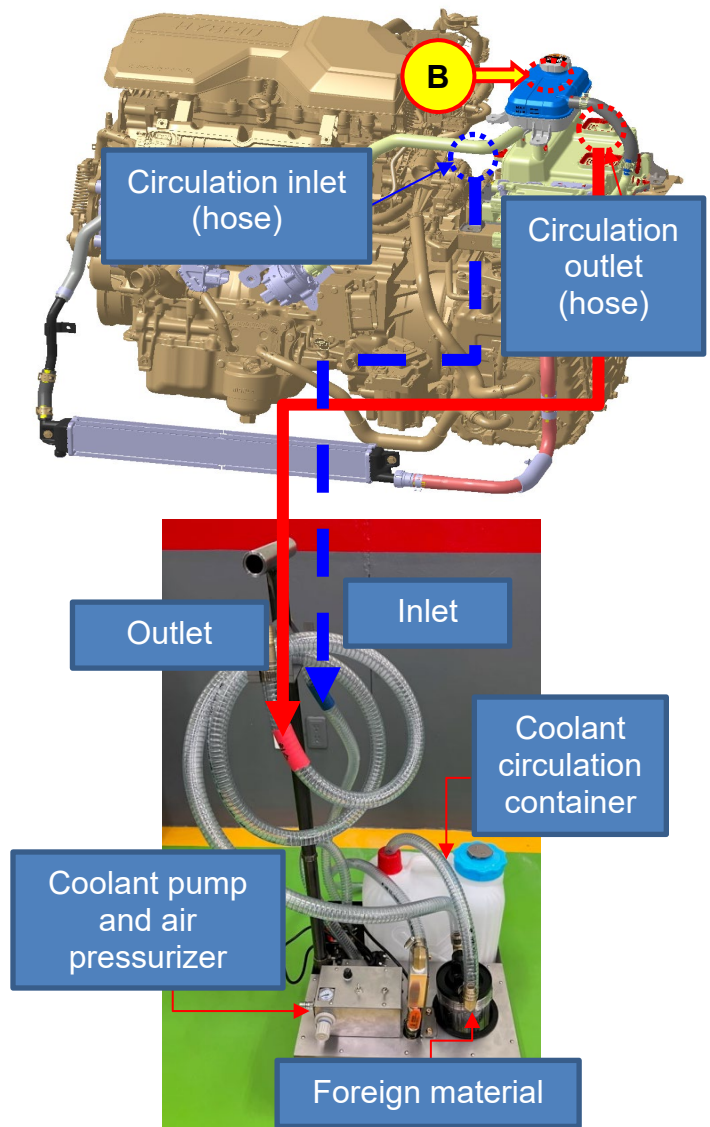

13. Replace the inverter reservoir tank cap label.
 - Use a cutter knife to remove the old label and affix the new label.

14. Turn the vehicle on into “Ready” mode and confirm that the phrase “Coolant supplement” is not shown on the cluster.
 - If the message is shown, repeat the flush procedure starting from Step 1.
 - If the message is not shown, proceed to the next step.

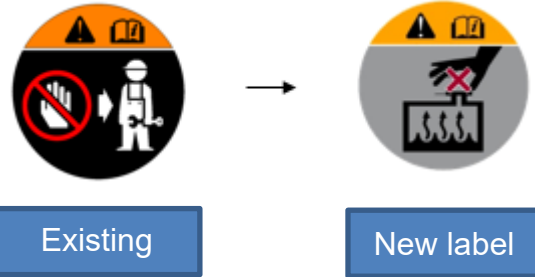

15. Clean the filter & filter case of the equipment with the air gun to remove foreign substances.

- Ensure to remove as much of the foreign substances as possible.
- A poorly cleaned filter can result in decreased flow rate and degrade the cleaning effect of the cleaning machine.
- Sludge can get stuck to the inner wall of the filter case, be sure to clean the filter evenly.

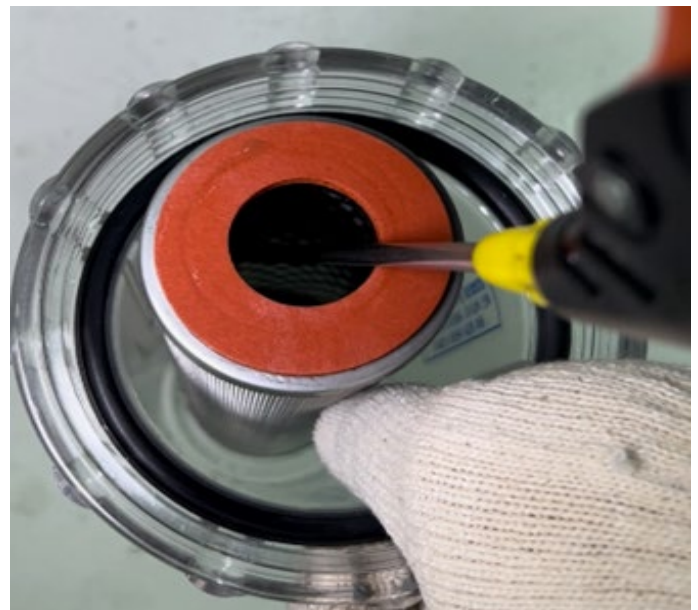

16.

STUI

Using STUI, photograph the reservoir showing Pink LLC-10 Coolant along with the last 6 digits of the VIN and the date of the repair on a piece of paper.

Upload the photo to STUI.

17. End of Service Procedure.

