

06/13/2023
CAL FTL 54-030

Subject: Bendix BlindSpotter Sensor Installation

**Models Affected: New Cascadia and Business Class M2 vehicles
built June 1, 2022 to the present.**

Our records indicate that you are the owner of certain vehicles and therefore DTNA has decided to share the following documentation with you.

Certain New Cascadia and Business Class M2 vehicles wired for Bendix BlindSpotter, specified with 73K-001 datacode, were shipped without having the sensor installed. Follow the work instructions to install the BlindSpotter sensor.

NOTE: For M2 Chassis, DTNA Custom Truck Services installs the BlindSpotter sensor. The work instructions can only be used as a rough guideline for the sensor installation.

Please see the attached communication in this email. We hope you find this information helpful.

06/13/2023
CAL FTL 54-030

Special Tools Required

A torque wrench capable of measuring 19±1 lbf·in (215±11 N·cm), provided with a 3/8-inch socket.

Parts Required for New Cascadia

Part Number	Part Description	Quantity
A06-96260-000 (Bendix K184743R000)	BlindSpotter sensor	1
06-86118-000 OR A06-85830-000	Bracket - fairing mount (only for aerodynamic fairings) OR Bracket - step mount (only for side steps without fairings)	1*
23-11609-720	Torx screw - stainless, #10-24 x 2 inch - pan head	3*
23-10900-014	Washer - #10 x 0.75 OD, stainless flat	3*
23-09336-005	Shoulder nut - #10-24 zinc-plated steel nylon self-locking	3 [#]
23-09796-309	Tie strap - 8-inch long x 0.190-inch wide, black	As required

* If not already present on the vehicle.

Replacement is recommended even if the nut is already present.

Although a stainless steel nylon self-locking shoulder nut can be used, this combination requires use of an appropriate anti-seize lubricant such as Loctite® LB 8150, Jet-Lube® Kopr-Kote, Permatex® Copper, or similar lubricants, to prevent seizing and galling of the screw or nut threads.

Parts Required for Business Class M2

Part Number	Part Description	Quantity
A06-96260-000 (Bendix K184743R000)	BlindSpotter sensor	1
23-11609-720	Torx screw - stainless, #10-24 x 2 inch - pan head	3*
23-10900-014	Washer - #10 x 0.75 OD, stainless flat	3*
23-09336-005	Shoulder nut - #10-24 zinc-plated steel nylon self-locking	3 [#]
23-09796-309	Tie strap - 8-inch long x 0.190-inch wide, black	As required

* If not already present on the vehicle.

Replacement is recommended even if the nut is already present.

Although a stainless steel nylon self-locking shoulder nut can be used, this combination requires use of an appropriate anti-seize lubricant such as Loctite® LB 8150, Jet-Lube® Kopr-Kote, Permatex® Copper, or similar lubricants, to prevent seizing and galling of the screw or nut threads.

06/13/2023
CAL FTL 54-030

Work Instructions

1. Park the vehicle on a level surface, shut down the engine, and set the parking brake. Chock the tires.
2. Locate the two chassis harness connectors for the BlindSpotter sensor. Connector location may vary depending on the vehicle options. Some examples of harness routings are shown in [Fig. 1](#), [Fig. 2](#), and [Fig. 3](#).

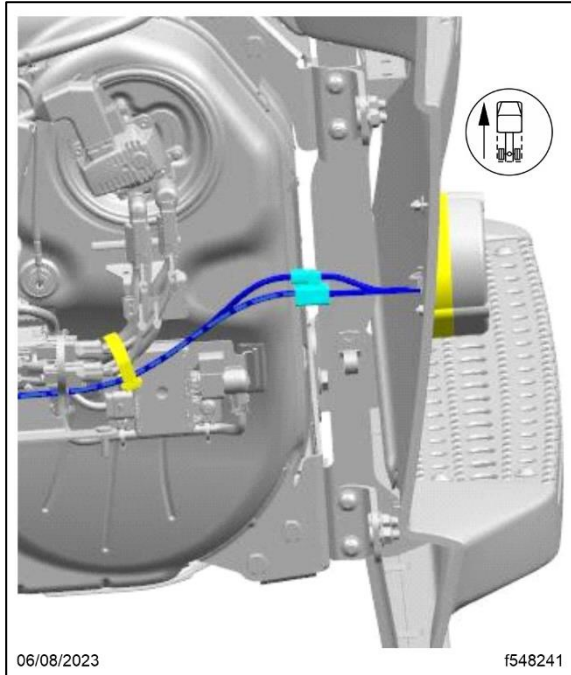

Fig. 1, New Cascadia Harness Routing Behind the Aftertreatment Device (ATD)

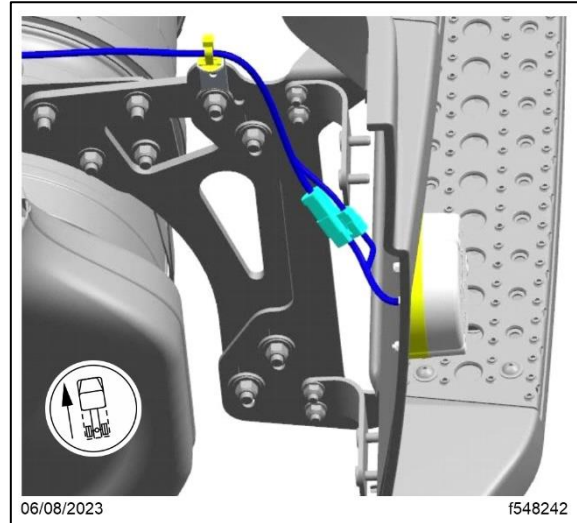

Fig. 2, New Cascadia Harness Routing Along Top of the Fairing Mounting Bracket

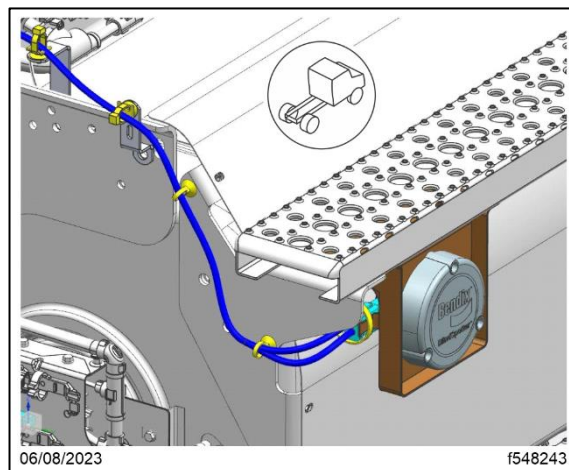

Fig. 3, New Cascadia Harness Routing with Steps

06/13/2023
CAL FTL 54-030

3. Pass the connectors through the hole in the fairing or mounting bracket. If necessary, loosen or remove the tie straps to allow the connectors to reach the hole in the mounting bracket. See [Fig. 4](#).
 - If the BlindSpotter sensor is being mounted on an aerodynamic fairing, the harness connectors must pass through both the fairing and the mounting bracket (06-86118-000). Failure to correctly install the mounting bracket (06-86116-000) will cause the sensor to be pointed at the ground, which will result in a reduced effectiveness of the BlindSpotter system.
4. Connect the two harness connectors on the BlindSpotter sensor to the harness connectors.
5. Push the connectors and wiring harness back through the mounting bracket or fairing, until the BlindSpotter sensor is flush with the mounting bracket.
 - For fairing-mounted sensors, rotate the bracket (06-86118-000) so that the taller part of the bracket is at the bottom. See [Fig. 5](#).



Fig. 4, Business Class M2 Harness Routing

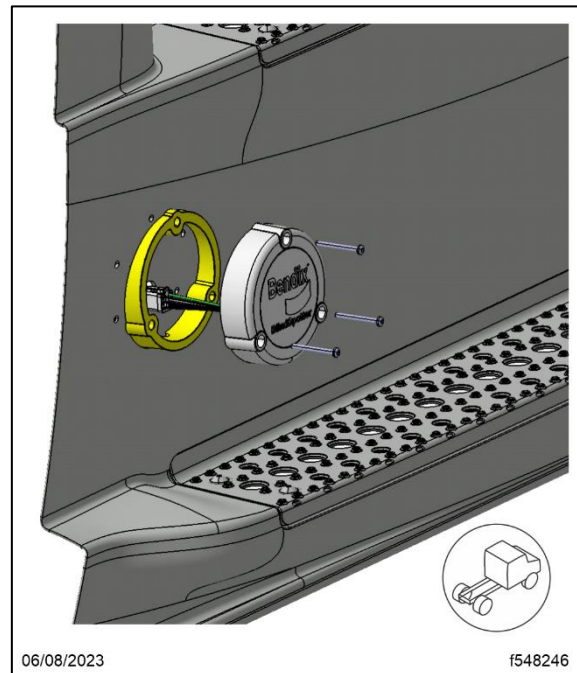

Fig. 5, Sensor Mounting on Fairing

06/13/2023

CAL FTL 54-030

- Align the sensor to the mounting holes, then install three #10-24 screws through the sensor. On the back of the fairing or mounting bracket, install a flat washer and a #10-24 nylon self-locking nut, as shown in **Fig. 6**. Tighten the nut 18 to 20 lbf·in (203 to 226 N·cm). Do not over-tighten the nut. See **Fig. 7**.

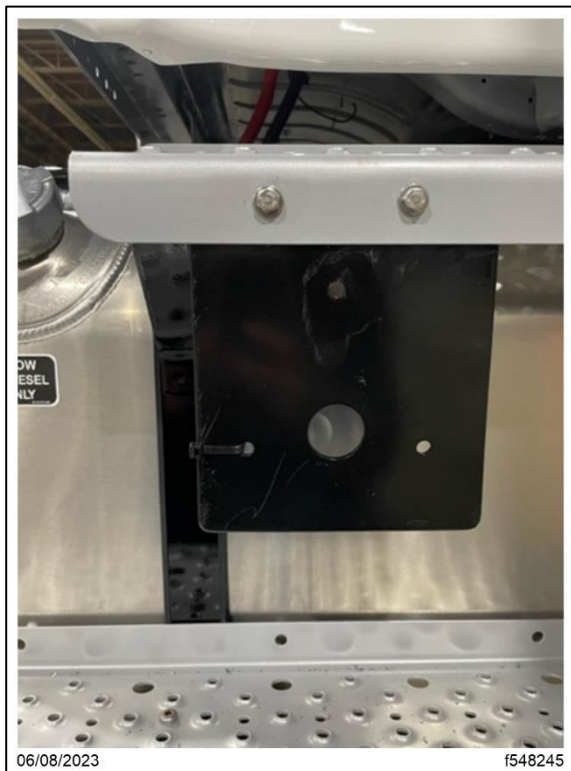

Fig. 6, Step Mounting Bracket Showing Hole for Harness Routing

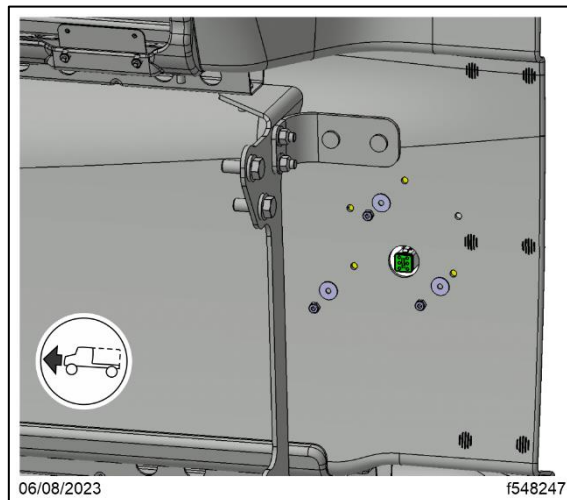

Fig. 7, Washer and Locknut Installation

- If the tie straps were removed in step 3, use new tie straps to secure the harness connector.
- Turn the ignition key to the ON position, but do not start the engine.
- Wait for 30 seconds to allow the BlindSpotter to complete its automatic baud rate configuration.
- Turn the ignition key to the OFF position.