



Service Action

Code: 40S9

Subject Suspension Strut Mountings

Document History

Date	Summary
June 07, 2023	Original publication

Affected Vehicles

Country	Beginning Model Year	Ending Model Year	Vehicle	Vehicle Count
USA	2023	2023	GOLF GTI	52
USA	2023	2023	GOLF R	7
CAN	2023	2023	GOLF GTI	11
CAN	2023	2023	GOLF R	3

Check Campaigns/Actions screen in ELSA on the day of repair to verify that a VIN qualifies for repair under this action. ELSA is the only valid campaign inquiry & verification source.

- ✓ Campaign status must show "open."
- ✓ If ELSA shows other open action(s), inform your customer so that the work can also be completed at the same time the vehicle is in the workshop for this campaign.

Problem Description

During strut assembly, an issue may have caused a deformation of the strut mount. If the strut mount is deformed, it can lead to improper torque on one of the bolted connections on the right or left suspension strut mounting.

Corrective Action

Inspect and, if necessary, replace the right and/or left suspension strut mounting(s).

Code Visibility

On or about June 07, 2023, the campaign code will be applied to affected vehicles.

Owner Notification

Owner notification will take place in June 2023. Owner letter examples are included in this bulletin for your reference.

Campaign Expiration Date

This campaign expires on **December 31, 2028**. Repairs must be performed on or before this date to be eligible for payment. Keep this expiration date in mind when scheduling customers for this action. If a customer wishes to have this service performed after the expiration date, your dealerships normal parts and labor cost associated with this repair will apply.

Additional Information

Please alert everyone in your dealership about this action, including Sales, Service, Parts and Accounting personnel. Contact Warranty if you have any questions.

Dealers must ensure that every affected inventory vehicle has this campaign completed before delivery to consumers.

Fill out and affix Campaign Completion Label (CAMP 010 000) after work is complete. Labels can be ordered at no cost via the Compliance Label Ordering portal at www.vw.com.

Parts Information

Parts Control Type:
Free Order Parts will be managed by Free Order

Initial Allocation:
NO There will be no parts allocation. Please reference the Repair Projection Tool (below) to view your potential VIN population.

Repair Projection Tool:
(right click to open) 

The following parts are needed for all vehicles in order to perform the strut mount inspection:

Criteria	Quantity	Part Number	P.O.C. Part Description	Ordering Method
01 OR 02	1	N -912-464-01	BOLT	Free Order
01 AND 02	2			

The following parts are needed only if a strut mount requires replacement:

Criteria	Quantity	Part Number	P.O.C. Part Description	Ordering Method
ALL	1 per strut mount	5Q0-412-331-E	MOUNTING	Free Order
	2 per strut mount	N -015-081-6	NUT	
	1 per strut mount	N -101-064-02	NUT	
	1 per strut mount	N -102-058-02	NUT	
	3 per strut mount	N -103-320-02	NUT	
	1 per strut mount	N -909-548-02	BOLT	
	1 per strut mount	N -910-216-01	NUT	
	3 per strut mount	N -912-464-01	BOLT	
	1 per strut mount	WHT-005-437-A	12POINT S	

NOTE

The specified part numbers reflect the status at the start of this action. Interim updates made in ETKA can cause a listed part number to become unavailable. In this case, the new part number specified in ETKA should be used.

Claim Entry Instructions

The labor times listed here may differ from the labor operations and labor times listed in ELSA.

After campaign has been completed, enter claim as soon as possible to help prevent work from being duplicated elsewhere. Attach the ELSA screen print showing action open on the day of repair to the repair order.

If customer refused campaign work:

- ✓ U.S. dealers: Submit request via WISE under the *Campaigns/Update/Recall Closure* option.
- ✓ Canada dealers: Upload the repair order [signed by customer] to Volkswagen WIN/Operations/Campaign Closure.

Service Number	40S9		
Damage Code	0099		
Parts Vendor Code	WVO		
Claim Type	Sold vehicle: 7 10 Unsold vehicle: 7 90		
Causal Indicator	Mark labor as causal if strut mount(s) are ok. Mark MOUNTING* as causal part if strut mount(s) require replacement.		
Vehicle Wash/Loaner	Do not claim wash/loaner under this action U.S.A.: Loaner/rental coverage cannot be claimed under this action. However, loaner/rental may be covered under the Alternate Transportation Program. Please refer to the Volkswagen Warranty Policy and Procedures Manual for loaner claims information and reimbursement details. Canada: Loaner/rental coverage cannot be claimed under this action. Please refer to Volkswagen Service Loaner Program to determine loaner eligibility.		
Vehicles may have more than one criteria. Complete and claim all applicable criteria on <u>one</u> claim.			
Criteria I.D.	01 or 02		
	LABOR		
	Labor Op	Time Units	Description
	4088 01 99	70	Check 1 front suspension strut mounting for deformation
	PARTS		
	Quantity	Part Number	Description
	1.00	N 91246401	BOLT

Continued on next page

Criteria I.D.	01 and 02		
	LABOR		
	Labor Op	Time Units	Description
	4088 02 99	75	Check 2 front suspension strut mounts for deformation.
	PARTS		
	Quantity	Part Number	Description
	2.00	N 91246401	BOLT

AND (only if necessary)	Add if strut mount(s) require replacement		
Criteria I.D.	01 02 01 and 02		
	LABOR		
	Labor Op	Time Units	Description
	4088 55 99	120	Replace 1 strut mount
	OR		
	4088 56 99	240	Replace 2 strut mounts
	PARTS		
	Quantity	Part Number	Description
	Up to 2.00	5Q0412331E	MOUNTING*
	Up to 4.00	N 0150816	SHOULDERED HEX. NUT
	Up to 2.00	N 10106402	SHOULDERED HEX. NUT, SELF-LOCKING
	Up to 2.00	N 10205802	OVAL HEXAGON SOCKET HEAD BOLT
	Up to 6.00	N 10332002	SHOULDERED HEX. NUT
	Up to 2.00	N 90954802	OVAL HEXAGON SOCKET HEAD BOLT
	Up to 2.00	N 91021601	SHOULDERED HEX. NUT
	Up to 4.00	N 91246401	BOLT
Up to 2.00	WHT005437A	12POINT S	

Customer Letter Example (USA)

<MONTH YEAR>

<CUSTOMER NAME>

<CUSTOMER ADDRESS>

<CUSTOMER CITY STATE ZIPCODE>

This notice applies to your vehicle: <MODEL YEAR> <BRAND> <CARLINE>, <VIN>

Subject: Service Action 40S9 - Suspension Strut Mountings

Dear Volkswagen Owner,

As part of Volkswagen's ongoing commitment to customer satisfaction, we are informing you of our decision to conduct a service action on certain 2023 model year Volkswagen vehicles. Our records show that you are the owner of a vehicle affected by this action.

What is the issue? During strut assembly, an issue may have caused a deformation of the strut mount. If the strut mount is deformed, it can lead to improper torque on one of the bolted connections on the right or left suspension strut mounting.

What will we do? Your authorized Volkswagen dealer will inspect and, if necessary, replace the right and/or left suspension strut mounting(s). This work may take about 4 hours to complete and will be performed for you free of charge. Please keep in mind that your dealer may need additional time for the preparation of the repair, as well as to accommodate their daily workshop schedule.

What should you do? Please contact your authorized Volkswagen dealer as soon as possible to schedule this service. To set up an appointment online, please visit www.vw.com/find-a-dealer.

This service action will be available for you **free of charge only until December 31, 2028**. If you wish to have this service performed after that date, your dealer's normal costs associated with this repair will apply.

Lease vehicles and address changes If you are the lessor and registered owner of the vehicle identified in this action, please forward this letter immediately via first-class mail to the lessee within ten (10) days of receipt. If you have changed your address or sold the vehicle, please fill out the enclosed prepaid Owner Reply card and mail it to us so we can update our records.

Can we assist you further? If your authorized Volkswagen dealer fails or is unable to complete this work free of charge within a reasonable time, or if you should have any questions about this communication, please reach out to us using your preferred method of communication at www.vw.com/contact or by calling us at 800-893-5298.

Checking your vehicle for open Recalls and Service Campaigns To check your vehicle's eligibility for repair under this or any other recall/service campaign, please visit www.vw.com/owners/recalls and enter your Vehicle Identification Number (VIN) into the Recall/Service Campaign Lookup tool.

We apologize for any inconvenience this matter may cause; however we are taking this action to help ensure your vehicle continues to meet and exceed your expectations.

Sincerely,

Volkswagen Customer Protection

Customer Letter Example (CANADA)

<MONTH YEAR>

<CUSTOMER NAME>

<CUSTOMER ADDRESS>

<CUSTOMER CITY STATE ZIPCODE>

This notice applies to your vehicle: <MODEL YEAR> <BRAND> <CARLINE>, <VIN>

Subject: Service Action 40S9 - Suspension Strut Mountings

Dear Volkswagen Owner,

As part of Volkswagen's ongoing commitment to customer satisfaction, we are informing you of our decision to conduct a service action on certain 2023 model year Volkswagen vehicles. Our records show that you are the owner of a vehicle affected by this action.

What is the issue? During strut assembly, an issue may have caused a deformation of the strut mount. If the strut mount is deformed, it can lead to improper torque on one of the bolted connections on the right or left suspension strut mounting.

What will we do? Your authorized Volkswagen dealer will inspect and, if necessary, replace the right and/or left suspension strut mounting(s). This work may take about 4 hours to complete and will be performed for you free of charge. Please keep in mind that your dealer may need additional time for the preparation of the repair, as well as to accommodate their daily workshop schedule.

What should you do? In order to limit any possible inconvenience, please contact your authorized Volkswagen dealer as soon as possible to schedule this service. Please keep in mind that your dealer may need additional time for the preparation of the repair, as well as to accommodate their daily workshop schedule.

This service action will be available for you free of charge only until December 31, 2028. If you wish to have this service performed after that date, your dealer's normal costs associated with this repair will apply.

Lease vehicles and address changes If you are the lessor and registered owner of the vehicle identified in this action, please forward this letter immediately via first-class mail to the lessee within ten (10) days of receipt. If you have changed your address or sold the vehicle, please fill out the enclosed prepaid Owner Reply card and mail it to us so we can update our records.

Can we assist you further? If your authorized Volkswagen dealer fails or is unable to complete this work free of charge within a reasonable time, please contact Customer Relations, Monday through Friday from 8AM to 8PM EST by phone at 1-800-822-8987 or via our "Contact Us" page at www.vw.ca.

We apologize for any inconvenience this matter may cause; however we are taking this action to help ensure your vehicle continues to meet and exceed your expectations.

Sincerely,

Volkswagen Customer Protection

Repair Overview

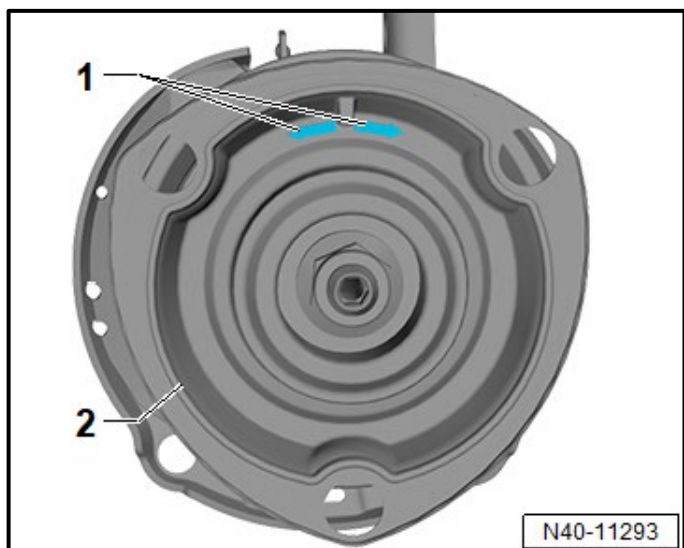

Criteria 01 vehicles:

- Check suspension strut mounting for deformation, front left.

Criteria 02 vehicles:

- Check suspension strut mounting for deformation, front right.

Criteria 01 and 02 vehicles:

- Check suspension strut mounting for deformation, front left and right.

NOTE

- These repair instructions may differ from the labor operations and labor times listed in ELSA.
- Damages resulting from improper repair or failure to follow these work instructions are the dealer's responsibility and are not eligible for reimbursement under this action.
- This procedure must be read in its entirety prior to performing the repair.
- Due to variations in vehicle equipment and options, the steps/illustrations in this work procedure may not identically match all affected vehicles.
- Diagnosis and repair of pre-existing conditions in the vehicle are not covered under this action.
- When working during extreme temperatures, it is recommended that the vehicle be allowed to acclimate inside the shop to avoid temperature-related component damage/breakage.

Repair Instruction

Section A - Check for Previous Repair

TIP

If Campaign Completion label is present, no further work is required.

Applicable criteria ID(s)	Campaign/Action Status
01 	Open 

EXAMPLE

Campaign/Action	Start	Designation
	2015-11-10	W-SERV_ACT -
	2018-12-13	RECALL -
	2017-05-16	A-RECALL -

EXAMPLE

- Enter the VIN in Elsa and proceed to the “Campaign/Action” screen.

TIP

On the date of repair, print this screen and keep a copy with the repair order.

- Confirm the Campaign/Action is open <arrow 1>. If the status is closed, no further work is required.
- Note the Applicable Criteria ID <arrow 2> for use in determining the correct work to be done and corresponding parts associated.

CRITICAL REPAIR STEP



If multiple software update Campaign/Actions are open, they must be performed in order of the Start date <arrow 3>. The oldest should be performed first.

- **All Safety Recalls must be completed prior to completing this campaign.**
- **Proceed to section B.**

Section B – Check Suspension Strut Mounting for Deformation

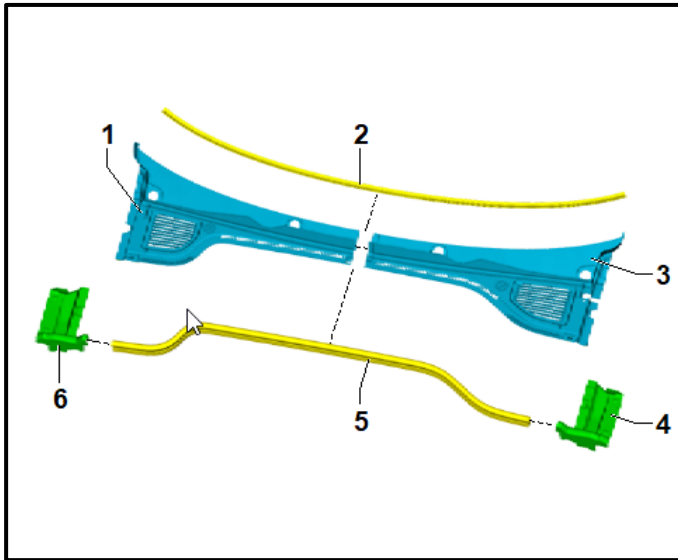

All vehicles:

- Remove under hood plenum chamber cover according to the ELSA repair manual.
 - See ELSA Repair Manual: *Repair manual > Body > 50 Body Front > Bulkhead > Plenum Chamber Cover, Removing and Installing.*

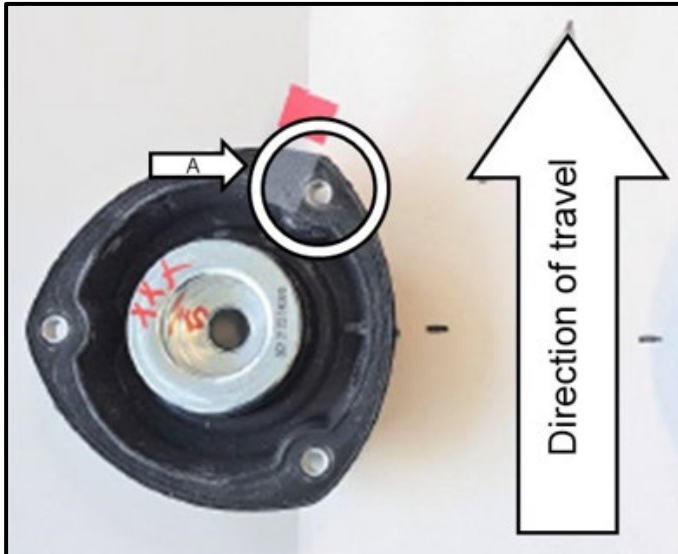

Criteria 01 and 01 + 02 vehicles, left front strut mount inspection:

- Remove the bolt <arrow A> at the front of the left strut mount in the direction of travel.

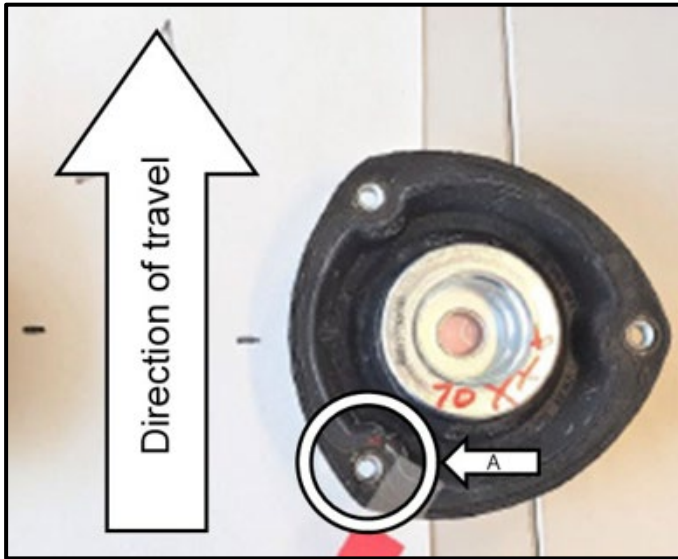

Criteria 02 and 01 + 02 vehicles, right front strut mount inspection:

- Remove the bolt <arrow A> at the rear of the right strut mount in the direction of travel.

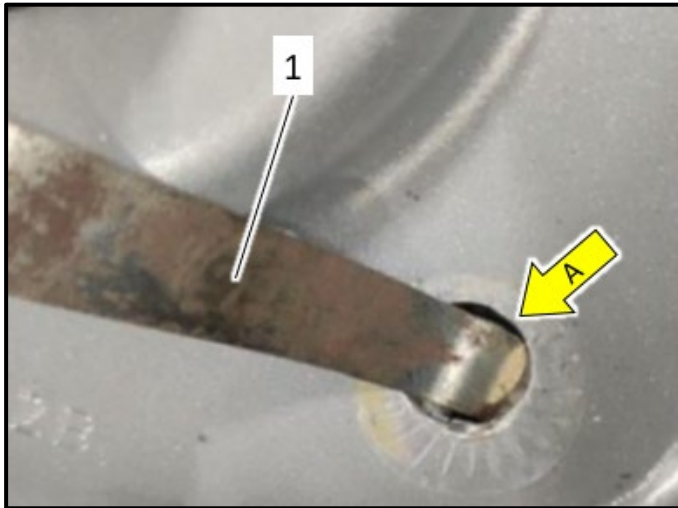

All vehicles continued:

- Using a 0.05mm (0.002") feeler gauge <1>, check if there is a gap between the strut mount(s) and the body <arrow A>.
- If a gap is detected:
 - The strut mount requires replacement
 - **Proceed to Section C.**
- If there is not a gap detected, install a new bolt and torque to 20 Nm + 90°.

Part Number	Part Description
N 912 464 01	Bolt

- If the strut mount(s) are OK:
 - Reinstall the plenum chamber cover in the reverse order of removal.
 - **Proceed to Section D.**

Section C – Replacement of Deformed Strut Mount(s)

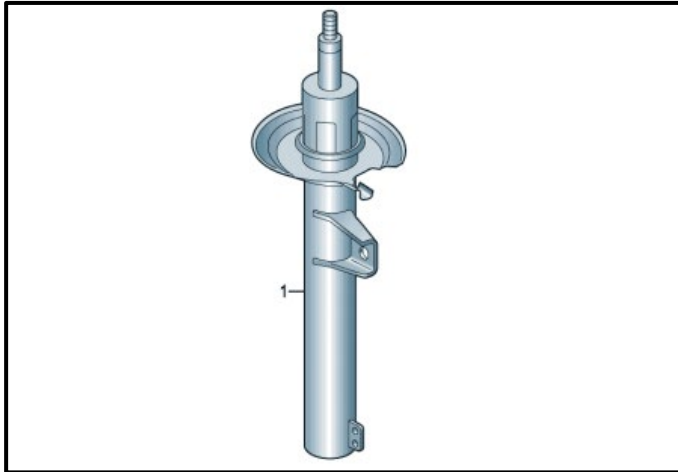

Remove the affected strut(s):

- Remove the affected strut(s) from the vehicle according to the ELSA repair manual:
 - See ELSA Repair Manual: *Repair Manual > Chassis > Suspension, Wheels, and Steering, 40 Front Suspension > Suspension Strut and Upper Control Arm > Suspension Strut, Removing and Installing.*

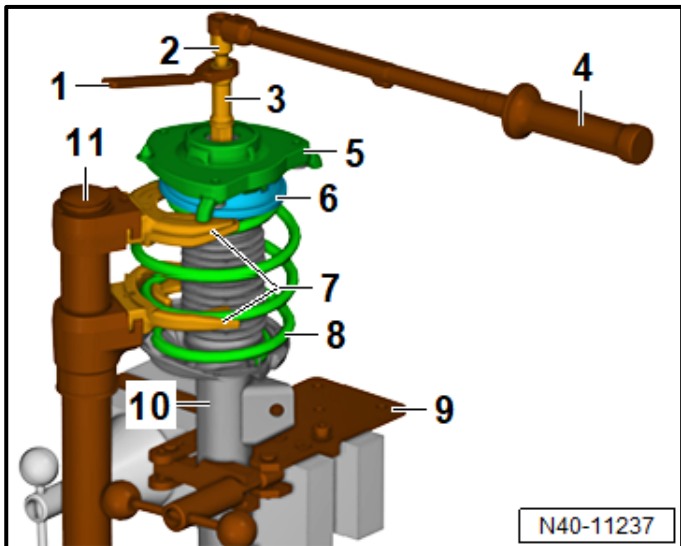

Replace the deformed strut mount(s):

CAUTION

Incorrectly pre-tensioning the spring increases the risk of injury! Components are under tension and loosening the threaded connection can lead to injury!

- Make sure the spring is positioned correctly in the spring compressor.
 - Pretension the spring, until the strut mount is released.
- Replace the affected strut mount(s) according to the ELSA repair manual:
 - See ELSA Repair Manual: *Repair Manual > Chassis > Suspension, Wheels, and Steering, 40 Front Suspension > Suspension Strut and Upper Control Arm > Spring, Removing and installing.*

Proceed to Section D

Section D – Campaign Completion Label

Install Campaign Completion Label

- Fill out and affix Campaign Completion Label, part number CAMP 010 000, next to the vehicle emission control information label.



TIP

Ensure Campaign Completion Label does not cover any existing label(s).

Proceed to Section E

Section E - Parts Return/Disposal

Properly store (retain), destroy or dispose of removed parts in accordance with all state/province and local requirements, unless otherwise indicated and/or requested through the Warranty Parts Portal (WPP) for U.S. and the Part Destruction and Core Disposition Report for Canada.