

Technical Service Bulletin



91 Parking aid sensor bracket(s) separates from rear bumper

91 23 05 2068573/2 June 12, 2023. Supersedes Technical Service Bulletin Group 91 number 22-52 dated December 1, 2022, for reasons listed below.

| Model(s) | Year | VIN Range | Vehicle-Specific Equipment |
|-------------------|-------------|-----------|----------------------------|
| All Audi Vehicles | 2019 – 2024 | All | Not Applicable |

Condition

| REVISION HISTORY | | |
|------------------|------------|---|
| Revision | Date | Purpose |
| 2 | - | Revised header (Included all current models 2019 -2024) Revised Parts and Tools (Adjusted epoxy quantity to 1 and removed mixing nozzle) |
| 1 | 12/01/2022 | Initial publication |

Customer states:

The rear parking aid sensor provides false warnings, is missing from the rear bumper, or a warning is displayed for the rear parking aid system.

Workshop findings:

The retaining plate for the parking sensor has come loose from the rear apron.

Technical Background



The adhesive strength of the parking aid bracket is not sufficient.

Over time, one or more of the sensor mounts may separate from the rear apron.



Figure 1: The parking aid mount has come loose.

It is possible for the parking aid sensor(s) to issue false warnings when the mounts start to separate.

For a customer concern relating to false detection of obstacles it is important to check each of the sensors on the rear apron for correct installation.



Figure 2: The parking aid mount has come loose.



Production Solution

Optimized process during production.

Service

If one or more of the sensor brackets has come loose from the rear bumper, use the steps below to re-attach the mounts.



Note: If the mount is missing or damaged the rear apron will need to be replaced.

Prep work:

- Remove the rear bumper cover according to the repair manual.



Note: If multiple brackets are loose, ensure each bracket stays in the same position. Each mount needs to be re-bonded in the same position and orientation to the rear apron.

- Remove the old adhesive tape from bonding surfaces of the rear apron and affected brackets.
- Lightly sand/scuff the bonding surfaces of the apron and mount(s).
- Clean the rear apron and mount(s) thoroughly with plastic cleaner **D 009 401 04** or equivalent (isopropyl alcohol) and allow to dry for 5 minutes.
- Apply a thin coating of primer for plastic components **D 822 150 A1** to rear apron and bracket, allow to dry for 10 minutes.
- Prepare all affected brackets up to this step prior to bonding.



Tool Setup:

- Special tool **VAS 6614/C** will be used to complete this repair.
- Inside there are 3 sets of holders in various diameters to accommodate different size PDC sensors.
- Use the appropriately sized holder to center and clamp the mounts.



Figure 3: VAS 6614/C contents.



- Slide parking aid bracket -6- onto centering pin -3- (VAS 6614) and push through rear apron -7- as seen in Figure 4.
- Slide on counter hold tool -2- from outside and tighten knurled nut slightly.
- Align bracket -6- in correct position and according to markings on rear apron.
- Slide on clamp -4- and screw in knurled nut -5- but do not tighten yet.

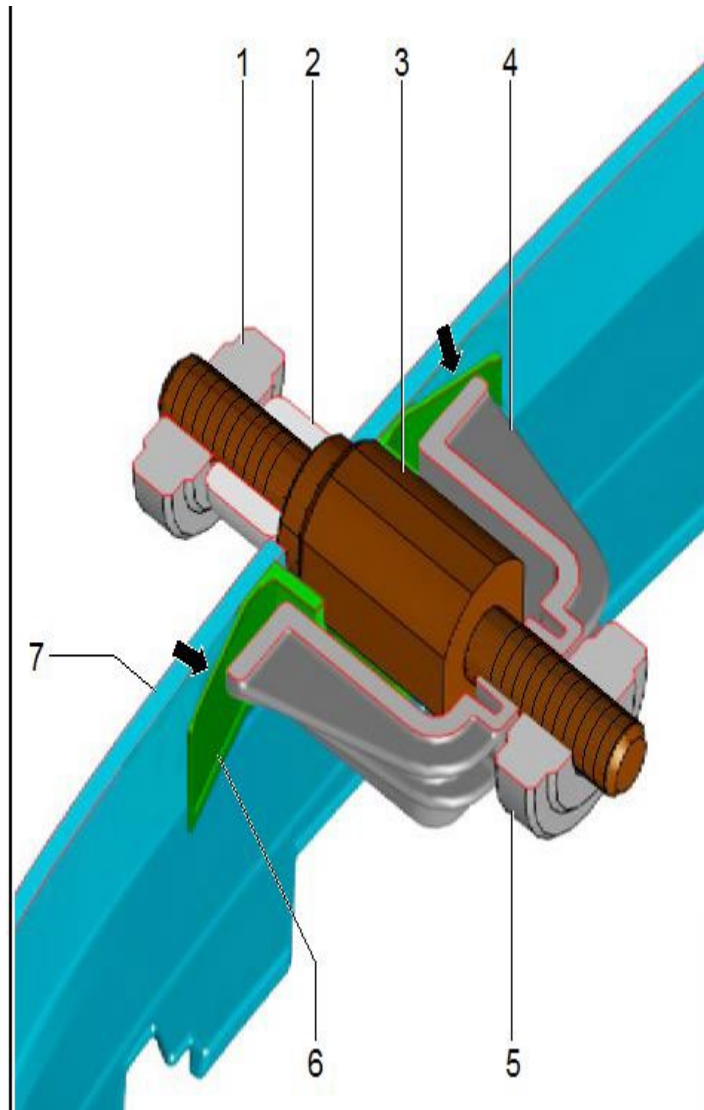
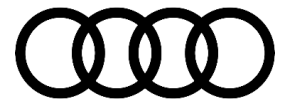

Figure 4: VAS 6614 assembled with PDC mount on rear apron.



Bonding the mount(s):

Apply plastic adhesive **D 180 KU2 A1** to areas marked by arrows between the parking aid bracket and rear apron (Figure 5).

- The first 3-5 cm of adhesive from the mixing nozzle may not be properly mixed and must therefore be discarded.

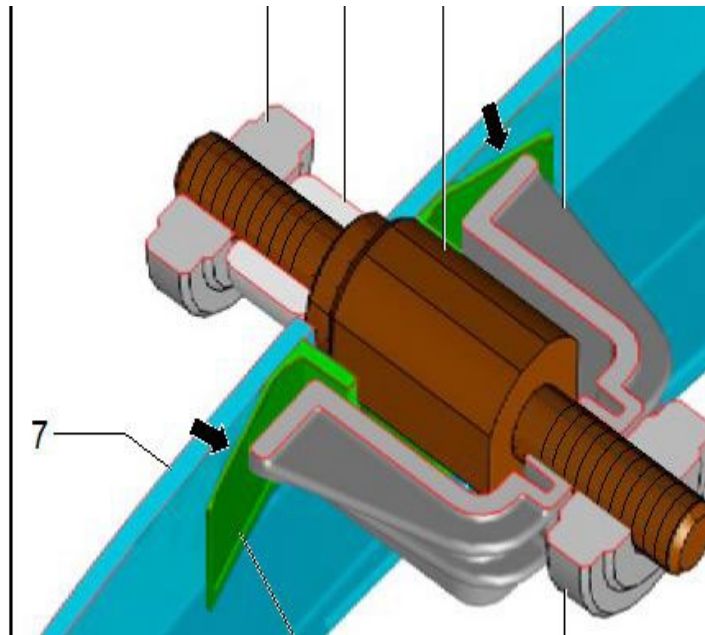

Figure 5: Arrows mark location for adhesive.

- Tighten knurled nut -3-.
- This results in clamp -2- pushing tabs of bracket -4- flat onto rear apron/spoiler -5-.
- Perform this step for all affected brackets.

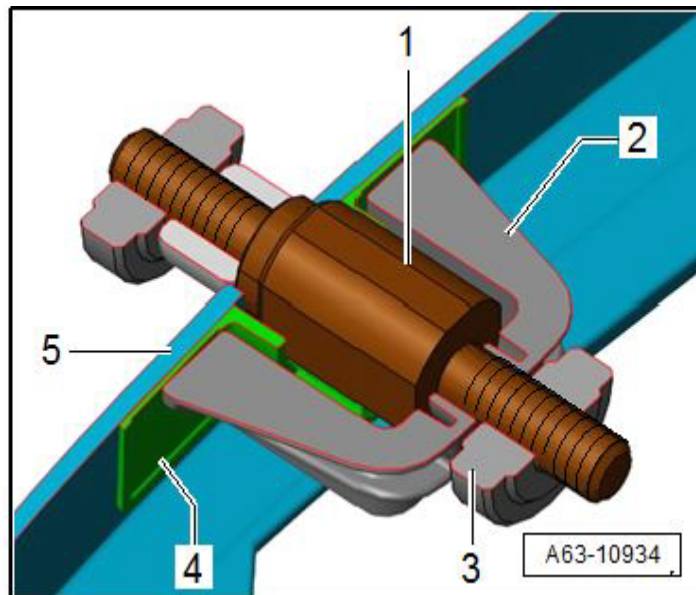
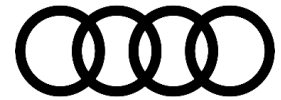

Figure 6: Mounts compressed to spoiler.

- Allow a minimum drying time of 30 minutes before removing the jig.
- The rear apron must be left undisturbed during this period and must not be moved.
- Re-Install the rear bumper cover and confirm system operation.

Technical Service Bulletin



Warranty

| | | | |
|--------------------------|--|--------------|--|
| Claim Type: | <ul style="list-style-type: none"> • 110 Up to 48 Months/50,000 Miles. • G10 for CPO Covered vehicles – Verify Owner. • If the vehicle is outside of any warranty, this Technical Service Bulletin is informational only. | | |
| Service Number: | 9175 | | |
| Damage Code: | 0018 | | |
| Labor Operations: | Remove and install rear bumper cover | 6369 19xx | See SRT with associated operations |
| | Re-attach 1 sensor bracket | 9175 4999 | 50 TU |
| | Re-attach each additional sensor bracket (up to 3) | 9175 5099 | 20 TU (max 60 TU) |
| Diagnostic Time: | GFF | 0150 0000 | Time stated on the diagnostic protocol (Max 50 TU) |
| | Road test prior to the service procedure | No allowance | 0 TU |
| | Road test after the service procedure | No allowance | 0 TU |
| Claim Comment: | As per TSB 2068573/2 | | |

All warranty claims submitted for payment must be in accordance with the *Audi Warranty Policies and Procedures Manual*. Claims are subject to review or audit by Audi Warranty.

Required Parts and Tools

| The part numbers mentioned in this TSB are different from the ones listed in ETKA. Only use parts listed in this TSB, this includes superseding part numbers! | | |
|---|--|---------------|
| Part Number | Part Description | Quantity |
| See ETKA | Fasteners, Bolts, Nuts, and Screws as needed per the Repair Manual | See ETKA/ELSA |
| D180KU2A1 | Plastic adhesive | 1 |
| D822150A1 | Primer | 0.1 |



| | | |
|------------|---|-----|
| D 00940104 | Plastic cleaner or equivalent (isopropyl alcohol) | 0.1 |
|------------|---|-----|

| Tool Number | Tool Description |
|-------------------|--|
| VAS 6614C | PDC holder tool set |
| VAS 5155 | Hand cartridge gun |
| VAS 6160/VAS 6150 | VAS tester with the current version of ODIS (Windows 10) |

Additional Information

All parts and service references provided in this TSB (2068573) are subject to change and/or removal.

©2023 Audi of America, Inc. All rights reserved. The information contained in this document is based on the latest information available at the time of printing and is subject to the copyright and other intellectual property rights of Audi of America, Inc., its affiliated companies, and its licensors. All rights are reserved to make changes at any time without notice. No part of this document may be reproduced, stored in a retrieval system, or transmitted in any form or by any means, electronic, mechanical, photocopying, recording, or otherwise, nor may these materials be modified or reposted to other sites, without the prior expressed written permission of the publisher.