



## STAR ONLINE PUBLICATION



**Case Number:** S2308000049

**Release Date:** April 2023

**Symptom/Vehicle Issue:** Center Console End Cap USB Port Inoperative

**Customer Complaint/Technician Observation:** Rear center console USB port does not operate.

**Repair Procedure:** Test the rear port operation by using multiple test USB cables to confirm the issue is not cable related. If the concern is not related to a cable issue, remove the center console rear end cap to inspect the harness connection to the USB port prior to any component replacement Fig 1, 2 and 3.



This document does not authorize warranty repairs. This communication documents a record of past experiences. STAR Online does not provide any conclusions about what is wrong with the vehicle. Rather, it captures all previous cases known that appear to be similar or related to the vehicle symptom / condition. You are the expert, and you are responsible for deciding on the appropriate course of action.4.17.21

**Contact STAR Center, or your Technical Assistance Center Via TechCONNECT or eCONTACT ticket if no solution is found**



## STAR ONLINE PUBLICATION



### FLOOR CONSOLE END CAP REMOVAL

1. Remove the fastener covers and remove the fasteners from the rear cup holder.

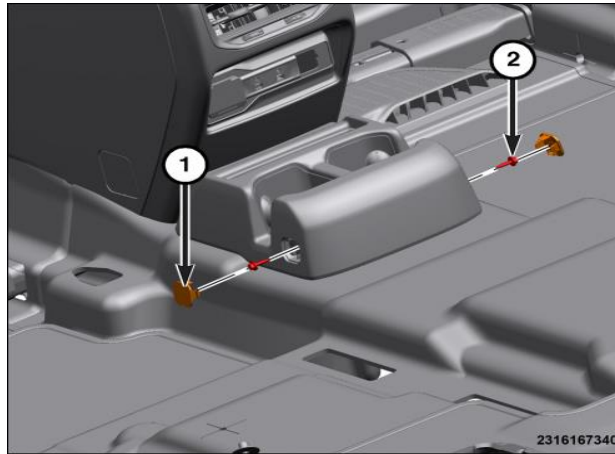

1 - Fastener Cover

2 - Fastener

2. Lift up and back and remove the rear cup holder from the vehicle.

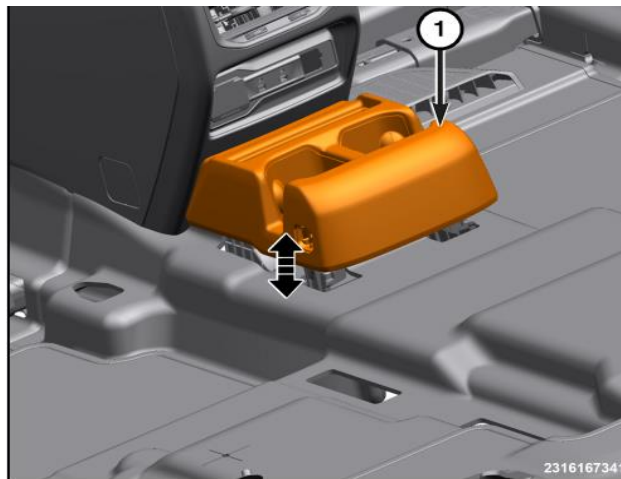

1 - Rear Cup Holder

**Fig 1**

This document does not authorize warranty repairs. This communication documents a record of past experiences. STAR Online does not provide any conclusions about what is wrong with the vehicle. Rather, it captures all previous cases known that appear to be similar or related to the vehicle symptom / condition. You are the expert, and you are responsible for deciding on the appropriate course of action.4.17.21

**Contact STAR Center, or your Technical Assistance Center Via TechCONNECT or eCONTACT ticket if no solution is found**



## STAR ONLINE PUBLICATION



3. Using a trim stick or equivalent, release the front floor console armrest hinge cover.

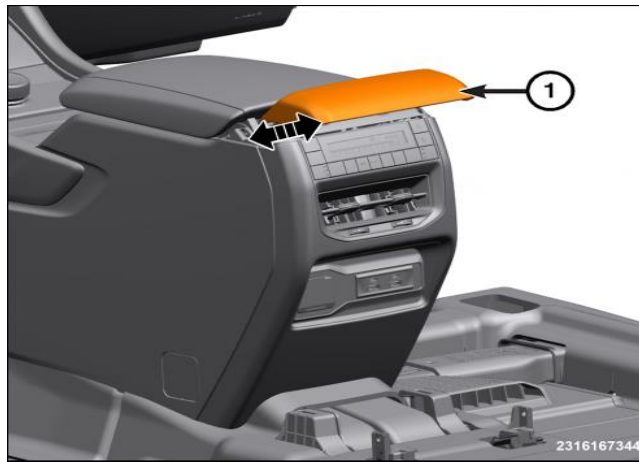

1 - Front Floor Console Armrest Hinge Cover

4. Remove the fasteners from the floor console end cap.

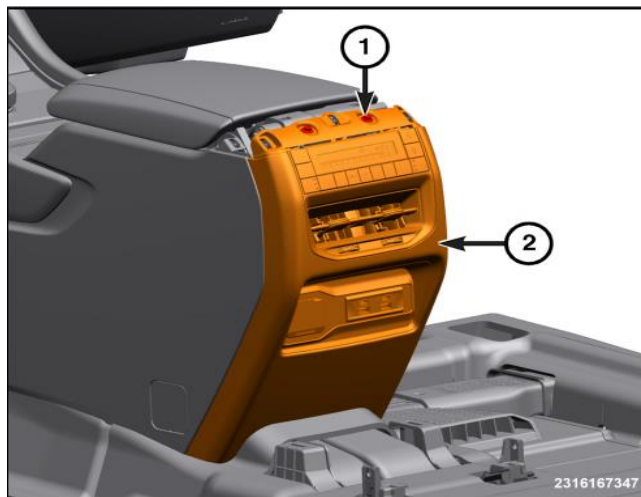

1 - Fastener

2 - Floor Console End Cap

**Fig 2**

This document does not authorize warranty repairs. This communication documents a record of past experiences. STAR Online does not provide any conclusions about what is wrong with the vehicle. Rather, it captures all previous cases known that appear to be similar or related to the vehicle symptom / condition. You are the expert, and you are responsible for deciding on the appropriate course of action.4.17.21

**Contact STAR Center, or your Technical Assistance Center Via TechCONNECT or eCONTACT ticket if no solution is found**



## STAR ONLINE PUBLICATION



5. Using a trim stick or equivalent, release the floor console end cap from the floor console.
6. Separate end cap from the floor console and inspect the rear USB harness connector, secure the connector using the push, pull, push method.



**Fig 3**

This document does not authorize warranty repairs. This communication documents a record of past experiences. STAR Online does not provide any conclusions about what is wrong with the vehicle. Rather, it captures all previous cases known that appear to be similar or related to the vehicle symptom / condition. You are the expert, and you are responsible for deciding on the appropriate course of action.4.17.21

**Contact STAR Center, or your Technical Assistance Center Via TechCONNECT or eCONTACT ticket if no solution is found**