



Service Bulletin

Bulletin No.: 16-NA-405

Date: May, 2023

TECHNICAL

Subject: Poor Engine Performance in Extremely Cold Weather Conditions, PCV Bypass Hose and Charge Air Cooler Icing for LUV Engines, Malfunction Indicator Lamp (MIL) Illuminated - DTC P0299, P0234, P2227, P00C7 Set

Attention: For vehicles that are out of warranty and are identified on the Applicable Warranties section in the GM Global Warranty Management system, refer to Special Coverage #17157 or A192272980.

Brand:	Model:	Model Year:		VIN:		Engine:	Transmission:
		from	to	from	to		
Buick	Encore	2013	2021	Refer to Parts Information section for breakpoints.		1.4L (RPO LUV)	—
Chevrolet	Trax						

Involved Region or Country	North America
Condition	<p>Some customers may comment that when driving in extremely cold weather conditions (-18°C or less / 0°F or less), their vehicle experiences one or several of the following conditions:</p> <ul style="list-style-type: none"> • Loss of power. • Smoke out the tail pipe. • Hesitation on acceleration. • Stalling condition. • Burning oil odor possibly caused by oil leak. • May also notice a Malfunction Indicator Lamp illuminated. • After driving for a period of time, the driveability issues seem to diminish. • Malfunction Indicator Lamp (MIL) illuminated. <p>This condition may also cause an increase in crankcase pressure, creating oil leaks at seals and gaskets.</p> <p>The technician may find one or more of the following DTCs set:</p> <ul style="list-style-type: none"> • P0299 • P0234 • P2227 • P00C7
Cause	<p>This condition may be caused by one or more of the following:</p> <ul style="list-style-type: none"> • Plugged crank case vent tube from ice forming in the tube during very cold weather conditions. • Ice accumulating in the intake manifold forming and blocking the PCV passage in the cylinder head. • Ice accumulation in the charge air cooler, restricting air flow to the throttle body.

<p>Correction</p>	<p>Important: The PCV heater parts are only to be used in northern states or provinces where temperatures are -18°C or less / 0°F or less and for critical customers only.</p> <p>Important: The DTCs and symptoms above are not exclusively related to freezing/icing conditions. Only follow this bulletin when the condition is directly correlated with extreme cold of -18°C or less / 0°F or less. System leaks should always be ruled out first for P0299. Signs of moisture will always be present in the CAC system and are not a reliable indicator of freezing/icing.</p> <p>Note: U.S. vehicles are NOT built with the revised CAC or heated PCV bypass system. To determine which CAC is installed in the vehicle, refer to Charge Air Cooler Outlet Air Elbow Duct Replacement below.</p> <p>If any of the conditions are validated to be caused by freezing/icing, verification of the following components is necessary on all U.S. and Canadian vehicles:</p> <ul style="list-style-type: none"> • Grille Winter Cover • Heated PCV Bypass system • Modified Charge Air Cooler (CAC) • Elbow Duct <p>If not previously performed, install either the grille cover, heated PCV bypass, CAC or elbow duct.</p> <p>If the vehicle has a verified icing condition associated with extreme cold, but has all the components listed above installed, perform the Intake Air Pressure and Temperature Sensor Inspection and Cleaning procedure and CAC drain procedure below.</p> <p>If not previously performed, an oil change may be necessary to remove any moisture from the engine. Prior to the oil change, warm the engine up completely to melt any ice in the engine.</p> <p>Note: It is not recommended to clean or flush the intake manifold or bypass solenoid.</p> <p>If contamination (Ice/water/oil/sludge) at the charge air bypass valve is found, refer to Service Bulletin # 22-NA-067 for intake replacement.</p>
--------------------------	--

Important: Allow time for the vehicle to thaw in a warm environment to avoid damaging or breaking parts that may be required to be re-installed.

Grille Winter Cover Installation

Warning: Remove the grille cover when temperatures are consistently above 32°F/ 0°C to prevent engine and transmission overheating. Remove the grille cover before towing a trailer of any size. Failure to do so will decrease transmission cooling efficiency and possibly cause damage to the drivetrain.

Note: The cover may appear to be undersized. The vinyl used may stretch during installation to ensure a tight fit. It is highly recommended to warm the vinyl cover so that it can be pliable enough to install onto the front bumper fascia.

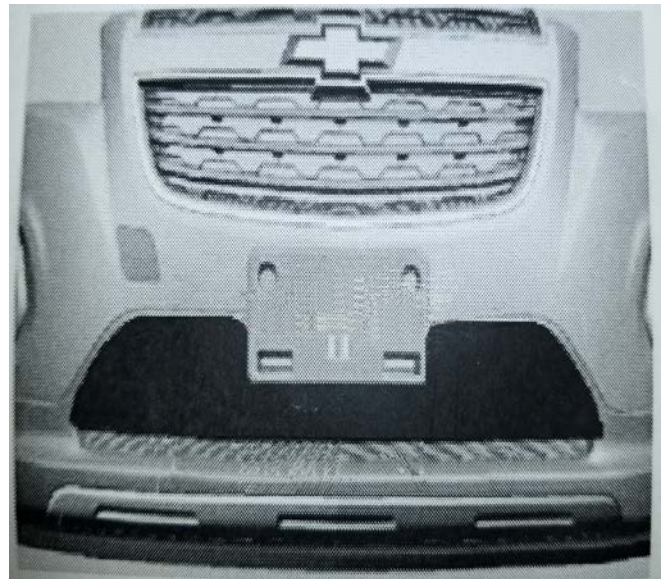

5197596

1. Using care, orientate the fascia winter cover to the bumper fascia.

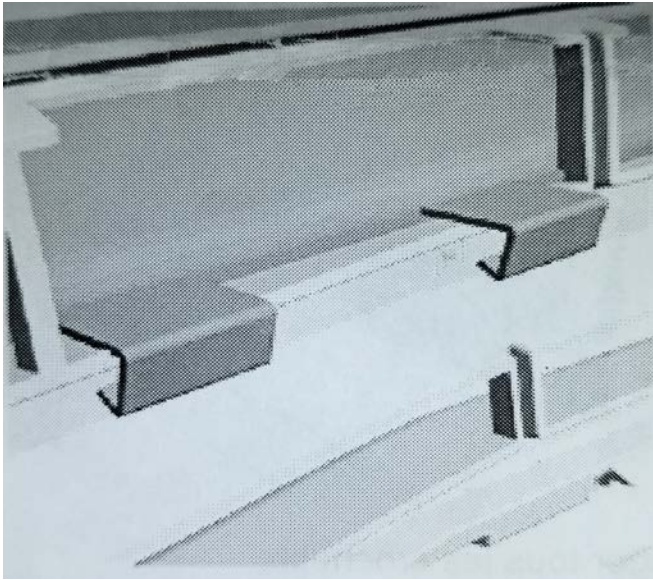

5193266

2. Attach the cover to the fascia by pushing the hooks through the grille openings.
3. Validate that all the hooks are engaged and the cover is a tight fit.

Intake Manifold and Cylinder Head Inspection

Refer to Service Bulletin # 22-NA-067.

Charge Air Cooler Outlet Air Elbow Duct Replacement



5236304

Important: If this vehicle has the CAC outlet tube P/N 42698921 installed on the vehicle, replace the air duct with the **NEW** kit part number 42751703.

Important: If the kit part number 42751703 is not available, the dealer can order a new CAC outlet hose part number 42731155.

1. Remove the charge air cooler outlet air hose. Refer to *Charge Air Cooler Outlet Air Hose Replacement* in SI.

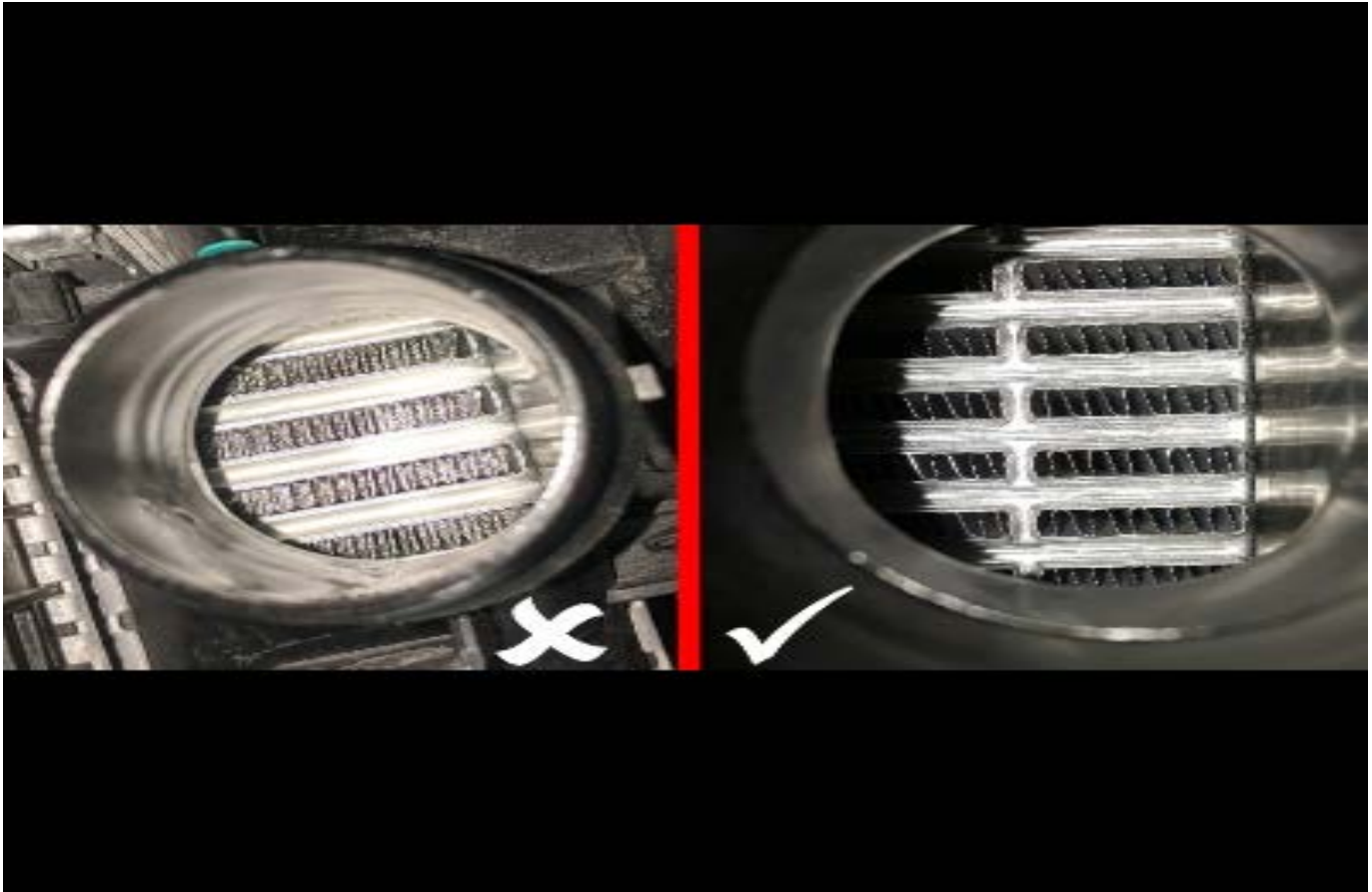

6159510

2. Inspect the charge air cooler through the inlet to determine if the vehicle has the new or old design.
 - If the charge air cooler is the old design (shown by X in the graphic), proceed to the Charge Air Cooler Replacement section below.
 - If the charge air cooler is the new design (shown by the check mark in the graphic – note the wider fin spacing and a division in the middle of the charge air cooler), no charge air cooler replacement is necessary.
3. Remove and clean the IAPT sensor.
4. Using care, remove the bands that secure the air hoses to the elbow duct.



5410152

Note: The new elbow duct will have an estimated 45 degree mounting surface for the IAPT.

5. Install the new elbow duct onto the air hoses aligning the duct to the marks.
6. Install the band clamps.
7. Install the IAPT sensor.
8. Install the charge air cooler outlet air hose.

Intake Air Pressure and Temperature Sensor Inspection and Cleaning

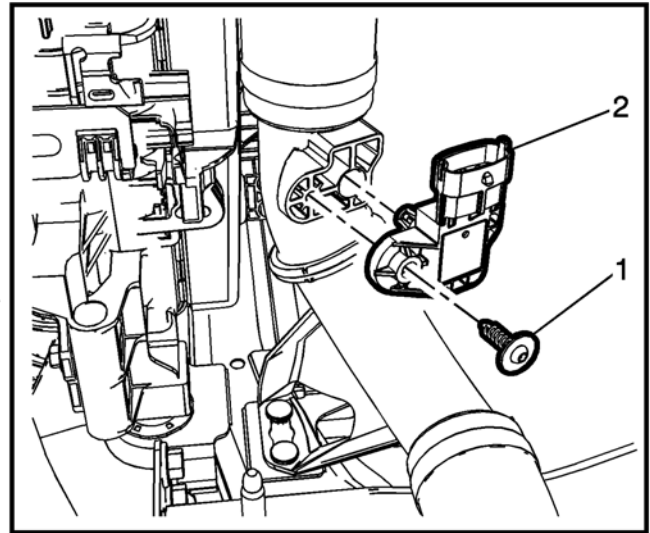
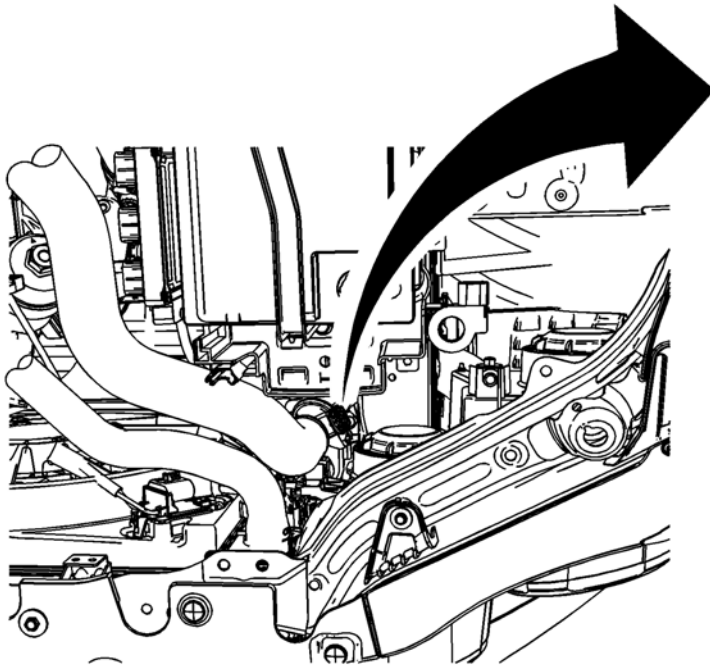

1. If necessary, remove the intake air pressure and temperature (IAPT) sensor (2). Refer to *Intake Air Temperature Sensor Replacement in SI*.

4910635



4910683

Important: Due to the sensitivity of the IAPT, **Do Not** use any chemical cleaners including water and **Do Not** use compressed air to remove contaminants.

2. Inspect the IAPT sensor for any contaminants.

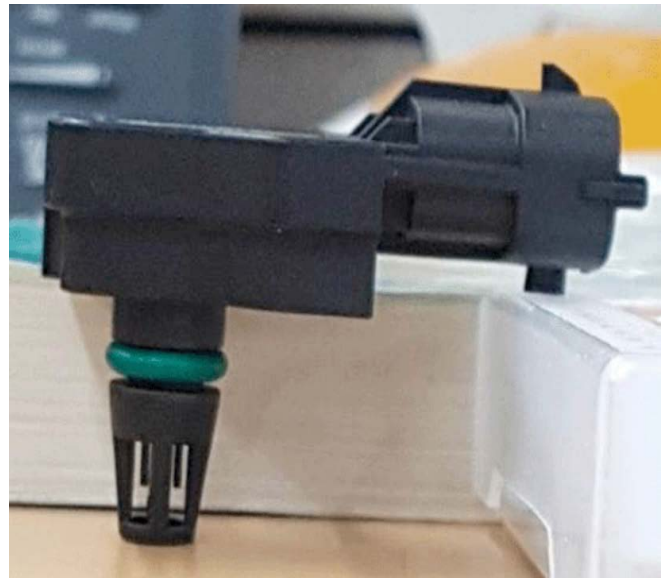

5020216

3. Allow time for any ice build-up to melt by placing the sensor port down.
4. Clean the sensor with a clean towel.
5. Inspect the IAPT sensor for any contaminants.
6. Install the sensor into the elbow duct.

PCV Heater Installation

Notice: The PCV heater may have been installed previously onto the vehicle. If the PCV heater has been installed, proceed to step 35.

1. Operate the vehicle until it reaches operating temperature.
2. Remove the battery. Refer to *Battery Replacement* in SI.
3. Remove the engine cover.

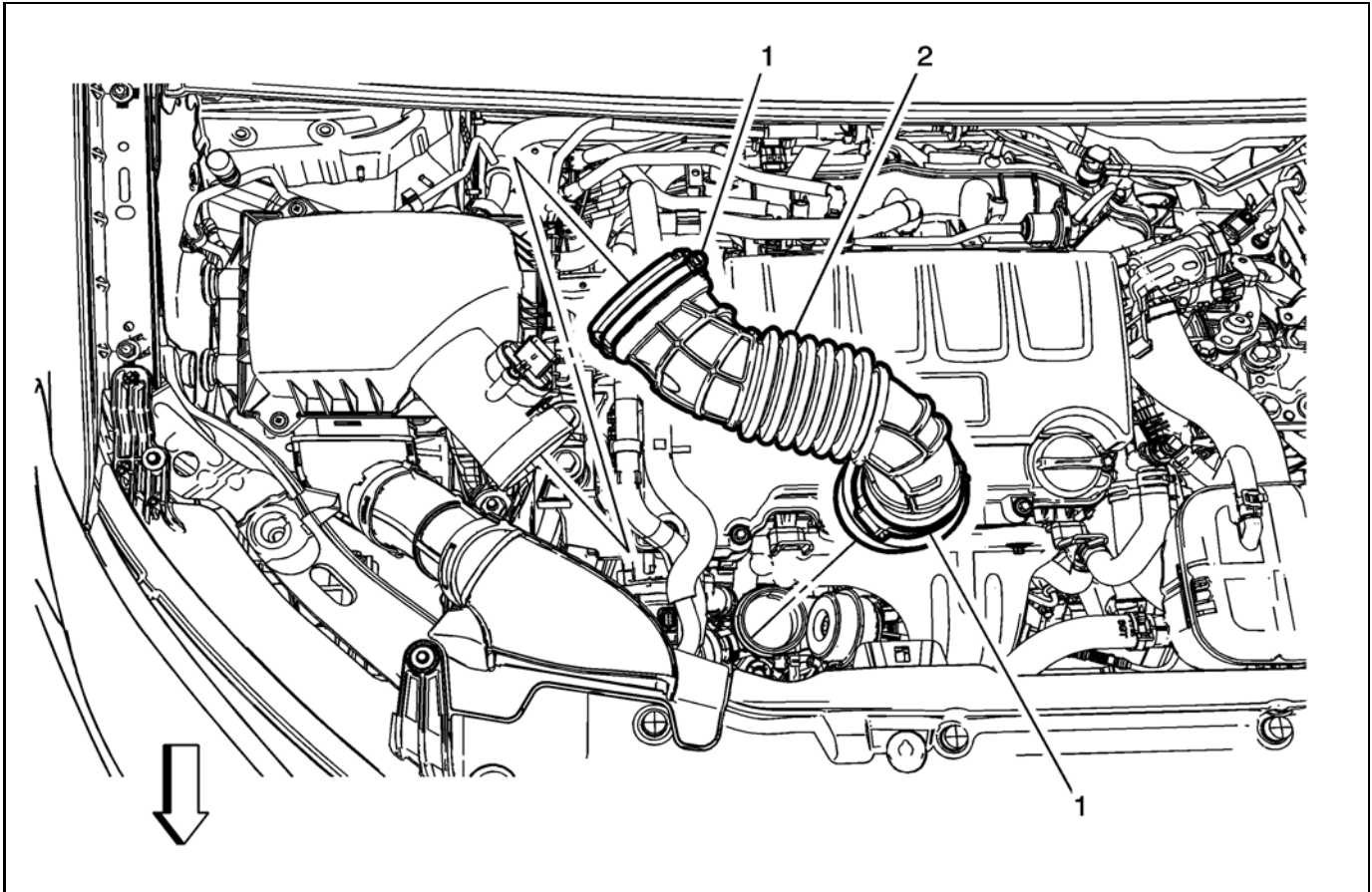

4. Remove and discard the air cleaner outlet duct (2) and resonator assembly.

Caution: DO NOT remove the vacuum hose from the engine unless the vacuum hose shows apparent signs of damage. Damage to the nipple on the intake manifold may occur when attempting to disconnect the vacuum hose.

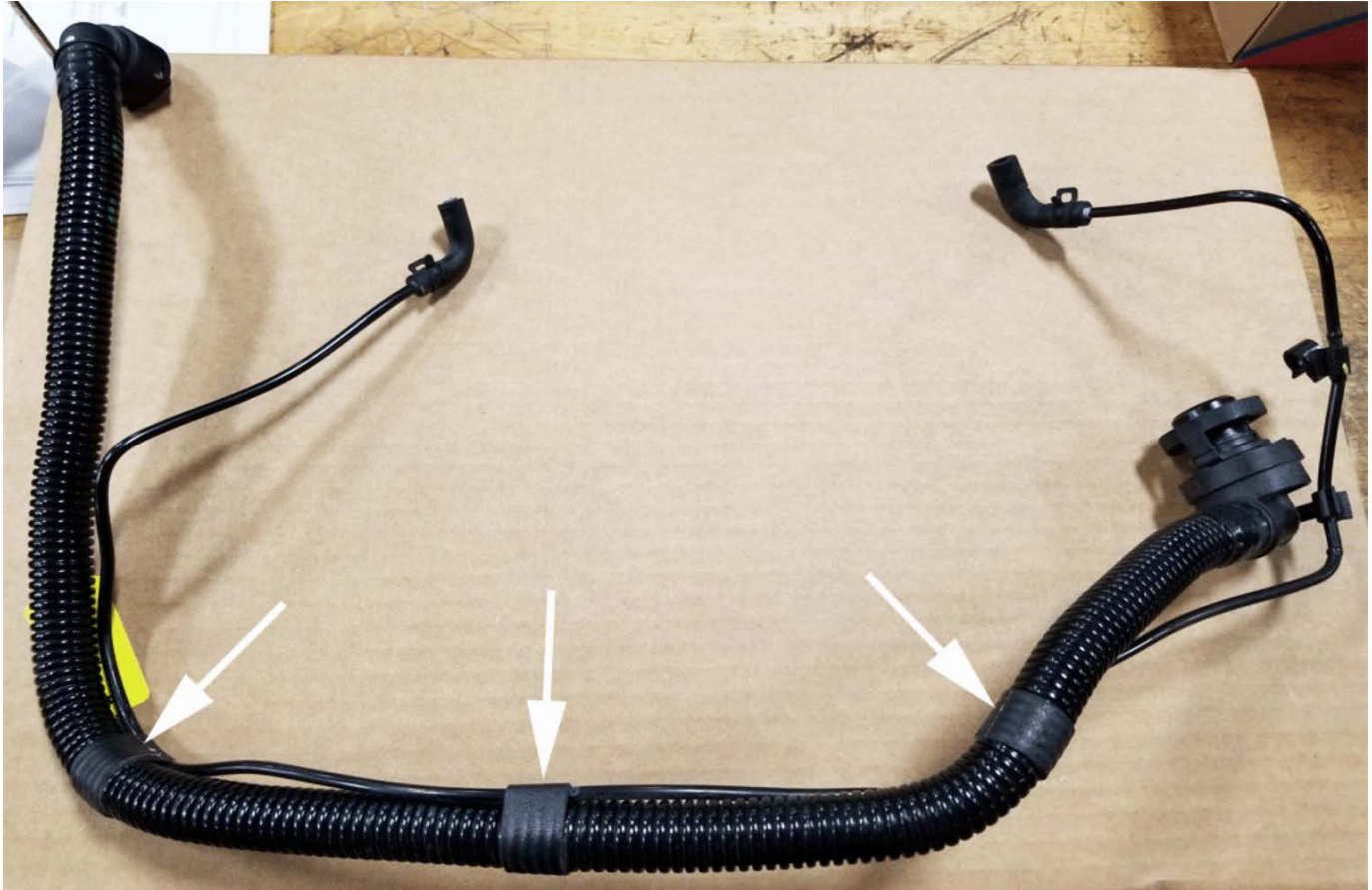

4855374

5. Using care, cut and remove the tape that secures the vacuum line to the positive crankcase ventilation (PCV) hose/pipe/tube.

Note: Original PCV pipe with vacuum line attached removed from vehicle for illustrative purposes **ONLY**.

6. Remove and discard the PCV hose/pipe/tube (1) leaving the vacuum line. Refer to *Positive Crankcase Ventilation Hose/Pipe/Tube Replacement* in SI.

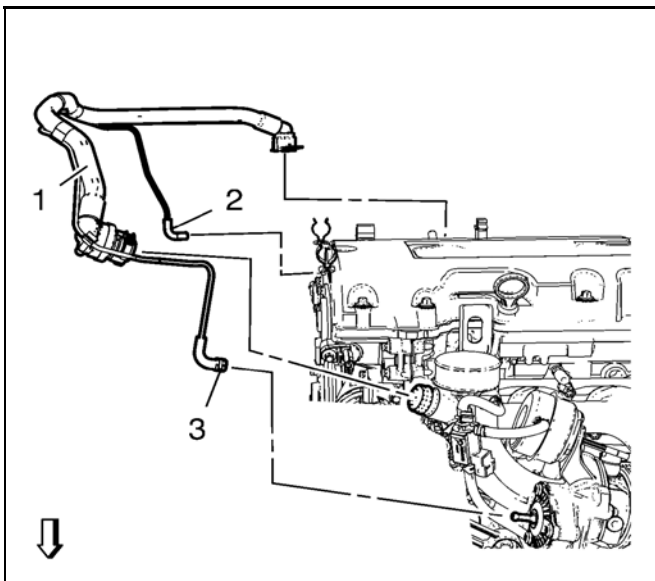

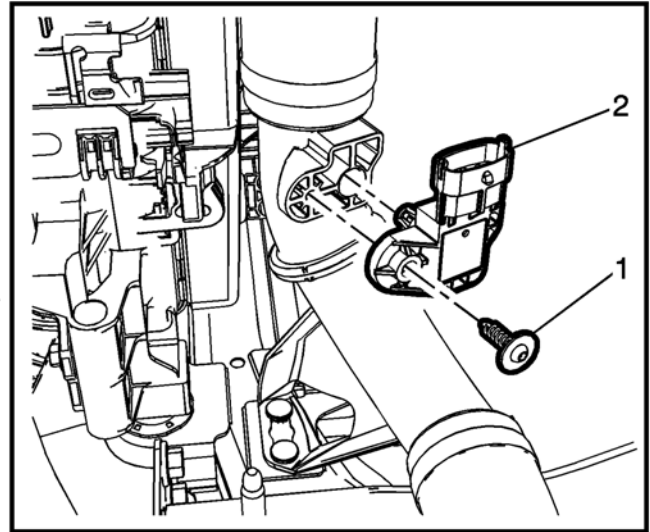
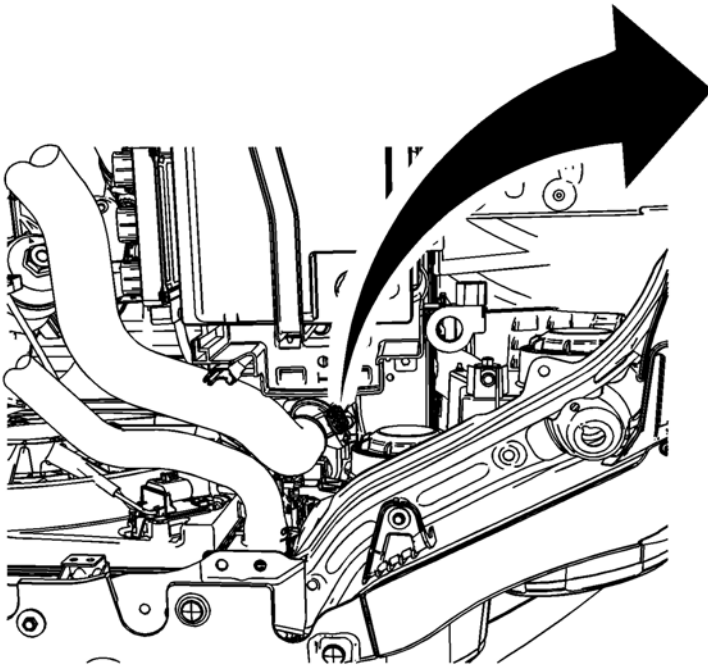

7. If necessary, remove the intake air pressure and temperature (IAPT) sensor (2). Refer to *Intake Air Pressure and Temperature Sensor Replacement* in SI.

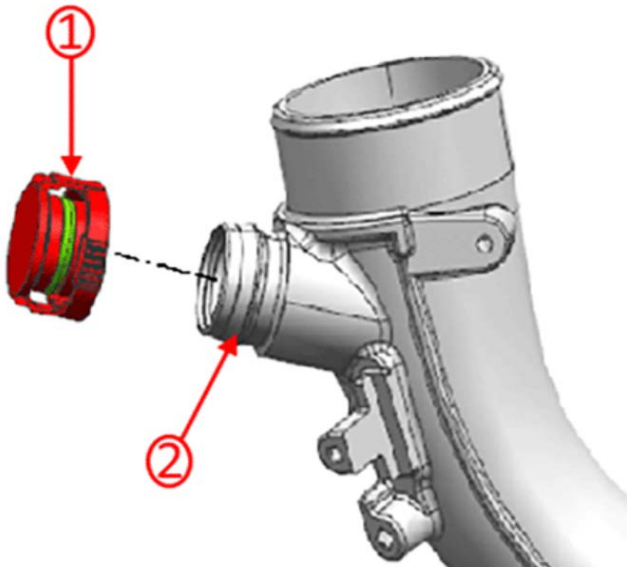

4377828

8. Install the block off plug (1) onto the turbocharger PCV bypass port (2).

4910635

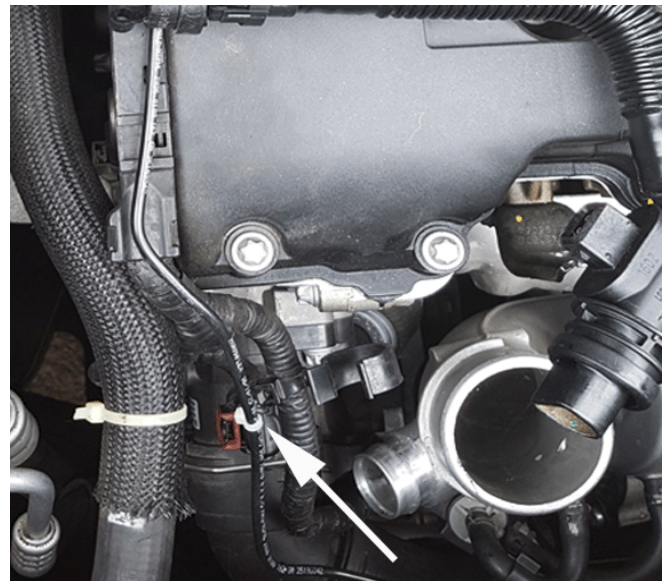

4855375

9. Using a tie strap, secure the vacuum line to the engine wiring harness.

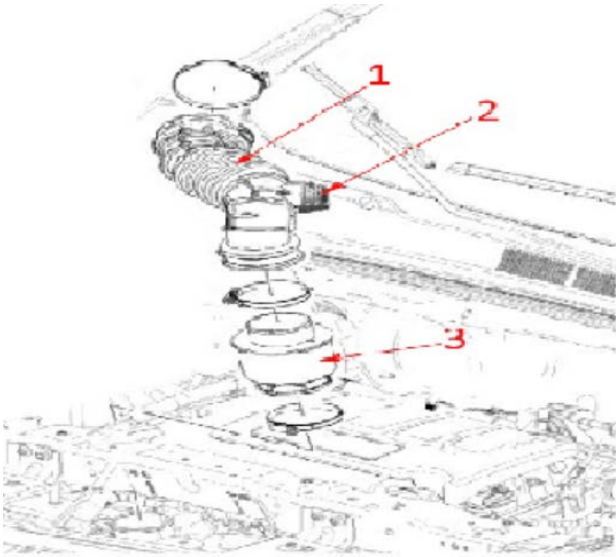

4418077

10. Install the new air cleaner outlet duct (1) and air resonator (3) assembly.
11. Using care, cut and remove the tape securing the vacuum line to the **NEW** PCV pipe.
12. Remove the vacuum line from the PCV pipe assembly.

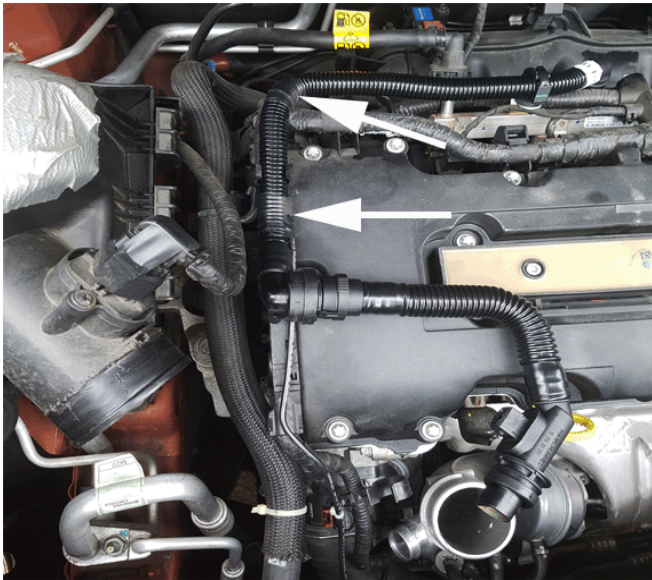

4855376

13. Install the new PCV pipe assembly.
14. Install the PCV heater into air cleaner outlet duct.
15. Using Woven Polyester Electrical Tape (PET), secure the vacuum line to the PCV pipe.

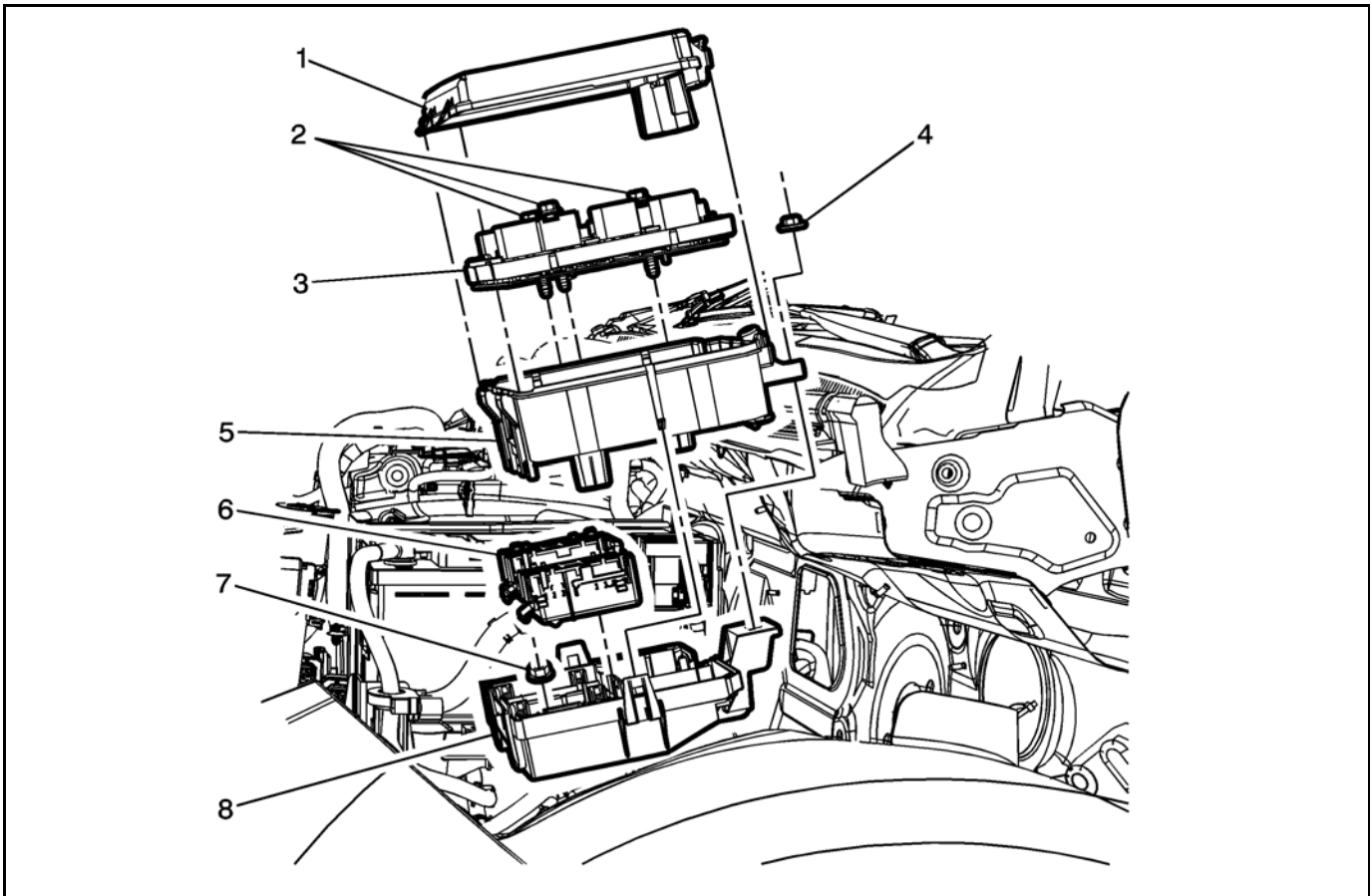

2760835

16. Remove the fuse block cover (1).
17. Remove the nut (4) that secures the upper fuse block to the body.
18. Loosen the three upper connector bolts (2).
19. Separate the upper (5) fuse block assembly from the fuse block base (8) by releasing the snap locks. Refer to *Front Compartment Fuse Block Replacement* in SI.
20. Route the PCV wiring harness under the battery tray.

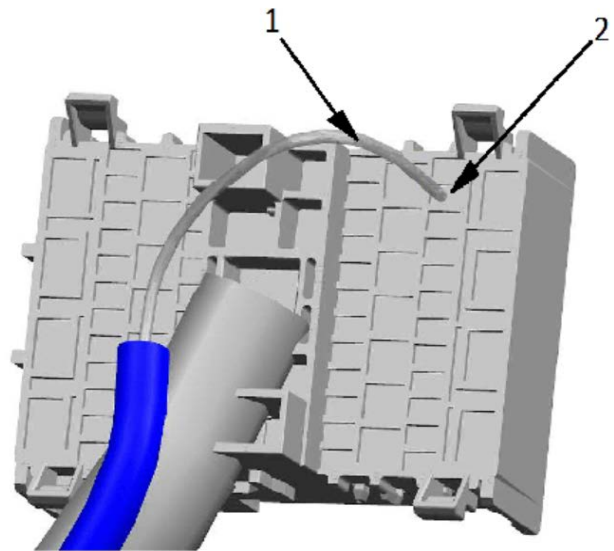

4377876

21. **For 2013-2016 model vehicles:**
 - 21.1. Remove UEX_X2 connector from the fuse block base.
 - 21.2. Remove connector cover.

21.3. Install PCV heater wiring harness terminal (1) into the J11 cavity (2).

⇒ Refer to X50A Fuse Block - Underhood X2 (Doc ID 4752878) in SI.

21.4. Route the wiring harness between the battery and fuse block.

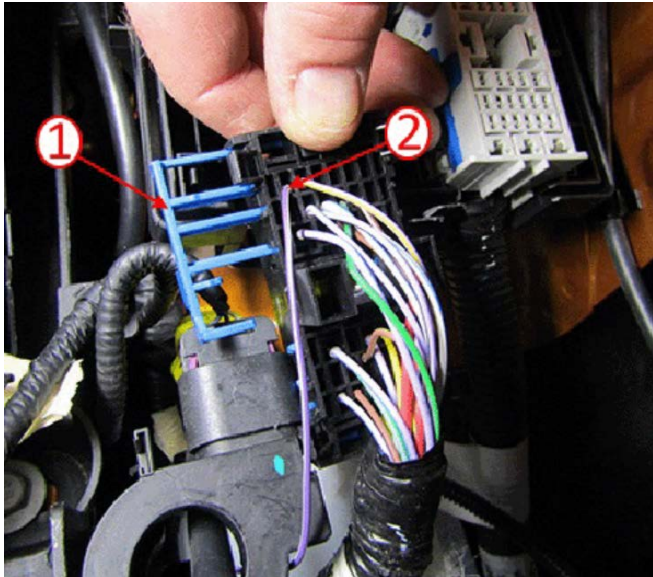

4598974

22. For 2017-2020 model vehicles:

22.1. Remove the UEX_X3 connector from the fuse block base.

22.2. Remove the connector cover.

22.3. Remove connector lock (1).

22.4. Install PCV heater wiring harness terminal into the H6 cavity (2).

⇒ Refer to X50A Fuse Block - Underhood X3 (Doc ID 4752879) in SI.

23. Using tie straps, fasten the PCV wiring harness to the connectors wiring harness at the white tape indicators.

24. Install the connector back onto the fuse block base.

Important: Only replace the fuse and install the labels on vehicles that have a 5 amp fuse. Some vehicles have the 10 amp fuse already installed and do not require replacement or the label.



4379861

25. Position and snap the upper fuse block onto the base.

Tighten

Tighten the bolts (1) to specifications. Refer to *Fastener Specifications* in SI.

26. If necessary, replace the 5 amp fuse with a 10 amp fuse into cavity F17 (2).

27. Install the front compartment fuse block cover.

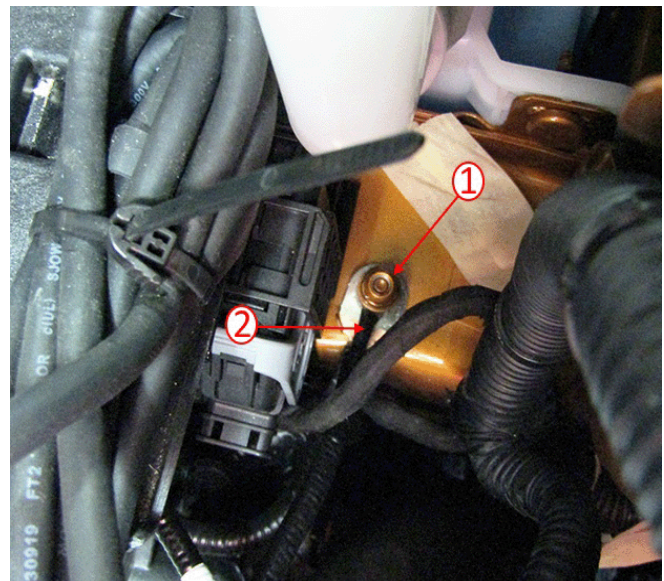

4605957

28. Install the PCV heater wiring harness ground wire (2) to ground G103 (1).

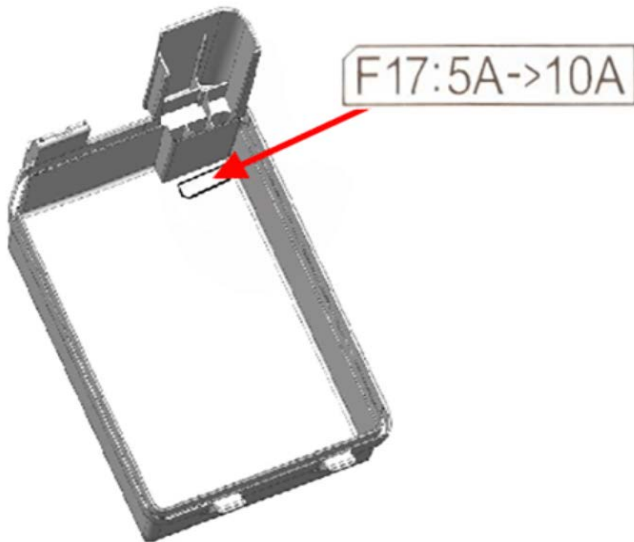

4379843

29. If necessary, install the UEC sticker onto the backside of the fuse block cover and in the owners manual under Engine Compartment Fuse Block.

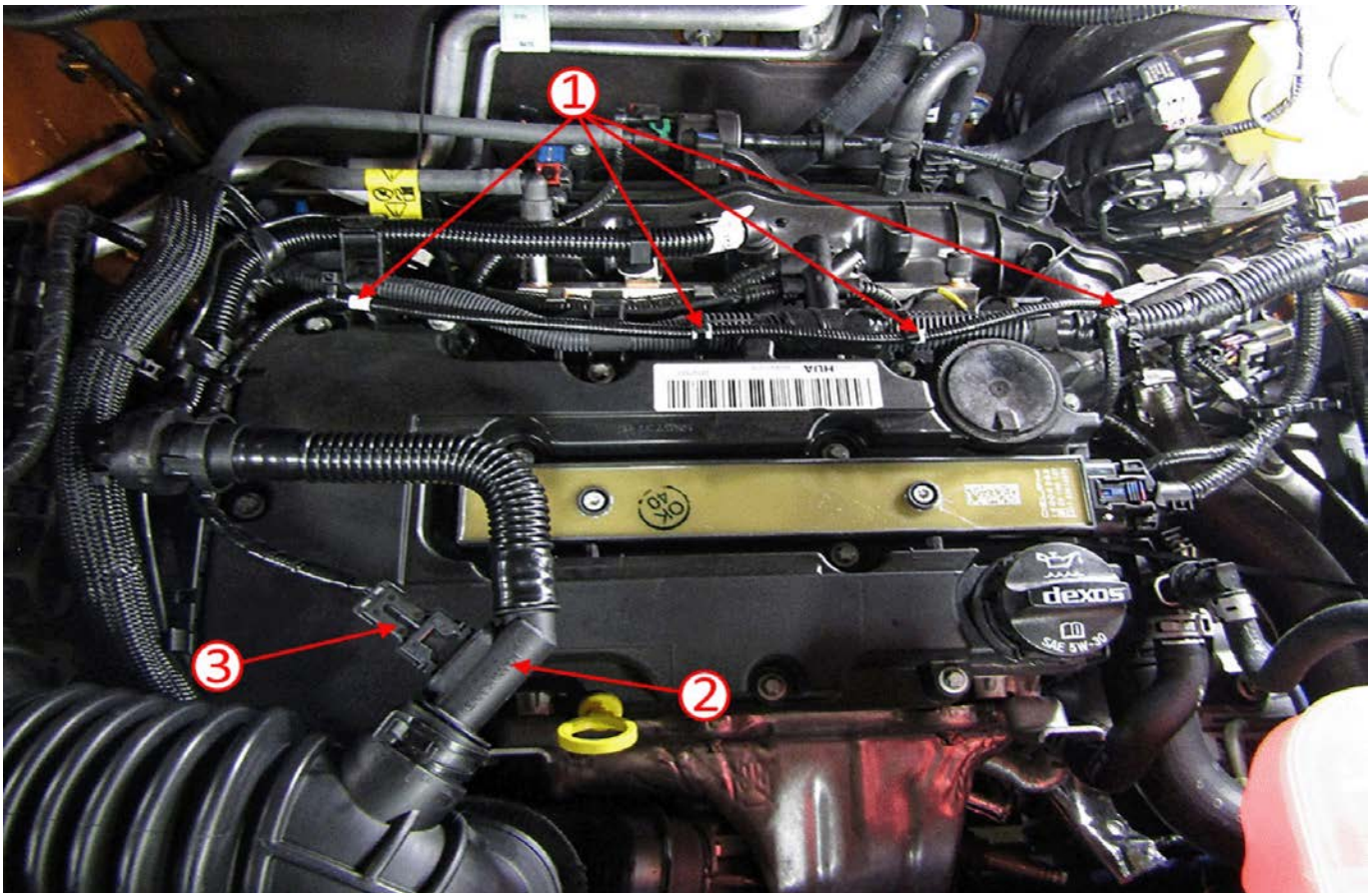

4609442

30. Route the PCV heater wiring harness across the engine wiring harness.
31. Using the tie straps, fasten the wiring harness at the white marking points (1).
32. Connect the electrical connector (3) to the PCV heater (2).
33. Install the battery.
34. Install the engine cover.
35. If required, perform an oil change. Refer to *Engine Oil and Oil Filter Replacement* in SI.

Charge Air Cooler Replacement

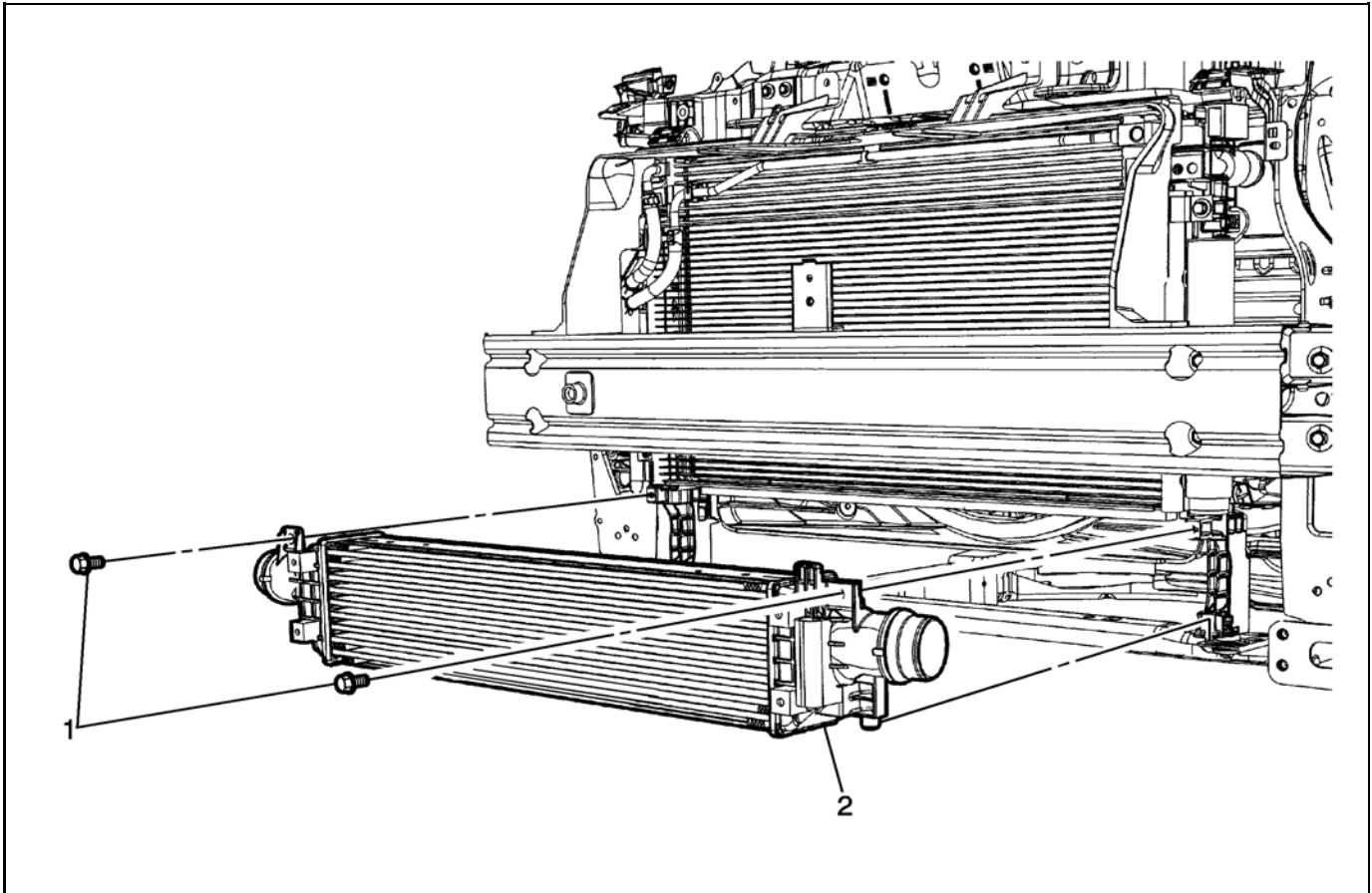

2851444

1. Remove the CAC (2). Refer to *Charge Air Cooler Replacement* in SI.
 - If the revised CAC was previously installed, drain and reinstall the revised CAC.
 - If the CAC **has not** been replaced with a new revised version, then replace the CAC.
2. Install the modified CAC.

Parts Information

Note: BUP plant = 'K' VIN pos 1

SLP plant = '3' VIN pos 1

Description	Model Year	Country	Build Prior To	Part Number	Qty
Kit, PCV Heater	2013-2016	Canada	All VINs	25198125	1
		U.S.	All VINs		
	2017-2018	Canada	All VINs	25198126	1
		U.S.	All VINs		
	2019-2021	Canada	Installed During Production	—	—
		U.S.	All VINs	12711708	1
Cooler, Charge Air	2013-2018	Canada	Built prior to Sept. 27, 2017 (VIN pos 1 = K)	42574031	1
		U.S.	All VINs		
	2013-2018	Canada	Built prior to March 19, 2018 (VIN pos 1 = 3)	42582747	1
		U.S.	All VINs		
	2019-2021	Canada	Installed During Production	—	—
		U.S.	All (VIN pos 1 = K)	42574031	1
		U.S.	All (VIN pos 1 = 3)	42582747	1
	DUCT, CHRGR AIR CLR OTLT AIR (KIT)	2013-2021	All	Built prior to October 15, 2019 (VIN pos 1 = K)	42751703
All (VIN pos 1 = 3)				Important: If the part is not available, the dealer can order a new CAC outlet hose part number 42731155.	
All			—		Refer to the Electronic Parts Catalog (EPC).
All			—		
All	—				
SEAL, INT MANIF		All	—		
Filter, Oil		All	—		
Oil		All	—		

Description	Model Year	Model	Part Number	Qty
Cover, Grille Winter	2013-2016 &VK3 (with license plate bracket)	Trax	42697325	1
	2013-2016 -VK3 (without license plate bracket)		42702689	1
	2014-2016	Note: 2020-2021 Encore will have a winter cover supplied in the vehicle. Encore	42697326	1
	2017-2021		42697332	1
	2017-2021	Trax	42697331	1

Warranty Information

Note: Only select the Labor Operation that corresponds with the repair performed.

For vehicles repaired under the Powertrain coverage, use the following labor operation. Reference the Applicable Warranties section of Investigate Vehicle History (IVH) for coverage information.

Labor Operation	Description	Labor Time
4081358*	Diagnostic System Check	0.3 hr
Add	Intake Manifold Inspection and Cleaning	1.2 hrs
Add	PCV Heater, Wiring Harness Installation	1.0 hr
Add	IAPT Inspection and Cleaning	0.2 hr
Add	Engine Oil and Oil Filter Replacement	0.3 hr
Add	Charge Air Cooler Flush and Clean	1.4 hrs
Add	Charge Air Cooler Outlet Air Duct Replacement	1.2 hrs
Add	Charge Air Cooler Replacement	1.0 hr
Add	Winter Grille Cover Installation**	0.2 hr
Add	Charge Air Bypass Valve Cleaning	0.8 hr
*This is a unique Labor Operation for bulletin use only.		
**Installation perform is a one time charge only.		

Version	19
Modified	<p>Revised December 23, 2016 – Added DTCs to the Condition and a Note to the Parts Information.</p> <p>Revised January 05, 2017 – Removed Fascia Blocker information.</p> <p>Revised January 18, 2017 – Added draining the CAC.</p> <p>Revised September 07, 2017 – Added fascia blocker removal information and added CAC part numbers.</p> <p>Revised December 05, 2017 – Added RPO LUV to Subject, added the 2018 Model Year, modified the Attention statement and added IAPT sensor information.</p> <p>Revised February 02, 2018 – Removed thaw CAC information and added connector pinout reference.</p> <p>Revised April 04, 2018 – Added the Intake Air Pressure and Temperature Sensor Inspection section, an Important statement above step 8 and additional steps 9 and 10 on how to care for the IAPT, repair breakpoints and updated Warranty Information.</p> <p>Revised September 25, 2018 – Added first Important statement for thawing vehicle after the Correction, updated the second Important statement, removed fascia blocker information before step 40 and updated the Warranty Information.</p> <p>Revised January 04, 2019 – Added Winter Cover information.</p> <p>Revised January 23, 2019 – Updated the Model Year information for P/N 42702689 in Parts Information table.</p> <p>Revised March 26, 2019 – Added the 2019 Model Year, updated Breakpoint reference in Models, updated the Cause and Correction sections, added Note after Correction section, added Intake Manifold and Cylinder Head inspection section, added graphic and Important statement on the wrong CAC tube being installed under Intake Air Pressure and Temperature sensor Inspection, removed fascia blocker step and updated step 40 of the Service Procedure and updated the Parts and Warranty Information sections.</p> <p>Revised January 08, 2020 – Added the 2020 Model Year, updated the service procedures and updated the Parts Information section to add a new CAC Duct Part Kit, an Important statement under P/N 42751703 and a Note statement for 2020 Encore vehicles receiving winter covers.</p> <p>Revised March 18, 2020 – Added a Special Coverage reference in the Attention statement, clarified the Warning statement and added a video under Grille Winter Cover Installation, and updated the Charge Air Cooler Outlet Air Elbow Duct Replacement section by adding the CAC design inspection step.</p> <p>Revised May 04, 2020 – Added fluid removal from the intake manifold and charge air bypass valve inspection and cleaning steps in the Intake Manifold and Cylinder Head Inspection section.</p> <p>Revised February 12, 2021 – Added the 2021 Model Year, updated the 2019-2021 MY PCV KIT part number and added 2021 to the Parts Information section.</p> <p>Revised September 26, 2022 – Replaced P0236 with P0234 and Updated the Correction section Information.</p> <p>Revised January 05, 2023 – Removed the Information under Intake Manifold and Cylinder Head Inspection and added reference to service bulletin 22-NA-067.</p> <p>Revised May 05, 2023 – Added the last Note and reference to Bulletin # 22-NA-067 to Correction section.</p>

