

# Service Alert

Mazda North American Operations  
Irvine, CA 92618-2922



<b>Subject:</b>  <b>Qi WIRELESS CHARGER SYMPTOM TROUBLESHOOTING</b>	<b>Service Alert No.: SA-021/23</b>
	<b>Last Issued : 04/14/2023</b>

## BULLETIN NOTES

This SA supersedes the previously issued SA(s) listed below. The changes are noted in Red.

Previous SAs:	Date(s) Issued:
SA-028/22	05/02/22

## APPLICABLE MODEL(S)/VINS

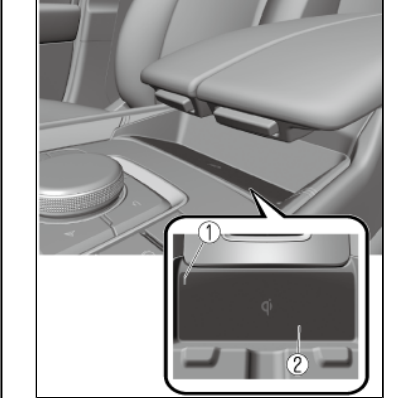
<p>2024 CX-90 equipped with factory installed Qi Wireless Charger</p>	 <p>1. Charging area 2. LED indicator</p>
<p>2023 CX-50 equipped with factory installed Qi Wireless Charger 2023 CX-50 equipped with Mazda Genuine Accessory Qi Wireless Charger</p>	 <p>1. LED indicator 2. Charging area</p>

**CONSUMER NOTICE:** The information and instructions in this bulletin are intended for use by skilled technicians. Mazda technicians utilize the proper tools/ equipment and take training to correctly and safely maintain Mazda vehicles. These instructions should not be performed by "do-it-yourselfers." Customers should not assume this bulletin applies to their vehicle or that their vehicle will develop the described concern. To determine if the information applies, customers should contact their nearest authorized Mazda dealership. Mazda North American Operations reserves the right to alter the specifications and contents of this bulletin without obligation or advance notice. All rights reserved. No part of this bulletin may be reproduced in any form or by any means, electronic or mechanical---including photocopying and recording and the use of any kind of information storage and retrieval system ---without permission in writing.

2022-2023 CX-5 equipped with factory installed Qi Wireless Charger  
 2021-2023 CX-9 equipped with factory installed Qi Wireless Charger

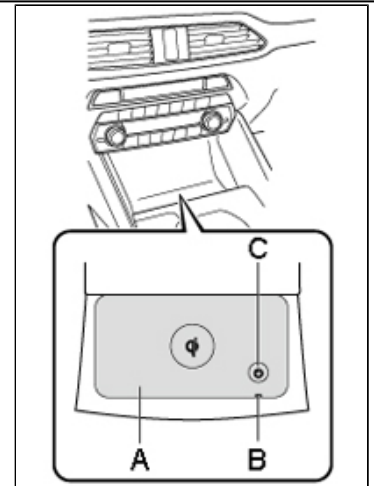

- A - Charging Area
- B - Indicator
- C - Power Button

2019-2023 Mazda3 equipped with Mazda Genuine Accessory Qi Wireless Charger  
 2020-2023 CX-30 equipped with Mazda Genuine Accessory Qi Wireless Charger



- A - Charging Area
- B - Indicator

**CONSUMER NOTICE:** The information and instructions in this bulletin are intended for use by skilled technicians. Mazda technicians utilize the proper tools/ equipment and take training to correctly and safely maintain Mazda vehicles. These instructions should not be performed by "do-it-yourselfers." Customers should not assume this bulletin applies to their vehicle or that their vehicle will develop the described concern. To determine if the information applies, customers should contact their nearest authorized Mazda dealership. Mazda North American Operations reserves the right to alter the specifications and contents of this bulletin without obligation or advance notice. All rights reserved. No part of this bulletin may be reproduced in any form or by any means, electronic or mechanical--including photocopying and recording and the use of any kind of information storage and retrieval system ---without permission in writing.



**DESCRIPTION**

**Index**

[Symptom Troubleshooting](#)

[LED Indicator / Infotainment Display Icon](#)







[Supplemental Information](#)

	CX-50 Factory Installed and Mazda Genuine Accessory <b>CX-5, CX-9 and CX-90</b> Factory Installed	Mazda3 and CX-30 Mazda Genuine Accessory Qi Wireless Charger
Symptom	Possible Cause	
<b>Phone will not charge</b>	<ul style="list-style-type: none"> <li>Device is not compatible with Qi wireless charging standards (see trademark below)</li> </ul>  <ul style="list-style-type: none"> <li>Phone case is not compatible with Qi wireless charging standards                             <ul style="list-style-type: none"> <li>Most phone cases will list compatibility on the packaging</li> <li>None approved phone cases with magnets or metal plates</li> </ul> </li> <li>The engine is not running</li> <li>Doors and/or liftgate is open</li> <li>The mobile device is fully charged.</li> <li>Foreign matter between the device and the charging area</li> <li>The temperature of the mobile device is high</li> <li>The mobile device is placed with the charging side facing upward</li> <li>The mobile device is placed in a position extremely deviating from the center of the charging area</li> <li>The Near Field Communication (NFC) function setting of the mobile device is on (depends on the model of the mobile device)</li> </ul>	<ul style="list-style-type: none"> <li>Device is not compatible with Qi wireless charging standards (see trademark below)</li> </ul>  <ul style="list-style-type: none"> <li>Phone case is not compatible with Qi wireless charging standards                             <ul style="list-style-type: none"> <li>Most phone cases will list compatibility on the packaging</li> <li>None approved phone cases with magnets or metal plates</li> </ul> </li> <li>Ignition Off</li> <li>The mobile device is placed in a position extremely deviating from the center of the charging area</li> <li>The temperature of the mobile device is high</li> <li>LED indicator error (<a href="#">see table below</a>)</li> </ul>

**CONSUMER NOTICE:** The information and instructions in this bulletin are intended for use by skilled technicians. Mazda technicians utilize the proper tools/ equipment and take training to correctly and safely maintain Mazda vehicles. These instructions should not be performed by "do-it-yourselfers." Customers should not assume this bulletin applies to their vehicle or that their vehicle will develop the described concern. To determine if the information applies, customers should contact their nearest authorized Mazda dealership. Mazda North American Operations reserves the right to alter the specifications and contents of this bulletin without obligation or advance notice. All rights reserved. No part of this bulletin may be reproduced in any form or by any means, electronic or mechanical--including photocopying and recording and the use of any kind of information storage and retrieval system ---without permission in writing.

	<ul style="list-style-type: none"> <li>• Your vehicle is in an area where strong radio waves or electrical noise occur such as near a television tower, power plant, or airport.</li> <li>• Power Turned OFF             <ul style="list-style-type: none"> <li>◦ Function can be switched on/off by pressing the power button on the Wireless Charger (Qi) for approx. 3 seconds</li> </ul> </li> <li>• LED indicator error (<a href="#">see table below</a>)</li> <li>• DTC is stored</li> <li>• Noise interference reduction function ON             <ul style="list-style-type: none"> <li>• Function can be switched on/off by pressing the power button on the Wireless Charger (Qi) for approx. 1 sec</li> </ul> </li> </ul>	
<p><b>Resources</b></p>	<p>Go to MGSS:</p> <ul style="list-style-type: none"> <li>• CX-50 <a href="#">WIRELESS CHARGER (Qi) INSPECTION</a></li> <li>• CX-9 <a href="#">WIRELESS CHARGER (Qi) INSPECTION</a></li> <li>• CX-5 <a href="#">WIRELESS CHARGER (Qi) INSPECTION</a></li> </ul>	

**CONSUMER NOTICE:** The information and instructions in this bulletin are intended for use by skilled technicians. Mazda technicians utilize the proper tools/ equipment and take training to correctly and safely maintain Mazda vehicles. These instructions should not be performed by "do-it-yourselfers." Customers should not assume this bulletin applies to their vehicle or that their vehicle will develop the described concern. To determine if the information applies, customers should contact their nearest authorized Mazda dealership. Mazda North American Operations reserves the right to alter the specifications and contents of this bulletin without obligation or advance notice. All rights reserved. No part of this bulletin may be reproduced in any form or by any means, electronic or mechanical---including photocopying and recording and the use of any kind of information storage and retrieval system ---without permission in writing.

CX-50, CX-90 Factory Installed and Mazda Genuine Accessory		CX-5 and CX-9 Factory Installed	Mazda3 and CX-30 Mazda Genuine Accessory
LED Indicator	Infotainment Display Icon	LED Indicator	LED Indicator
No light - System Off	---	<ul style="list-style-type: none"> <li>No light - System Off</li> <li>White - Stand-by (charging is possible)</li> <li>Amber - Normal charging</li> <li>Green - Fast charging</li> <li>Flashing Amber - Normal charging (charging efficiency is low)</li> <li>Flashing Green - Fast charging (charging efficiency is low)</li> <li>Flashing White - Stand-by (charging is not possible)</li> <li>Flashing red (high temperature)</li> <li>Solid red (charger malfunction)</li> </ul>	<ul style="list-style-type: none"> <li>No light - System Off</li> <li>White - Stand-by (charging is possible)</li> <li>Green - Charging</li> <li>Flashing White - Charge Complete *2</li> <li>Orange (foreign matter detected or device high temp)</li> <li>Red (charger malfunction)</li> </ul>
White - Charging is possible			
Amber - Normal charging			
Green - Fast charging *1			
Flashing White - Charging conditions are not met *3			
Flashing red - Charging is not possible because a high temperature is detected			
Flashing red - Charging is not possible because foreign matter is detected			
Solid red - There is a problem with the Wireless Charger (Qi) and it needs to be repaired by an Authorized Mazda Dealer			

\*1: Some mobile devices can switch between normal charging and fast charging.

\*2: \*For some types of mobile device, the indicator may remain green even when charging is complete.

\*3: Charging conditions:

- a. Engine is running
- b. Qi compatible device placed in center of the charging area on the tray
- c. Doors and liftgate are closed

**CONSUMER NOTICE:** The information and instructions in this bulletin are intended for use by skilled technicians. Mazda technicians utilize the proper tools/ equipment and take training to correctly and safely maintain Mazda vehicles. These instructions should not be performed by "do-it-yourselfers." Customers should not assume this bulletin applies to their vehicle or that their vehicle will develop the described concern. To determine if the information applies, customers should contact their nearest authorized Mazda dealership. Mazda North American Operations reserves the right to alter the specifications and contents of this bulletin without obligation or advance notice. All rights reserved. No part of this bulletin may be reproduced in any form or by any means, electronic or mechanical--including photocopying and recording and the use of any kind of information storage and retrieval system ---without permission in writing.

**CX-50 Genuine Mazda Accessory Qi Wireless Charger Supplemental Information**

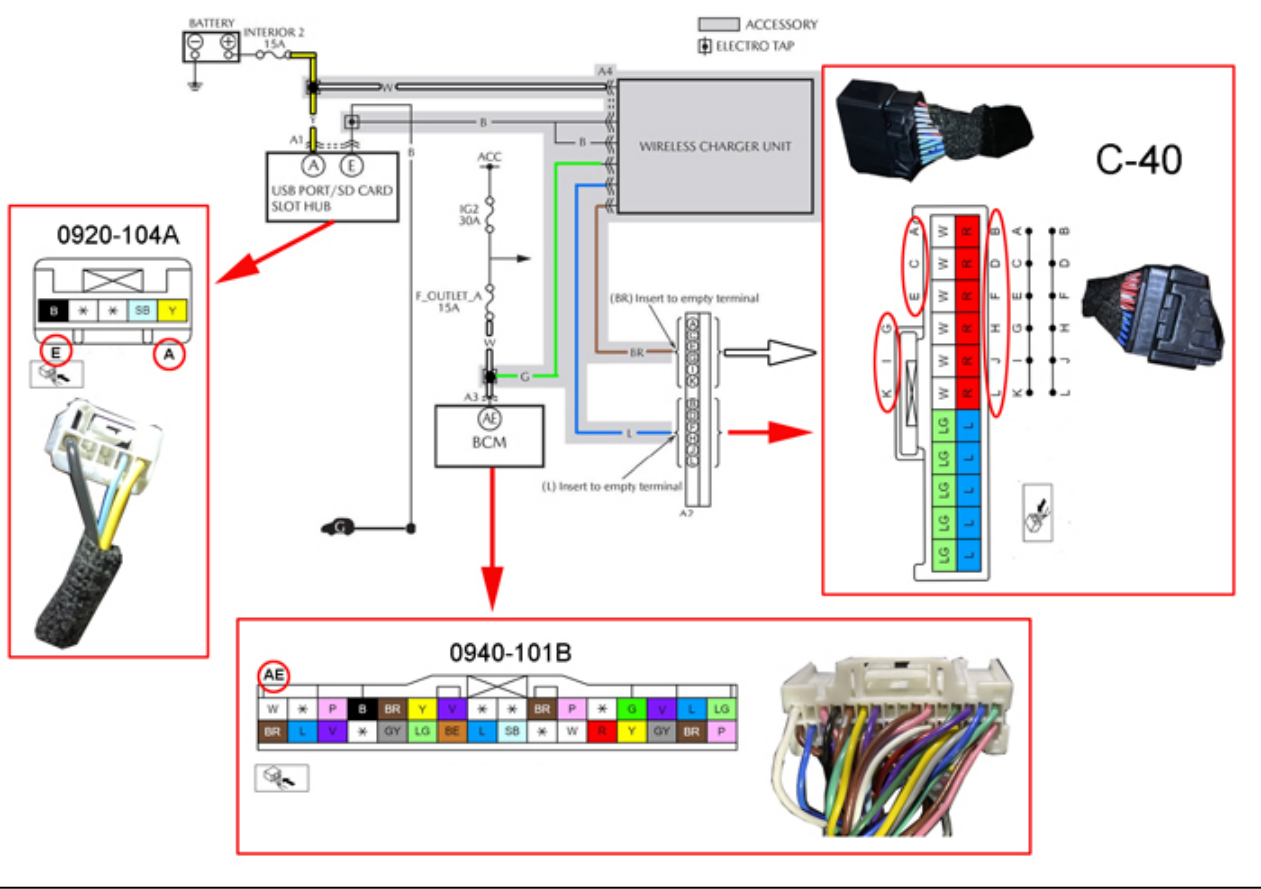

**CONSUMER NOTICE:** The information and instructions in this bulletin are intended for use by skilled technicians. Mazda technicians utilize the proper tools/ equipment and take training to correctly and safely maintain Mazda vehicles. These instructions should not be performed by "do-it-yourselfers." Customers should not assume this bulletin applies to their vehicle or that their vehicle will develop the described concern. To determine if the information applies, customers should contact their nearest authorized Mazda dealership. Mazda North American Operations reserves the right to alter the specifications and contents of this bulletin without obligation or advance notice. All rights reserved. No part of this bulletin may be reproduced in any form or by any means, electronic or mechanical---including photocopying and recording and the use of any kind of information storage and retrieval system ---without permission in writing.