



SIB 61 03 23

2023-03-08

GEAR SELECTOR SWITCH (GWS) BUTTONS OR INDICATOR LIGHTING MALFUNCTION

<input type="checkbox"/>	THIS REPAIR IS MOBILE FRIENDLY
--------------------------	--------------------------------

MODEL

E-Series	Model Description	Production Date
F39	X2 Sports Activity Coupe	01/01/2022 – 09/30/2022
F48	X1 Sports Activity Vehicle	

SITUATION

The buttons on the gear selector switch (GWS) do not work, or the function indicator lighting has failed.

One or more of the following faults are saved in the fault memory for the gear selector switch (GWS):

- **80268E**- Park button sticking
 - and/or
- **80268F**- Parking button defective
 - and/or
- **802680**- Functional display defective
 - and/or
- **802681**- Locator lighting defective
 - and/or
- **802691** - Release button faulty

CAUSE

Damage to the shift box (Selector Lever) ribbon cable.

CORRECTION

Replace the shift box, then reassess the vehicle.

If errors are still present, then replace the gear selector switch (GWS).

PROCEDURE

In the event of a customer complaint,

1. Perform a vehicle test using ISTA, read fault memory and diagnose any relevant faults.

2. Replace the Shift box (Selector Lever), refer to repair instructions **25 11 007** “**Removing and installing gearshift bracket**”.

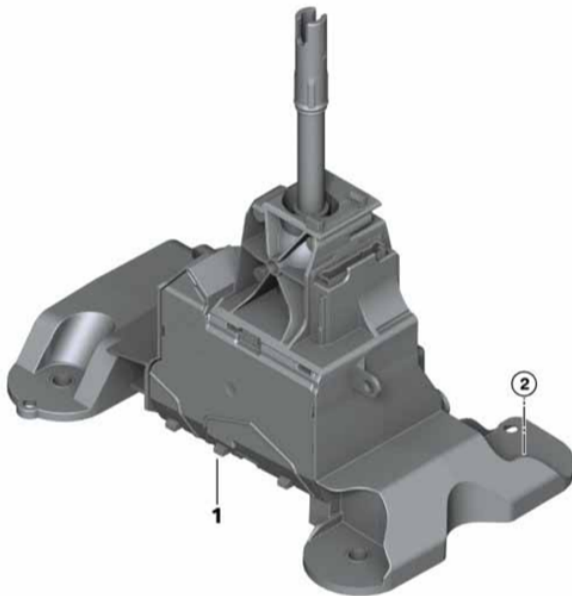

3. Utilizing ISTA, clear any fault codes induced by the defective ribbon cable.

4. Perform a sleep cycle until the hazard warning switch light goes out, this can take up to 30 minutes.

5. Wake the vehicle and verify the effectiveness of the repair by testing the functionality of the GWS.

Does the GWS operate as designed? (Buttons, lighting, etc.)

Yes: No further action is necessary.

No: Proceed to step 6.



1. Replace the gear selector switch (GWS), refer to repair instructions **61 31 342 “Removing and installing gear selector switch”**.

2. Connect the vehicle to a BMW-approved battery charger/power supply (refer to SI B04 23 10).

3. Program the vehicle utilizing the latest version of ISTA, clear any fault codes induced by the defective ribbon cable.

4. Perform a sleep cycle until the hazard warning switch light goes out, this can take up to 30 minutes.

5. Wake the vehicle and verify the effectiveness of the repair by testing the operation of the GWS.

Does the GWS operate as designed? (Buttons, lighting, etc.)

Yes: No further action is necessary.

No: Further diagnosis with ISTA is needed.

Note: ISTA will automatically reprogram and code all programmable control modules that do not have the latest software.

Always connect a BMW-approved battery charger/power supply ([SIB 04 23 10](#)).

For information on programming and coding with ISTA, refer to Dealer Universal Portal / TIS / Technical Documentation / Diagnostics and Programming / Programming Documentation.

PARTS INFORMATION

Obtain and confirm the part numbers for your specific vehicle by entering the chassis number in either ETK or AIR which considers specific equipment and/or options.

Part Number	Description	Quantity
Refer to ETK	Shift box, gear selection switch	1
And, if needed:		
Refer to ETK	Gear selector switch (GWS)	1

CLAIM INFORMATION

Covered under the terms of the BMW New Vehicle Limited Warranty for Passenger Cars and Light Trucks or the BMW Certified Pre-Owned Program.

Defect Code:	6131711500	Electric gear selector switch Permanent malfunction
---------------------	-------------------	--

Refer to AIR for the corresponding flat rate unit (FRU) allowances.

Diagnosis

Labor Operation	Description	Labor Allowance
00 00 006	Performing vehicle test (with vehicle diagnosis system)	Refer to AIR
Or:		
00 00 556	Performing vehicle test (with vehicle diagnosis system – checking faults) (Plus work)	Refer to AIR
And:		
61 21 528	Support voltage of the vehicle electrical system / recharge vehicle electrical system battery (at support point in engine compartment)	Refer to AIR
And, as necessary:		
61 00 006*	Performing vehicle diagnosis – test module (Work time)	WT
Or		
00 58 500*	Diagnosis Worktime Flat Rate (See below)	2 FRU

Labor operation code 00 00 006 is a Main labor operation. If you are using a Main labor code for another repair, use the Plus code labor operation 00 00 556 instead.

Work time labor operation codes 61 00 006 and 00 58 500 are not considered Main labor operations.

And, with the above diagnosis as applicable:

Step 2: Replace the Shift box (Selector Lever)

Labor Operation	Description	Labor Allowance
61 31 861	Replacing gear selector switch switchbox (After vehicle diagnosis)	Refer to AIR

And when:

Step 6 also applies: Replace the gear selector switch (GWS)

Labor Operation	Description (Associated work)	Labor Allowance
61 31 843	Replacing gear selector switch (After vehicle diagnosis)	Refer to AIR

After Step 6, only when the following procedure shows required to be performed:

Copyright ©2023 BMW of North America, Inc.

Labor Operation	Description	Labor Allowance
61 00 730	Programming/encoding control unit(s)	Refer to AIR

Programming and Encoding - Vehicle Control Units

During the workshop visit for this repair procedure, the above vehicles may also show one or more programming and encoding Technical Campaign repairs open, the programming and encoding procedure may only be invoiced one time.

If you should have this situation, update the vehicle to the required I-level or higher by performing and submitting for it through one of these open Technical Campaigns instead.

Please be sure to also perform any additional before and/or after work (including attaching labels) as required by the open campaigns on the vehicle. Close any other open programming and encoding Campaign repairs as outlined in the corresponding Service Information Bulletin.

Programming and Encoding – Additional Work (RO and Claim Comments Required)

This procedure automatically reprograms and encodes any vehicle control modules that do not have the latest software I-level.

If one or more control modules fail during the reprogramming procedure, claim the required consequential repair work procedures to address this issue (including performing the IRAP Control Unit Recovery first as required, refer to the SIB in AIR) under the Defect Code in this bulletin with the labor operations in AIR that apply.

Please explain the additional work procedures that were performed (The why and the what) on the repair order and in the claim comments.

For covered repairs that address control module failures that occurred prior to performing this reprogramming procedure, claim this work with the Defect Code and labor operations (including the diagnosis that applies*) in AIR that apply.

Based on which one applies to your center, please refer to **SI B01 01 20** or **B01 07 20** for the applicable procedure for documenting, claiming, and explaining, on the RO and in the claim comments, your diagnosis work time (WT), job/repair work time (WT), and the vehicle repairs your center performed, unless otherwise required by State law.

Covered under the terms of the BMW New Vehicle Limited Warranty for Passenger Cars and Light Trucks, or the BMW Certified Pre-Owned Program as described below.

FEEDBACK REGARDING THIS BULLETIN

Technical Feedback	To submit feedback for the technical topic of this bulletin: Submit your feedback in the rating box at the top of this bulletin
Warranty Feedback	To submit feedback for the CLAIMS section of this bulletin: Submit an IDS ticket to the Warranty Department, or use the chat available in the Warranty Documentation Portal
Parts Feedback	To submit feedback for the PARTS section of this bulletin: Submit an IDS ticket to the Parts Department

