



Revision 1 February 2023

Dealer Service Instructions for:

Customer Satisfaction Notification ZD8 Coolant Leak

NOTE: Added additional information in the “Parts Information” section.

Remedy Available

2021-2022 (JL) Jeep® Wrangler

NOTE: This campaign applies only to the above vehicles equipped with a 2.0L engine (sales code EC1, EC3 & ECX).

NOTE: Some vehicles above may have been identified as not involved in this campaign and therefore have been excluded from this campaign.

IMPORTANT: Some of the involved vehicles may be in dealer new vehicle inventory. Dealers should complete this campaign service on these vehicles before retail delivery. Dealers should also perform this repair on vehicles in used vehicle inventory and those vehicles in for service. Involved vehicles can be determined by using the VIP inquiry process.

Subject

The coolant inlet tube fasteners on about 90,811 of the above vehicles may become loose and allow a coolant weep that may propagate into a drip. Loss of coolant can cause the engine to overheat and, if not addressed, can lead to engine failure.

Repair

Remove the coolant inlet tube fasteners each separately. Clean the threads and add Thread Loc to the threads and reinstall, tighten to 11N·m (8ft. lbs.).

Parts Information

<u>Part Number</u>	<u>Description</u>
04318031	Lock & Seal Adhesive (MS-90061) MSQ of 12

NOTE: One tube will cover many vehicles. Each repair requires few drops of Lock & Seal Adhesive.

Dealers are not to charge for the entire tube of Lock & Seal Adhesive on each claim.

Parts Return

No parts return required for this campaign.

Special Tools

No special tools are required to perform this service procedure.

Service Procedure

1. Remove the clean air hose.
2. Remove the electric vacuum pump.
3. Remove one of the coolant inlet tube fasteners (1), clean threads and add thread Loctite.
4. Install the fastener and tighten the fastener to 11N·m (8ft. lbs.).
5. Repeat with the other fastener.
6. Re-install the electric vacuum pump.
7. Re-install the clean air hose.
8. Check coolant level, add as necessary.
9. Check for coolant leak.
10. Return the vehicle to the customer.

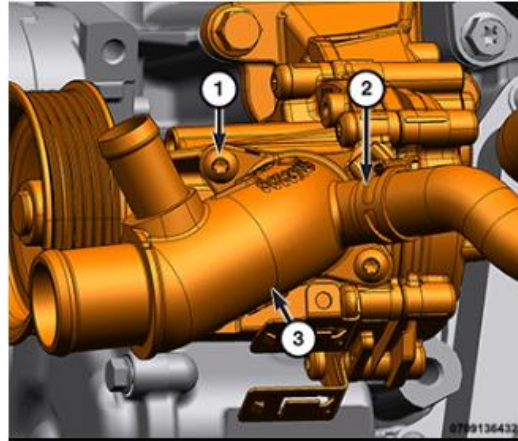

- 1 - Water Pump Inlet Tube Screws
- 2 - Coolant Hose
- 3 - Water Pump Inlet Tube

Completion Reporting and Reimbursement

Claims for vehicles that have been serviced must be submitted on the DealerCONNECT Claim Entry Screen located on the Service tab. Claims paid will be used by FCA to record Customer Satisfaction Notification service completions and provide dealer payments.

Use the following labor operation number and time allowance:

	Labor Operation Number	Time Allowance
Add Thread Loc to Inlet tube fasteners	07-ZD-81-82	0.6 hours

NOTE: See the Warranty Administration Manual, Recall Claim Processing Section, for complete claim processing instructions.

Dealer Notification

To view this notification on DealerCONNECT, select “Global Recall System” on the Service tab, then click on the description of this notification.

Owner Notification and Service Scheduling

All involved vehicle owners known to FCA are being notified of the service requirement by mail. They are requested to schedule appointments for this service with their dealers. A generic copy of the owner letter is attached.

Vehicle Lists, Global Recall System, VIP and Dealer Follow Up

All involved vehicles have been entered into the DealerCONNECT Global Recall System (GRS) and Vehicle Information Plus (VIP) for dealer inquiry as needed.

GRS provides involved dealers with an updated VIN list of their incomplete vehicles. The owner's name, address and phone number are listed if known. Completed vehicles are removed from GRS within several days of repair claim submission.

To use this system, click on the “**Service**” tab and then click on “**Global Recall System.**” Your dealer's VIN list for each campaign displayed can be sorted by: those vehicles that were unsold at campaign launch, those with a phone number, city, zip code, or VIN sequence.

Dealers should perform this repair on all unsold vehicles before retail delivery. Dealers should also use the VIN list to follow up with all owners to schedule appointments for this repair.

VIN lists may contain confidential, restricted owner name and address information that was obtained from the Department of Motor Vehicles of various states. Use of this information is permitted for this notification only and is strictly prohibited from all other use.

Additional Information

If you have any questions or need assistance in completing this action, please contact your Service and Parts District Manager.

Customer Service / Field Operations
FCA US LLC

This notice applies to your vehicle,

[Model Year and Model]

VIN XXXXXXXXXXXXXXXXXXXX

ZD8

LOGO

VEHICLE PICTURE

YOUR SCHEDULING OPTIONS

- 1. RECOMMENDED OPTION**
Call your authorized Chrysler / Dodge / Jeep® / RAM Dealership
- 2. Call the FCA Recall Assistance Center at 1-800-853-1403. An agent can confirm part availability and help schedule an appointment**
- 3. Visit recalls.mopar.com, scan the QR code below, or download the Mopar Owner's Companion App.**

QR Code

Get access to recall notifications, locate your nearest dealer, and more through this website or Mopar Owner's Companion App. You will be asked to provide your Vehicle Identification Number (VIN) to protect and verify your identity.

DEALERSHIP INSTRUCTIONS

Please reference CSN ZD8.

CUSTOMER SATISFACTION NOTIFICATION

Coolant Leak

Dear [Name],

At FCA US LLC, we recognize that the success of our business depends on the satisfaction of our customers. We are constantly monitoring the quality of our products and looking for opportunities to improve our vehicles even after they are sold. Because your long-term satisfaction is important to us, we are contacting you on important improvements we would like to make to your vehicle ^[1]. This will be done at no charge to you.

We are recommending the following improvements be performed on certain [2021 – 2022 Model Year (JL) Jeep Wrangler] vehicles.

WHY DOES MY VEHICLE NEED REPAIRS?

The coolant inlet tube fasteners on your vehicle may become loose and allow a coolant weep to propagate into a drip. **Loss of coolant can cause the engine to overheat and, if not addressed, can lead to engine failure.**

HOW DO I RESOLVE THIS CUSTOMER SATISFACTION NOTIFICATION?

FCA US will repair your vehicle free of charge (parts and labor). To do this, your dealer will remove the fasteners and add thread sealant. The estimated repair time is about 1 hour. In addition, your dealer will require your vehicle for proper check-in, preparation, and check-out during your visit, which may require more time. Your time is important to us, so we recommend that you schedule a service appointment to minimize your inconvenience. Please bring this letter with you to your dealership.

**TO SCHEDULE YOUR FREE REPAIR,
CALL YOUR CHRYSLER, DODGE, JEEP OR RAM DEALER TODAY**

WHAT IF I ALREADY PAID TO HAVE THIS REPAIR COMPLETED?

If you have already experienced this specific condition and have paid to have it repaired, you may visit www.fcarecallreimbursement.com to submit your reimbursement request online. ^[2] Once we receive and verify the required documents, reimbursement will be sent to you within 60 days. If you have had previous repairs performed and/or already received reimbursement, you may still need to have the repair performed.

We apologize for any inconvenience, but are sincerely concerned about your satisfaction. Thank you for your attention to this important matter.

Customer Assistance/Field Operations
FCA US LLC



Mr. Mrs. Customer
1234 Main Street
Hometown, MI 48371

[1] If you no longer own this vehicle, please help us update our records. Call the FCA Recall Assistance Center at 1-800-853-1403 to update your information.

[2] You can also mail in your original receipts and proof of payment to the following address for reimbursement consideration: FCA Customer Assistance, P.O. Box 21-8004, Auburn Hills, MI 48321-8007, Attention: Recall Reimbursement.