

Snow Intrusion Preventing Front Door From Fully Opening

Service Category Vehicle Exterior

Section Body Structure

Market USA

Toyota Supports
 ASE Certification 

Applicability

YEAR(S)	MODEL(S)	ADDITIONAL INFORMATION
2016 - 2023	Tacoma	

REVISION NOTICE

March 29, 2023 Rev2:

- Applicability has been updated to include 2022 – 2023 model year Tacoma vehicles.

April 27, 2021 Rev1:

- Applicability has been updated to include 2020 – 2021 model year Tacoma vehicles.
- Any previous printed versions of this bulletin should be discarded.

Introduction

Some 2016 – 2023 model year Tacoma vehicles may exhibit a condition where snow or ice builds up between the right or left front door and front fender, preventing the front door from fully opening. Follow the Repair Procedure in this bulletin to address this condition.

Warranty Information

OP CODE	DESCRIPTION	TIME	OFP	T1	T2
BD1901	Remove and Modify Foam Block, RH	0.7	53827-04020	99	99
Combo A	Opposite Side	0.6	53828-04020		

APPLICABLE WARRANTY

- This repair is covered under the Toyota Basic Warranty. This warranty is in effect for 36 months or 36,000 miles, whichever occurs first, from the vehicle's in-service date.
- Warranty application is limited to occurrence of the specified condition described in this bulletin.

Snow Intrusion Preventing Front Door From Fully Opening

Parts Information

PART NUMBER	PART NAME	QTY
53827-04020	Protector, FR Fender Side, RH	1
53828-04020	Protector, FR Fender Side, LH	1
67895-04020	Weatherstrip, RR Door No. 3, RH*	1
53855-04010	Pad, FR Wheel Opening Extension No. 2, RH*	1
90189-06236	Grommet (Clip)	7 (per Side)
55355-0C050	Cushion, Instrument Panel, No. 1	1 (per Side)

*Even though the part descriptions say "RH," the weatherstrip and pad are the same for the right and left sides.

Required Tools & Equipment

REQUIRED TOOLS & MATERIAL	QUANTITY
Heat Gun	1
Isopropyl Alcohol	1
Hacksaw or Equivalent Blade	1
Sandpaper or Handheld Sanding Tool	1

Repair Procedure

1. Confirm the condition exists.

Is there snow or ice buildup between the right or left front door and front fender that prevents the front door from fully opening?

 - **YES** — Continue to step 2.
 - **NO** — This bulletin does NOT apply. Continue diagnosis using the applicable Repair Manual.

2. Clean off the vehicle.
 - A. Remove the snow.
 - B. Melt ANY ice using a heat gun.

NOTICE

Be careful NOT to damage the finished surface while using the heat gun.

- C. Open the door to a fully open position.

Snow Intrusion Preventing Front Door From Fully Opening

Repair Procedure (continued)

3. Place the vehicle on a lift to remove the right or left front tire and wheel.

4. Remove the right or left front mudguard by removing the five bolts.
 Refer to TIS, applicable model and model year Repair Manual:
 - 2016 – 2023 Tacoma:
Vehicle Exterior – Exterior Panels/Trim – [“Exterior: Fender Panel Mudguard: Removal”](#)

5. Remove the right or left front fender wheel opening molding next to the door.
 Refer to TIS, applicable model and model year Repair Manual:
 - 2016 – 2023 Tacoma:
Vehicle Exterior – Exterior Panels/Trim – [“Exterior: Wheel Opening Moulding: Removal”](#)

- A. Peel back the section next to the door.

NOTE

BEFORE removing the right or left front fender wheel opening molding, make sure the vehicle is at room temperature.
 The front wheel opening extension pad is a nonreusable part.

- B. Cut away the seven clips closest to the door side of the front fender liner.

Figure 1.

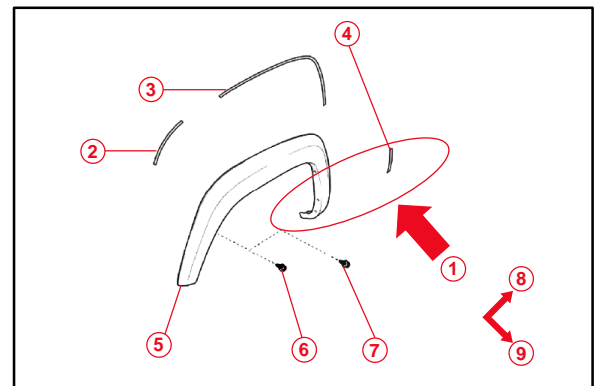

1	Peel Back Section
2	Front Wheel Opening Extension Pad
3	No. 1 Front Wheel Opening Extension Pad
4	No. 2 Front Wheel Opening Extension Pad
5	Front Fender Wheel Opening Molding
6	Bolt
7	Bolt With Mudguard
8	RR
9	Outboard

Snow Intrusion Preventing Front Door From Fully Opening

Repair Procedure (continued)

- C. Cut a 105-mm (4.1-in.) extrusion section from the RR door No. 3 weatherstrip (do NOT use the injection molded joints).

NOTE

RR door No. 3 weatherstrip (P/N 67895-04020) can be used for both the right and left countermeasure.

Figure 2.

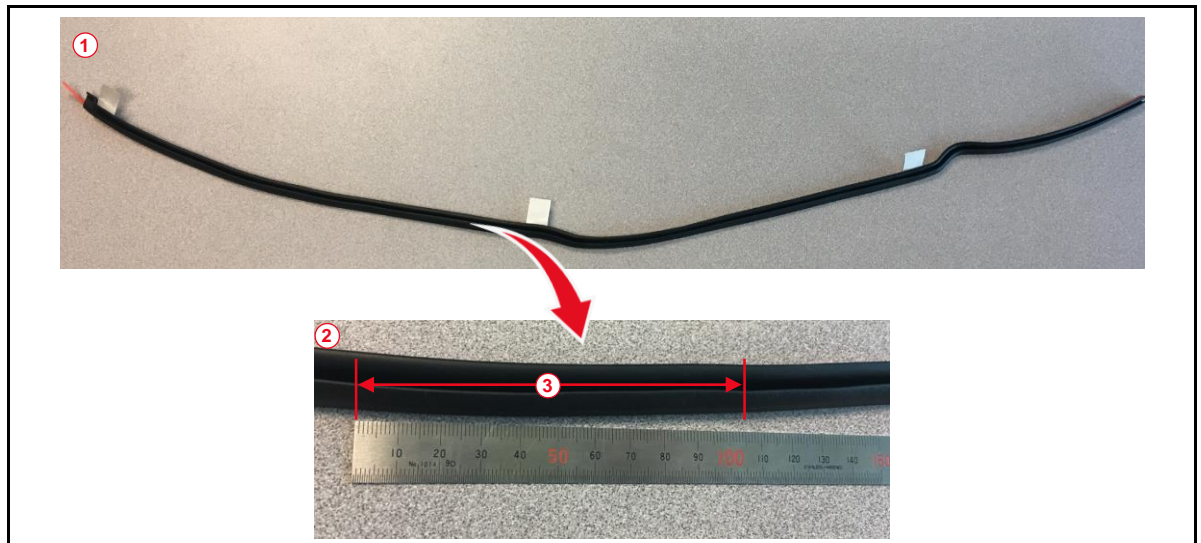

1	RR Door No. 3 Weatherstrip
2	Weatherstrip Extrusion Section

3	Cut 105 mm (4.1 in.)
----------	----------------------

Snow Intrusion Preventing Front Door From Fully Opening

Repair Procedure (continued)

6. If the vehicle has been exposed to a cold environment for an extended period, use a heat gun to bring the A-pillar section to room temperature (between 60°F – 100°F).

7. Clean the A-pillar section using isopropyl alcohol and allow it to dry for one minute.

Figure 3.

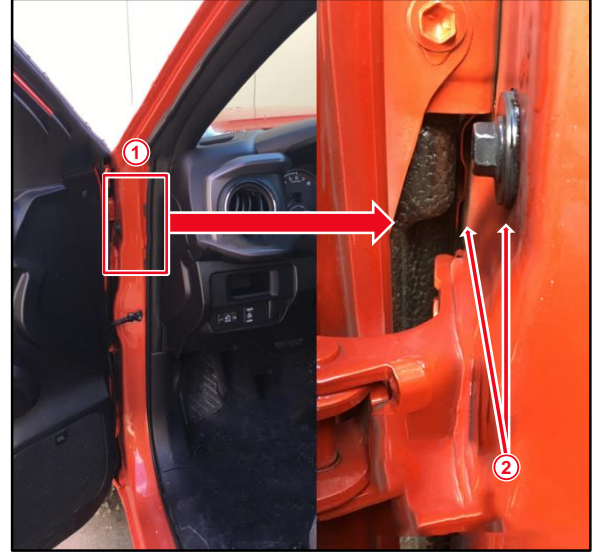

1	A-pillar Section
2	Area That Must Reach Room Temperature

Snow Intrusion Preventing Front Door From Fully Opening

Repair Procedure (continued)

8. Install the weatherstrip extrusion from the door opening side.
 - A. Pull back 1/3 of the tape for temporary placement. Then starting at the front fender well, remove the rest of the tape to press the weatherstrip fully onto the body side outer panel.
 - B. Refer to the installation reference points as shown to apply the weatherstrip extrusion section.

NOTE

Figure 4 shows an example of a no-good orientation of the weatherstrip extrusion section that should look like a “u,” not an “n.” The open channel will be facing up.

Figure 4.

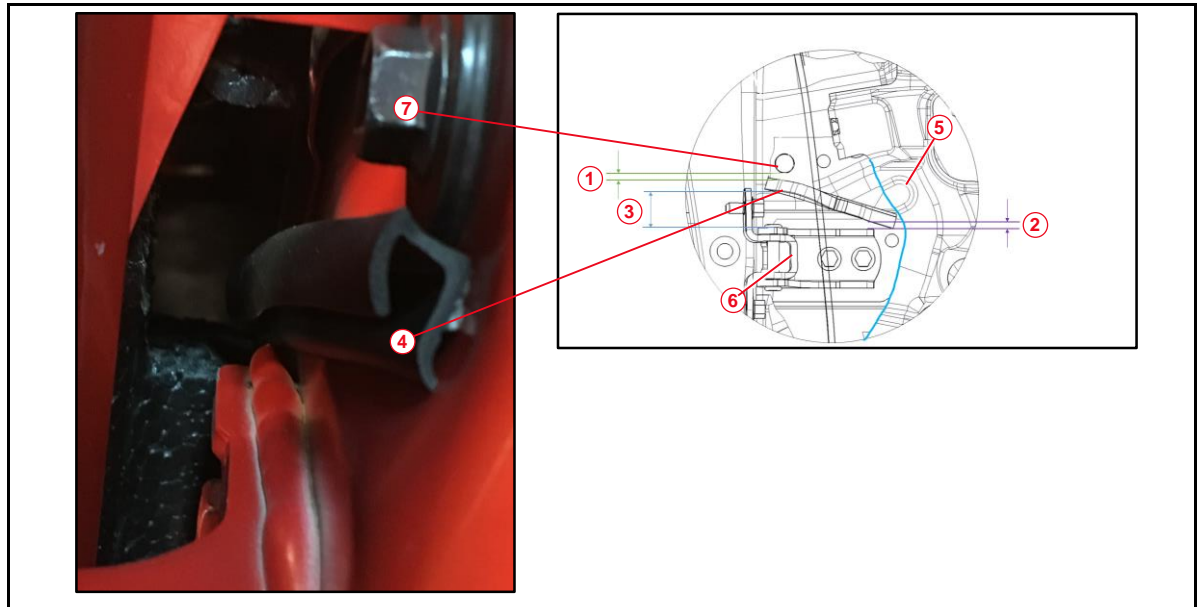

1	Relative Distance to Bolt Washer, 5 mm
2	FR Position Relative Distance to Front Door Hinge Upper, 5 mm
3	RR Position Relative Distance to Front Door Hinge Upper, 30 mm
4	Countermeasure Weatherstrip Extrusion “n” Orientation—No Good

5	Panel, Cowel Top Side
6	Front Door Hinge Upper
7	Bolt Washer

9. Apply continuous pressure to the weatherstrip extrusion to ensure proper adhesion (approximately 20 – 30 seconds).
10. Allow to fully cure and keep the vehicle between 60°F – 100°F for AT LEAST 20 minutes.

Snow Intrusion Preventing Front Door From Fully Opening

Repair Procedure (continued)

11. Remove the front fender side protector (P/N 53827-04020 for right or 53828-04020 for left) from inside the front fender well.

12. Using a hacksaw or equivalent blade, cut the material from the inboard side of the front fender protector (P/N 53827-04020 for right or 53828-04020 for left), following the front fender side protector cutout.

13. Smooth the cut surfaces using sandpaper or a handheld sanding tool.

Figure 5.

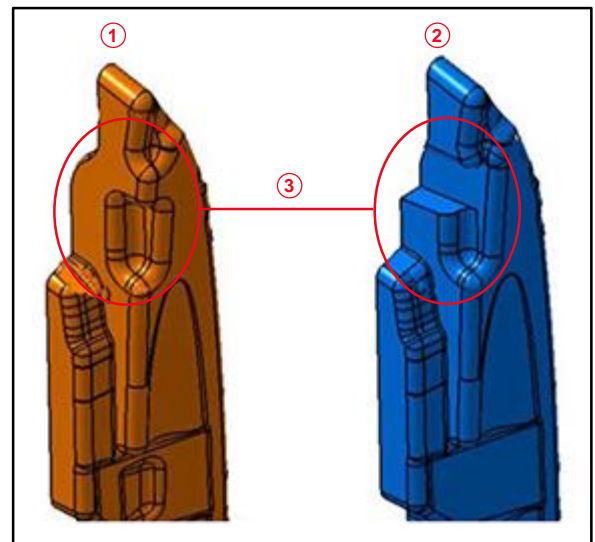

1	Before
2	After
3	Cut Surface

14. Trim the instrument panel No. 1 cushion (55355-0C050) (EPT sponge material with tape backing) to approximately 550 mm (21.6 in.) in length (original length 1,323 mm).

Snow Intrusion Preventing Front Door From Fully Opening

Repair Procedure (continued)

15. Install the EPT sponge material to the outer surface of the front fender side protector.

Start on the outboard side, wrap under the bottom face of the protector, and then end on the inboard side. (The sponge material should be one continuous piece.)

Figure 6.

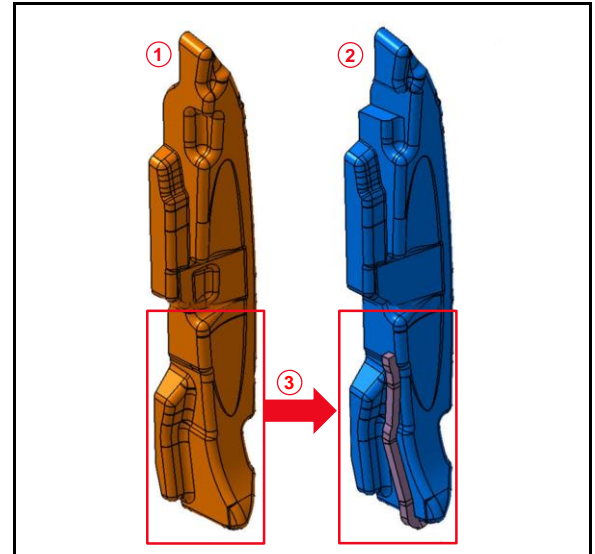

1	Old
2	New
3	EPT Sponge Attachment Location

Figure 7.

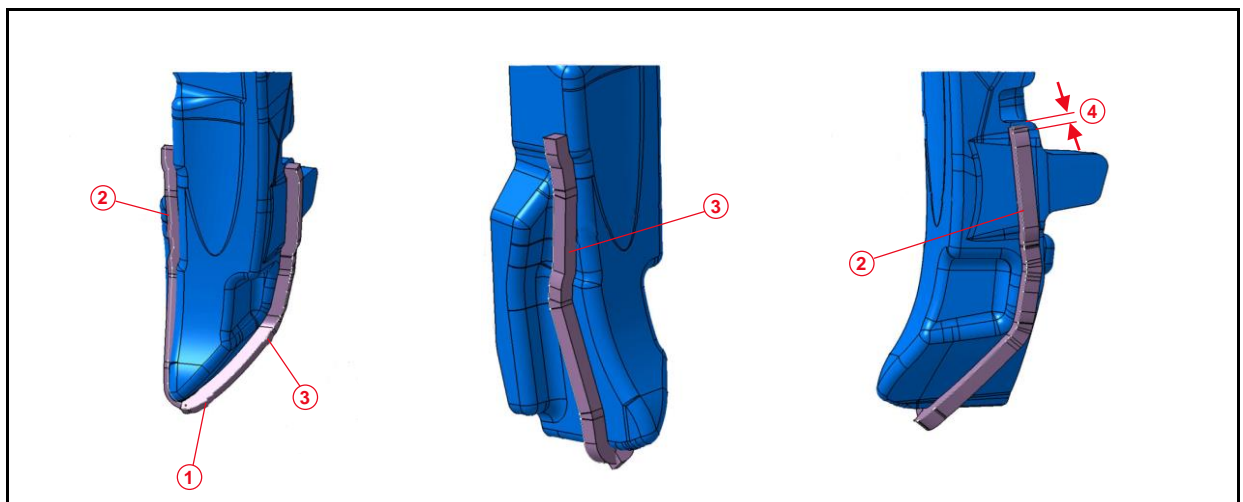

1	EPT Sponge
2	265 mm
3	285 mm

4	5 mm
---	------

Snow Intrusion Preventing Front Door From Fully Opening

Repair Procedure (continued)

16. Install the countermeasure front fender side protector. Ensure the EPT sponge has not been damaged or has fallen off the front fender side protector AFTER installation.

17. Inspect the countermeasure weatherstrip channel area. Ensure the front fender side protector has not damaged the weatherstrip channel adhesion to the panel.

18. Reinstall the following parts:
 - A. Front fender wheel opening molding (right/left).
 - B. Front fender liner (right/left). Replace the five clips closest to the door side.
 - C. Front mudguard (right/left) (if applicable).
 - D. Tire and wheel (right/left).

Figure 8.

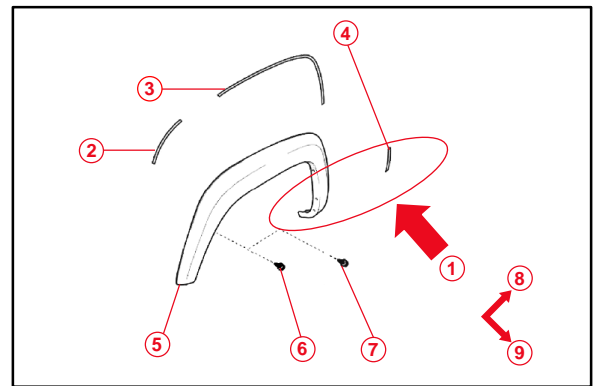

1	Peel Back Section
2	Front Wheel Opening Extension Pad
3	No. 1 Front Wheel Opening Extension Pad
4	No. 2 Front Wheel Opening Extension Pad
5	Front Fender Wheel Opening Molding
6	Bolt
7	Bolt With Mudguard
8	RR
9	Outboard

Snow Intrusion Preventing Front Door From Fully Opening

Front Fender Side Protector Cutout

Block section should be cut out 20 mm (3/4 in.) deep.

