

2023 RZ 450e Pre-Delivery Service (PDS)

Service Category General

Section Pre-Delivery Service

Market USA

Toyota Supports
ASE Certification 

Applicability

YEAR(S)	MODEL(S)	ADDITIONAL INFORMATION
2023	RZ450E	

REVISION NOTICE

March 21, 2023 Rev1:

- The Power Back Door Initialization section has been updated.
- Any previous printed versions of this bulletin should be discarded.

Introduction

This bulletin contains the vehicle specific pre-delivery services for 2023 model year RZ 450e vehicles. Additionally, refer to the applicable Pre-Delivery Service (PDS) Check Sheet for services to be performed.

Warranty Information

OP CODE	DESCRIPTION	TIME	OFF	T1	T2
N/A	Not Applicable to Warranty	–	–	–	–

2023 RZ 450e Pre-Delivery Service (PDS)

Required Tools & Equipment

REQUIRED EQUIPMENT	SUPPLIER	PART NUMBER	QTY
Techstream ADVi*	ADE	TSADVUNIT	1
Techstream 2.0		TS2UNIT	
Techstream Lite		TSLITEPDLR01	
Techstream Lite (Green Cable)		TSLP2DLR01	

*Essential SST.

NOTE

- Only ONE of the Techstream units listed above is required.
- GTS+ software version 2022.04.004.02 or later is required.
- Additional Techstream units may be ordered by calling Approved Dealer Equipment (ADE) at 1-800-368-6787.

Procedures

- [D/C Cut Fuse \(30A\) Installation](#)..... 3
- [Head Unit System Reset](#)..... 4
- [Seating Position Control ECU Initialization](#)..... 4
- [Power Back Door Initialization](#)..... 4
- [Customize ACC Function](#)..... 4
- [Enable Hybrid Battery Thermal Keep Control Mode](#)..... 5
 - [Confirm Hybrid Battery Thermal Keep Control Mode State](#)..... 5
 - [Set Hybrid Battery Thermal Keep Control Mode](#)..... 6
- [Front and Rear Emergency Towing Eyelet Removal and Hole Cover Installation](#)..... 7
- [Front License Plate and Mounting Bracket Installation*](#)..... 9
- [Installation of Rubber Body Plugs](#)..... 11
- [Set Hybrid Radio Feature to OFF](#)..... 12
- [Navigation — Set Date & Time by GPS](#)..... 12
- [Tire Pressure Warning System \(TPWS\) Initialization](#)..... 12
- [Set Remote Park Feature to OFF*](#)..... 13

*If Applicable

2023 RZ 450e Pre-Delivery Service (PDS)

D/C Cut Fuse (30A) Installation

To minimize battery discharge during transportation and storage, the D/C cut fuse (30A) has been removed at the assembly plant and temporarily stored in the blank space of the relay block in the engine compartment. During PDS, reinstall the D/C cut fuse (30A) to its original location and confirm ALL related Diagnostic Trouble Codes (DTCs) are cleared.

Remove the D/C cut fuse (30A) from the blank space of the relay block in the engine compartment and install the D/C cut fuse (30A) in the relay block as shown.

Figure 1.

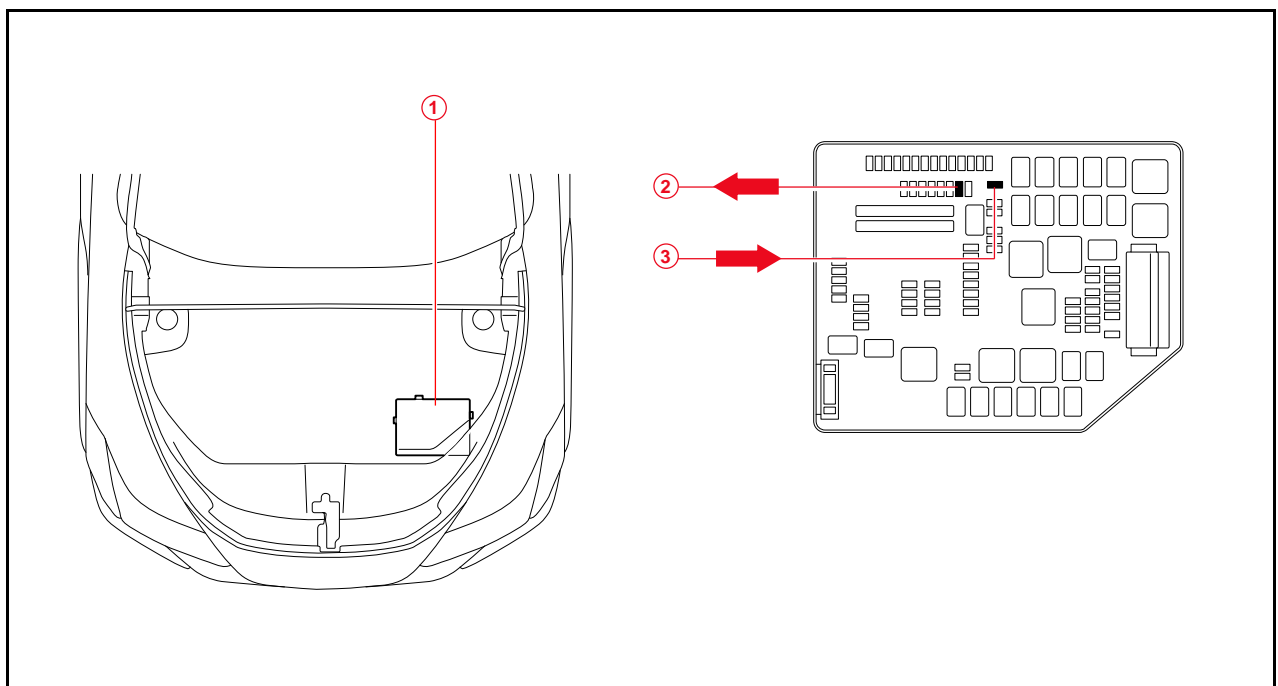

1	Relay Block
2	Remove D/C Cut Fuse (30A)

3	Install D/C Cut Fuse (30A) (Original Location)
----------	---

NOTE

With the DC cut fuse (30A) removed, the diagnostic trouble code (DTC) is detected when the ignition is turned on during transportation. Clear all DTCs using the GTS+ AFTER checking that there are no malfunctions on the vehicle.

2023 RZ 450e Pre-Delivery Service (PDS)

Head Unit System Reset

Before selling a Toyota vehicle, please confirm that the welcome screen with language options appears on the head unit display when ignition is switched to the ON position. There may be instances where the welcome screen with language options may not properly appear on the head unit display.

If the welcome screen showing language options is not displayed, complete the following steps:

1. Select the Settings option (gear icon).
2. Scroll down and select the Info & Security option.
3. The System Reset dialogue box will appear. Select Reset to confirm the resetting of system.
4. Confirm that the welcome screen with language options is now displayed.

Seating Position Control ECU Initialization

Refer to the applicable Repair Manual for the seating position control ECU [initialization procedure](#) (procedure 3).

Power Back Door Initialization

Refer to the applicable Repair Manual for the power back door [initialization procedure](#).

Customize ACC Function

The pre-startup function detects when a user enters the vehicle and energizes the audio head unit (+BA) so that the multimedia system can quickly be used. This function is not enabled at the factory to reduce parasitic current draw in transit and storage. To enable this function, it is necessary to set the ACC customization function in the navigation display to OFF within the GTS+ software.

1. Turn the engine switch (power switch) to the ON position (ON mode).
2. Enter the following menus: *Settings – Vehicle Customization – Utility – ACC Customize*.
3. Change the setting to OFF (toggle at left with gray background).

2023 RZ 450e Pre-Delivery Service (PDS)

Enable Hybrid Battery Thermal Keep Control Mode

HV/BEV battery may be frozen in extremely cold areas. As a result, the HV/BEV battery may become excessively weak, and the system may NOT be able to be started. By enabling HV/BEV Battery Thermal Keep Control Mode, it is possible to warm the HV/BEV battery and maintain its current temperature in order to prevent it from becoming excessively weak.

When this mode is set to ON, the timer charging settings are canceled at temperatures of 14°F (-10°C) or lower. Charging will begin immediately when the charging cable is connected to the vehicle.

Table 1. HV/BEV Battery Thermal Keep Control Mode

PURPOSE	CONDITION	OPERATION
Prevent HV/BEV battery from freezing.	<ul style="list-style-type: none"> Ambient temperature is 14°F (-10°C) or lower. Charging cable is connected to vehicle. 	<ul style="list-style-type: none"> Begins to warm the HV/BEV battery to maintain its current temperature when the ambient temperature drops to 14°F (-10°C) or lower when the charging cable is connected to the vehicle. To prevent the HV/BEV battery from freezing when a charging start time is set, when the HV/BEV Battery Thermal Keep Mode is enabled, the charging timer will be disabled, and charging will begin immediately when the charging cable is connected to the vehicle.

To enable HV/BEV Battery Thermal Keep Control Mode, it is necessary to use GTS+ during PDS at the dealership.

Confirm Hybrid Battery Thermal Keep Control Mode State

1. Connect the Techstream to the DLC3.
2. Turn the power switch IG-ON.
3. Read the Data List on GTS+ software by entering the following menus: *Powertrain – HV Battery – Data List – Hybrid Battery Thermal Keep Control Mode Status.*
4. Check the results by referring to the following table:

Table 2.

TESTER DISPLAY	MEASUREMENT ITEM	RANGE	NORMAL CONDITION
Hybrid Battery Thermal Keep Control Mode Status	Hybrid Battery Thermal Keep Control Mode State	ON or OFF	ON: Enabled OFF: Disabled

2023 RZ 450e Pre-Delivery Service (PDS)

Enable Hybrid Battery Thermal Keep Control Mode (continued)

Set Hybrid Battery Thermal Keep Control Mode

1. Connect the Techstream to the DLC3.
2. Turn the power switch to IG-ON.
3. Turn the Techstream ON.
4. Enter the following menus: *Powertrain – HV Battery – Utility – Hybrid Battery Thermal Keep Control Mode.*

Figure 2.

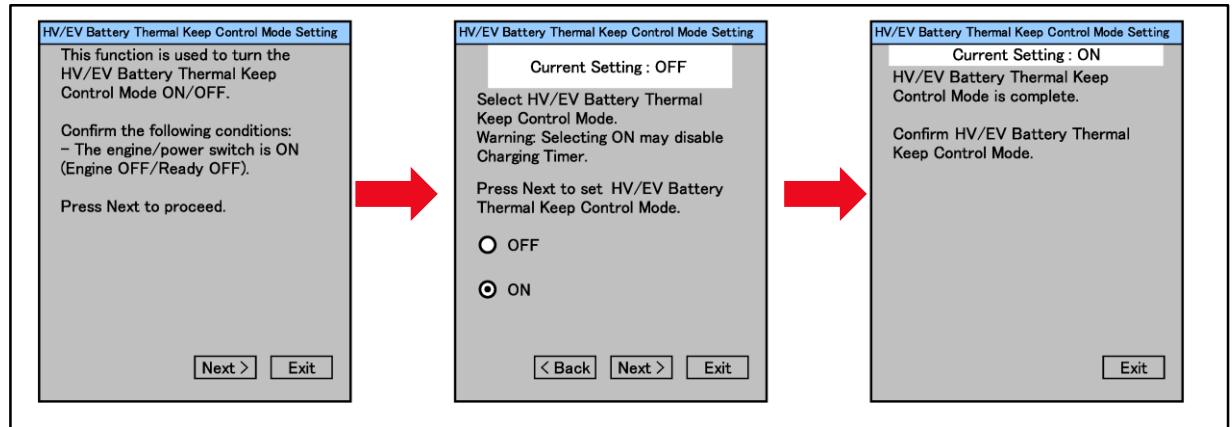

5. Confirm the following message is displayed:
"This function is used to turn the Hybrid Battery Thermal Keep Control Mode ON / OFF."
6. Confirm that the conditions displayed on the screen are met, and then press Next.

NOTE

The power switch is ON (Ready OFF).

7. Confirm the following message is displayed:
"Select Hybrid Battery Thermal Keep Control Mode."
8. Select ON and press Next.

NOTICE

Selecting ON may disable the charging timer.

9. Confirm the following message is displayed:
"Hybrid Battery Thermal Keep Control Mode is complete."

2023 RZ 450e Pre-Delivery Service (PDS)

Front and Rear Emergency Towing Eyelet Removal and Hole Cover Installation

1. Remove the front and rear emergency towing eyelets from the front and rear bumpers by turning them counterclockwise.

HINT

If it is difficult to loosen the emergency towing eyelets, use a steel bar.

Figure 3.

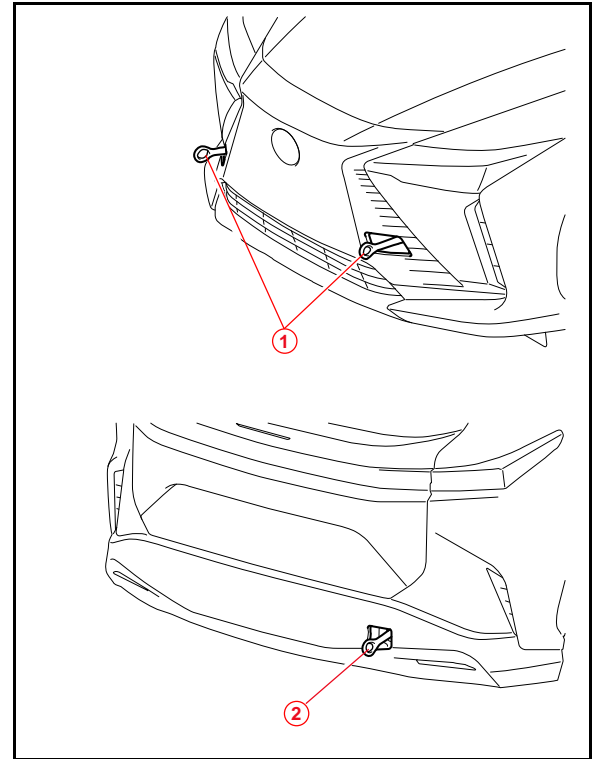

1	Front Emergency Towing Eyelets
2	Rear Emergency Towing Eyelet

2. Place one of the removed emergency towing eyelets into the luggage tray in the luggage compartment.

HINT

Dispose of the other removed emergency towing eyelets.

Figure 4.

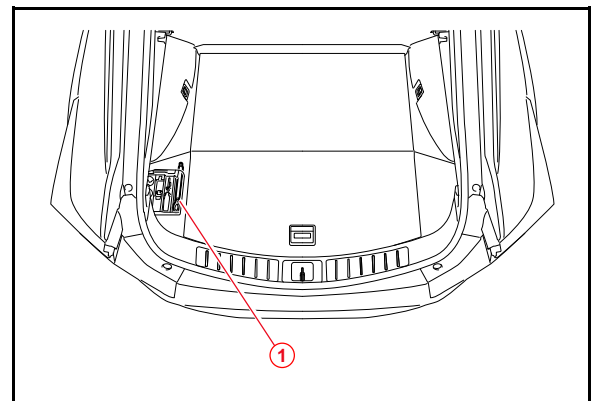

1	Emergency Towing Eyelet
----------	--------------------------------

2023 RZ 450e Pre-Delivery Service (PDS)

Front and Rear Emergency Towing Eyelet Removal and Hole Cover Installation (continued)

3. Install the front and rear emergency towing eyelet hole covers, which are stored in the glove compartment, onto the front and rear bumpers.
 - A. Insert the arrow-shaped part of the emergency towing eyelet hole cover "A" into the eyelet hole "B" as shown.
 - B. Install the emergency towing eyelet hole cover to the hole of the bumper.

HINT

Make sure the front emergency eyelet towing cover is installed in front, and the rear emergency eyelet towing cover is installed in the rear.

Figure 5.

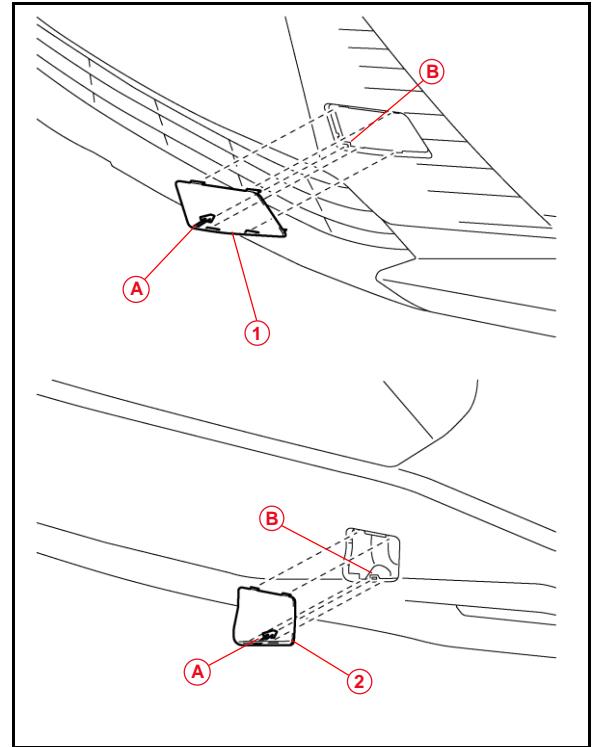

A	Arrow-shaped Part
B	Eyelet Hole
1	Front Emergency Towing Eyelet Hole Cover
2	Rear Emergency Towing Eyelet Hole Cover

2023 RZ 450e Pre-Delivery Service (PDS)

Front License Plate and Mounting Bracket Installation

The front license plate bracket and two self-tapping screws are stored in the vehicle. Follow this procedure to install the front license plate bracket and front license plate in states where it is required by law

1. Align holes "A" of the mounting bracket with the dimples on the front bumper cover. Mark the location of holes "B" on the bumper cover.

NOTE

- Holes "A" are used for installation of the mounting bracket to the bumper cover.
- Holes "B" are used for the installation of the front license plate to the mounting bracket.

2. Drill two relief holes with a diameter of 11 mm (0.43 in.) at the hole "B" marks on the front bumper cover to prevent the license plate retaining bolt end from contacting the cover.

NOTICE

- Do NOT pre-drill holes into the dimples.
- Do NOT overtighten the self-tapping screws.

Figure 6.

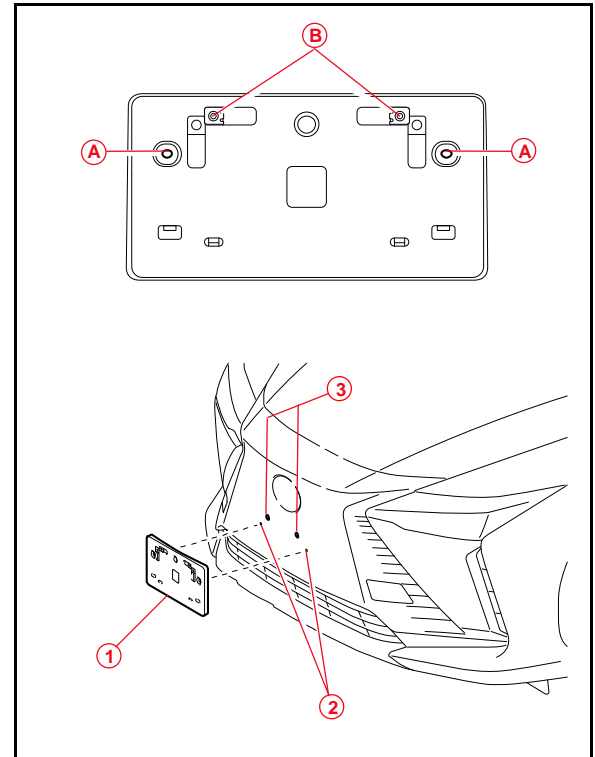

1	Mounting Bracket
2	Dimples
3	Mark and Drill Holes

3. Install the mounting bracket to the front bumper cover by attaching the two self-tapping screws.

2023 RZ 450e Pre-Delivery Service (PDS)

Front License Plate and Mounting Bracket Installation (continued)

- Install the front license plate onto the mounting bracket at holes "B" using two noncorroding bolts with the following dimensions:

Nominal Length: 15.0 mm (0.59 in.)

Diameter: 6.0 mm (0.24 in.)

Figure 7.

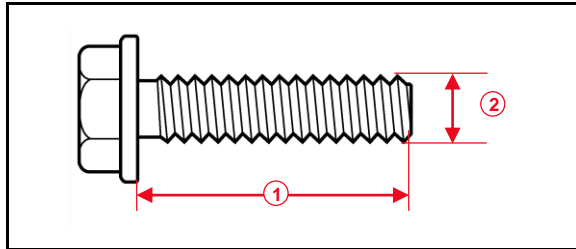

1	Nominal Length
2	Diameter

Figure 8.

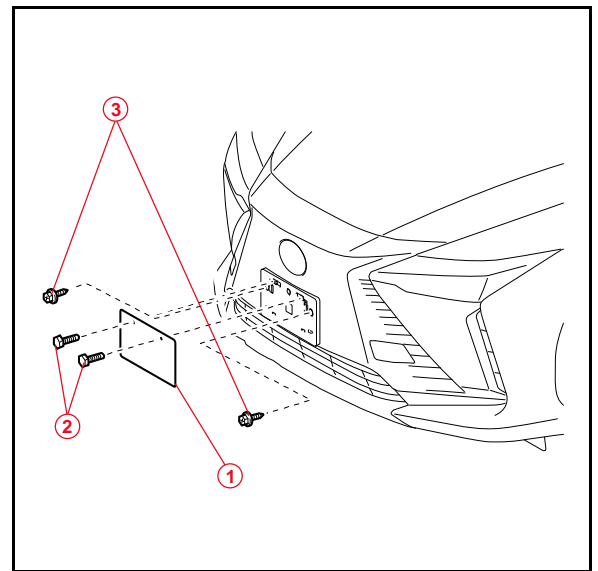

1	Front License Plate
2	Bolts
3	Self-tapping Screws

2023 RZ 450e Pre-Delivery Service (PDS)

Installation of Rubber Body Plugs

1. Confirm the number of plugs in the glove box. If two plugs are present, perform substep 2A ONLY. If four plugs are present, perform substep 2A AND substep 2B.
2. Install plugs according to the following instructions by confirming the number of plugs in the glove box.
 - A. Install two plugs in the rear side member hole or rocker inner hole.
 - B. Install two plugs in the torque box hole or rocker inner hole.

Figure 9.

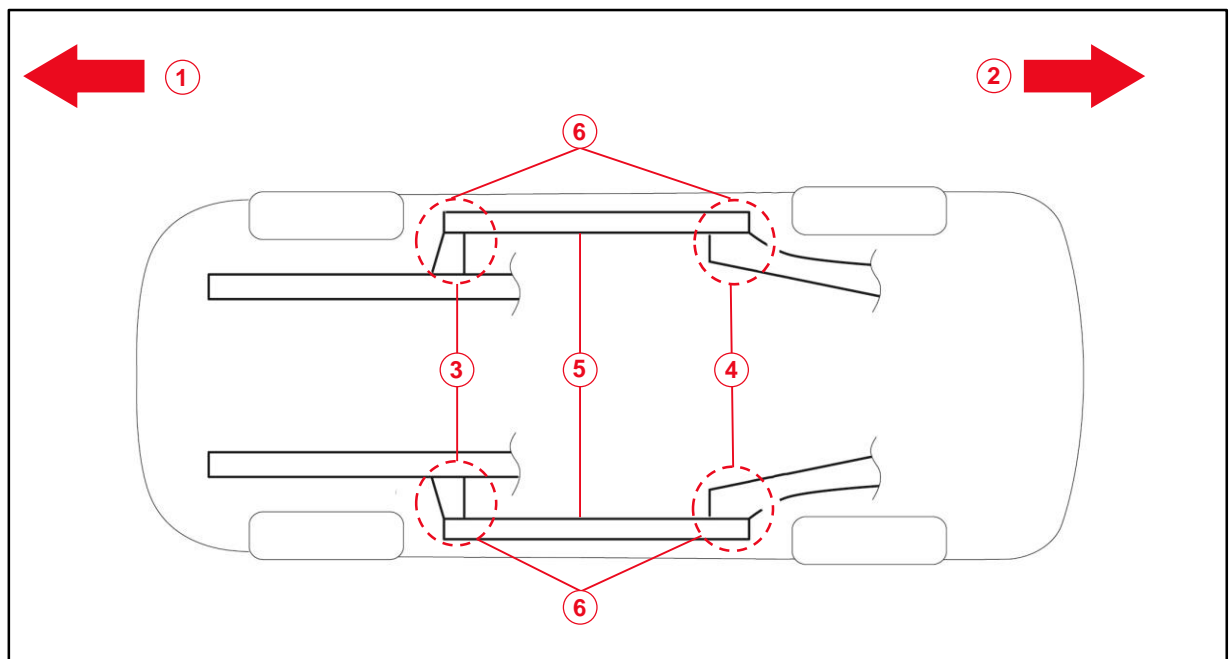

1	Front Side
2	Rear Side
3	Torque Box Hole or Rocker Inner Hole
4	Rear Side Member Hole or Rocker Inner Hole
5	Rocker Inner
6	Install Plug Here (if Applicable)

NOTICE

- The installation of these plugs is required to prevent rust.
- These plugs are stored in the glove box.
- The number of plugs may vary according to production locations in the same vehicle model.

2023 RZ 450e Pre-Delivery Service (PDS)

Set Hybrid Radio Feature to OFF

Without a Wi-Fi subscription, the customer will receive a “Subscription Required” pop-up while in weak broadcast radio signal areas. This pop-up notification may cause confusion to the customer. Therefore, it is necessary to toggle the Hybrid Radio feature to the OFF position.

1. Turn the engine switch (power switch) to ON position (ON mode).
2. Navigate the following menus in the head unit: *Settings – Sound and Media – Radio – Hybrid Radio*.
3. Ensure the Hybrid Radio function is set to the OFF position.

NOTE

The “Enable hybrid radio” feature is factory preset to the ON position.

Navigation — Set Date & Time by GPS

Before selling a Lexus vehicle, we are asking that dealers please confirm that they have turned the “Set time by GPS” functionality on in each vehicle. Therefore, it is necessary to turn the Set Time by GPS setting to the ON position.

1. Turn the engine switch (power switch) to ON position (ON mode).
2. Navigate the following menus in the head unit: *Settings – General – Date & Time – Set date & time by GPS*.
3. Ensure the Set date & time by GPS function is set to the ON position.

Tire Pressure Warning System (TPWS) Initialization

Refer to the applicable Repair Manual for the TPWS [initialization procedure](#). Note the spare tire does NOT have a TPWS sensor.

NOTE

To adjust the tire pressure correctly when the outside temperature is significantly colder than shop temperature, perform a Health Check using Techstream and select the compensation tire pressure checkbox. Compensation pressures will display on the Health Check results screen. Adjust the tire pressure when the tires are cold.

2023 RZ 450e Pre-Delivery Service (PDS)

Set Remote Park Feature to OFF

Some RZ models may be equipped with Advanced Park. The Advanced Park system assists in safely and smoothly parking in a target parking space by displaying the blind spots around the vehicle and the parking spot through a bird's eye view, delivering operation guidance through displays and buzzer operation, and changing the shift position, operating the steering wheel, accelerator pedal, and brake pedal. The Lexus smartphone app Remote Park feature will not be available for RZ vehicles equipped with Advanced Park. To minimize guest dissatisfaction, follow the procedure below to disable the Remote Park feature on the vehicle:

1. Start the vehicle or set to ACC ON.
2. Press the Advanced Park switch.
3. Press the Advanced Park settings button.
4. Toggle the Remote Park indicator to OFF (blue is ON, gray is OFF).
5. Exit by pressing "X" at the top left of the screen.
6. Press the Advanced Park button.
7. Confirm the Remote Park button is no longer present.

NOTE

The Remote Park feature is factory preset to the ON position.

Figure 10. Advanced Park Switch

